



## A6283

## LINEAR INTEGRATED CIRCUIT

### 4.6W DUAL AUDIO POWER AMPLIFIER

#### DESCRIPTION

UTC **A6283** is an audio power IC with built-in two channels developed for portable radio cassette tape recorder.

Because of the parts reduction and sip (Single In line Package), space merit is remarkable.

Thermal shut down protection circuit is built in.

#### FEATURES

- \* High Power
- \*  $P_{OUT} = 2.5W/CH$  (Typ.)  
: ( $V_{CC} = 9V, R_L = 4\Omega, f = 1kHz, THD = 10\%$ )
- $P_{OUT} = 4.6W/CH$  (Typ.)  
: ( $V_{CC} = 12V, R_L = 4\Omega, f = 1kHz, THD = 10\%$ )
- \* Low popping noise at power ON
- \* Small Quiescent Current  
:  $I_Q = 19mA$  (Typ.), ( $V_{CC} = 9V, V_{IN} = 0$ )
- \* Soft Clip
- \* Built-in thermal shut down protection circuit
- \* Best for supply voltage 9V, 12V
- \* Operation supply voltage range:  $V_{CC} = 6\sim 15V$

[www.DataSheet4U.com](http://www.DataSheet4U.com)

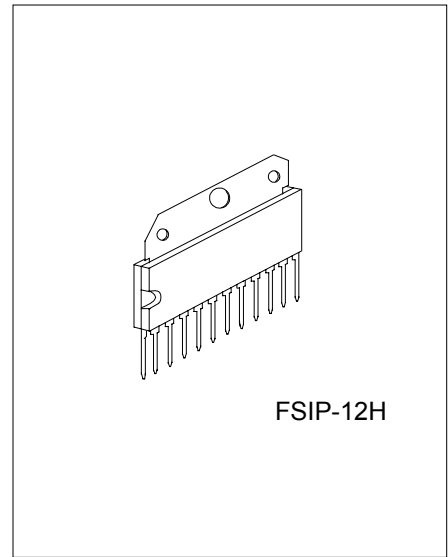

FSIP-12H

\*Pb-free plating product number: A6283L

#### ORDERING INFORMATION

Order Number		Package	Packing
Normal	Lead Free Plating		
A6283-F12-T	A6283L-F12-T	FSIP-12H	Tube

<p>A6283L-F12-T</p> <p>(1)Packing Type (2)Package Type (3)Lead Plating</p>	<p>(1) T: Tube (2) F12: FSIP-12H (3) L: Lead Free Plating, Blank: Pb/Sn</p>
--	---

## ■ PIN DESCRIPTION (TOP VIEW)

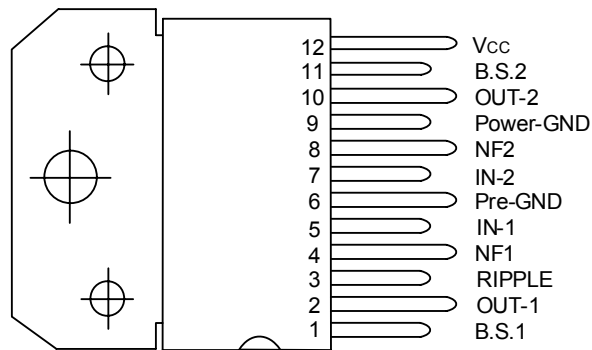

FSIP-12H

### ■ ABSOLUTE MAXIMUM RATINGS (Ta = 25°C)

PARAMETER	SYMBOL	RATINGS	UNIT
Supply Voltage	V <sub>CC</sub>	20	V
Output Current (Peak/CH)	I <sub>O(PEAK)</sub>	2.5	A
Power Dissipation	P <sub>D</sub>	12.5	W
Junction Temperature	T <sub>J</sub>	+125	°C
Operating Temperature	T <sub>OPR</sub>	-20~ +75	°C
Storage Temperature	T <sub>STG</sub>	-55~+150	°C

Note Absolute maximum ratings are those values beyond which the device could be permanently damaged. Absolute maximum ratings are stress ratings only and functional device operation is not implied.

### ■ TYPICAL DC VOLTAGE OF EACH TERMINAL (V<sub>CC</sub> = 9V, Ta = 25°C)

TERMINAL NO.	1	2	3	4	5	6	7	8	9	10	11	12
DC VOLTAGE (V)	8.2	4.5	8.9	0.6	0.01	GND	0.01	0.6	GND	4.5	8.2	V <sub>CC</sub>

### ■ ELECTRICAL CHARACTERISTICS

(Ta = 25°C, V<sub>CC</sub> = 6V, R<sub>G</sub> = 600Ω, R<sub>L</sub> = 10kΩ, f = 1kHz, unless otherwise specified.)

PARAMETER	SYMBOL	TEST CONDITIONS	MIN	TYP	MAX	UNIT
Quiescent Current	I <sub>Q</sub>	V <sub>IN</sub> = 0		20	45	mA
Input Offset Voltage	V <sub>5</sub> , V <sub>7</sub>			20	60	mV
Output Power	P <sub>OUT(1)</sub>	THD = 10%	2.0	2.5		W
	P <sub>OUT(2)</sub>	THD = 10%, V <sub>CC</sub> = 12V		4.6		
Voltage Gain	G <sub>V(1)</sub>	R <sub>F</sub> = 82Ω, V <sub>OUT</sub> = 0dBm	43	45	47	dB
	G <sub>V(2)</sub>	R <sub>F</sub> = 0, V <sub>OUT</sub> = 0dBm		56		
Output Noise Voltage	eN	R <sub>G</sub> = 10kΩ, BW = 20Hz~20kHz		0.3	1.0	mV <sub>RMS</sub>
Input Resistance	R <sub>IN</sub>			30		kΩ
Ripple Rejection Ratio	RR	R <sub>G</sub> = 600Ω, V <sub>RIP</sub> = 0.2V <sub>RMS</sub> f <sub>RIP</sub> = 100Hz,		50		dB
Cross Talk	C.T	R <sub>G</sub> = 600Ω, Amp1 ← → 2 V <sub>OUT</sub> = 0dBm, f <sub>RIP</sub> = 1kHz,		60		dB
Total Harmonic Distortion	THD	P <sub>OUT</sub> = 1W/CH		0.2	1.0	%

## ■ TEST CIRCUIT & BLOCK DIAGRAM

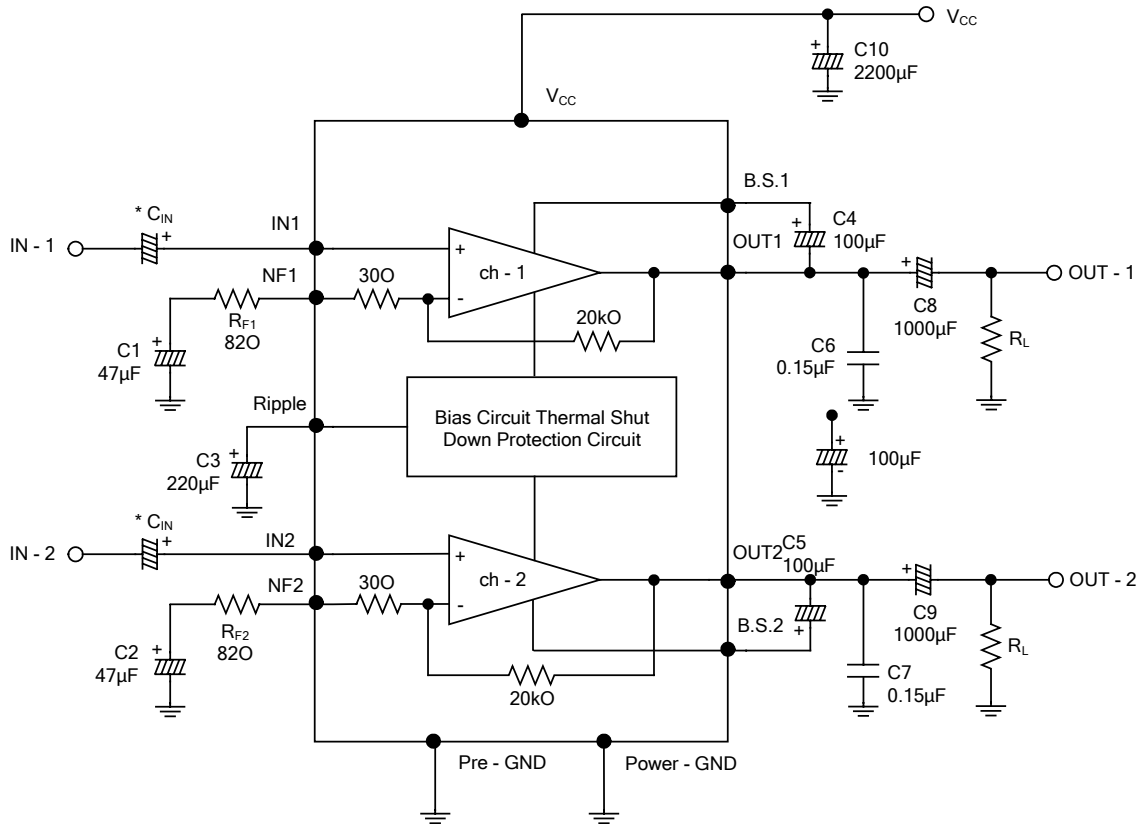

\* This IC can be used without coupling capacitor ( $C_{IN}$ ). If volume slide noise occurred by input offset voltage is undesirable, it needs to use the capacitor ( $C_{IN}$ ).

■ **APPLICATION INFORMATION AND APPLICATION METHOD**

1. ADJUSTMENT OF VOLTAGE GAIN

The voltage gain  $G_V$  is obtained as follows by  $R_1$ ,  $R_2$  and  $R_F$  in Fig.1.

$$G_V = 20 \log \frac{R_F + R_1 + R_2}{R_F + R_1}$$

When  $R_F = 0$        $G_V = 56\text{dB}$  (Typ.)

When  $R_F = 82\Omega$      $G_V = 45\text{dB}$  (Typ.)

By increasing  $R_F$ , reduction of  $G_V$  is possible, However, since the feedback increase is liable to produce oscillation, it is recommended to use this at 40dB or over.

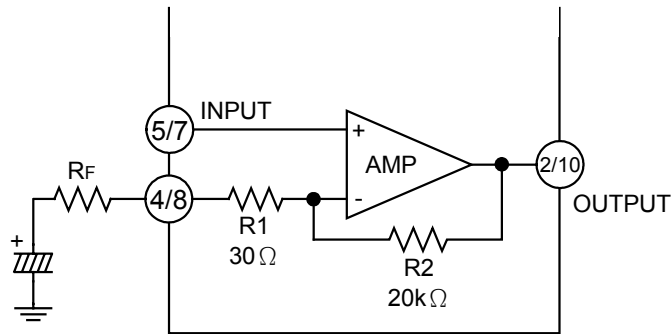

Fig.1.

2. THERMAL SHUT-DOWN CIRCUIT

The thermal shut-down circuit is built in for the purpose of preventing the destruction of IC due to the abnormal temperature rise when the heat radiation is insufficient.

## ■ APPLICATION INFORMATION AND APPLICATION METHOD (Cont.)

### 3. INPUT STAGE

The input circuit of this IC is as shown in Fig.2.

PNP TR: Q1 is provided in the input circuit so as to make its usage possible without the input coupling capacitor. However, at pins ⑤ and ⑦, max 60mV offset voltage is produced.

Application after checking volume slide noise is recommended.

For cutting the volume slide noise, inset the input capacitor:  $C_{IN}$  in series to interrupt the DC component.

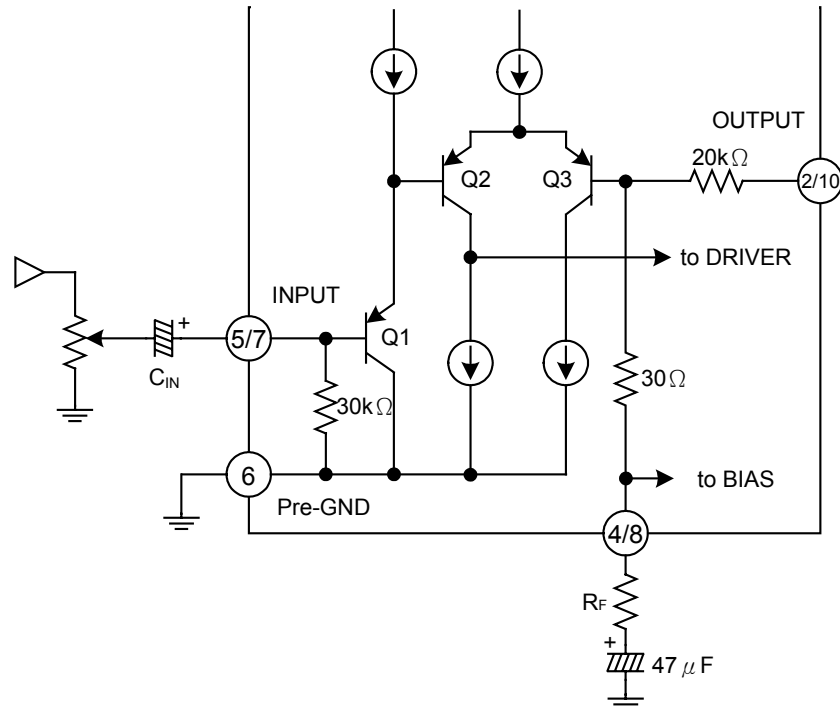

Fig.2.

### 4. OSCILLATION PERVENTIVE MEASURES

For oscillation preventive capacitor C6 and C7 between the output terminal and GND, it is recommended to use polyester film capacitor having good characteristics for temperature and for high frequency.

Since the characteristics of the capacitor is liable to be influenced by the temperature, use this capacitor after the temperature test to check the oscillation allowance. In addition, as the position of the electrolytic capacitor has a remarkable influence on the oscillation, connect C10 to  $V_{CC}$  at the nearest possible position from power GND.

At using this application with the voltage gain reduced, oscillation is liable to be produced. Apply the capacitor after checking enough for its capacity, type and mounting position.

### 5. INPUT VOLTAGE

When the excessive signal is input, turning-up is produced in the clip waveform. The turning-up point is  $V_{IN} = 300\text{mV}_{RMS}$  (Typ.):  $V_{CC} = 9\text{V}$ ,  $R_L = 4\Omega$ ,  $f = 1\text{kHz}$ : Enough care must be taken for this phenomenon.

■ TYPICAL CHARACTERISTICS

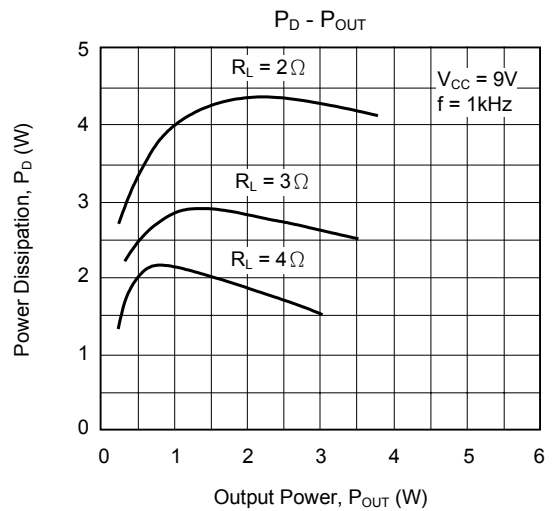
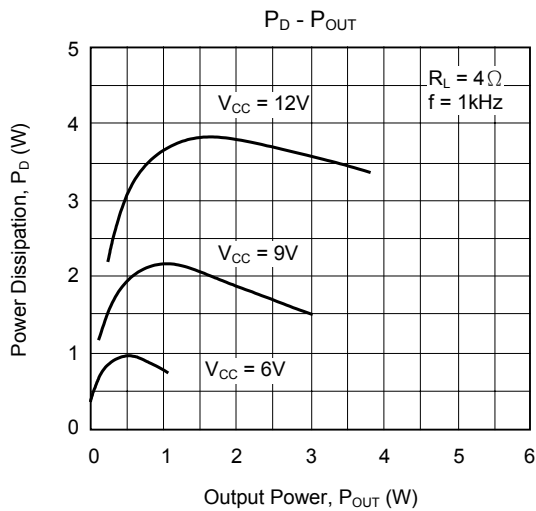
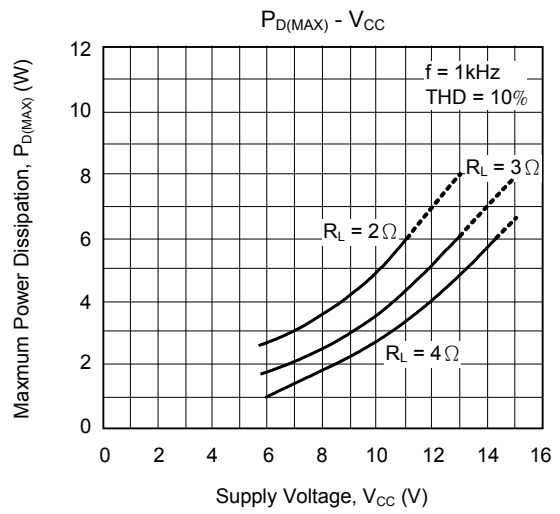
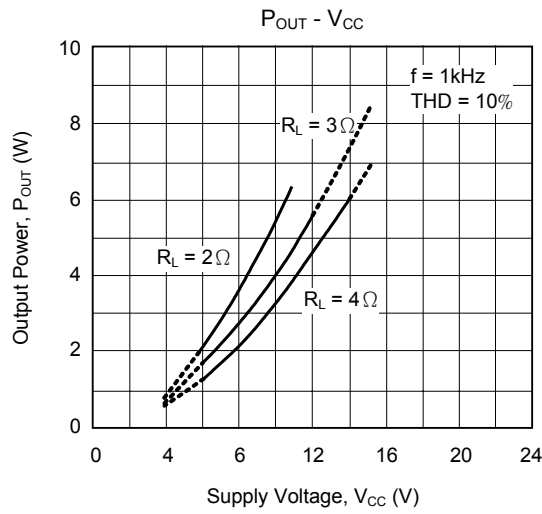

UTC assumes no responsibility for equipment failures that result from using products at values that exceed, even momentarily, rated values (such as maximum ratings, operating condition ranges, or other parameters) listed in products specifications of any and all UTC products described or contained herein. UTC products are not designed for use in life support appliances, devices or systems where malfunction of these products can be reasonably expected to result in personal injury. Reproduction in whole or in part is prohibited without the prior written consent of the copyright owner. The information presented in this document does not form part of any quotation or contract, is believed to be accurate and reliable and may be changed without notice.