



DESCRIPTION

The A6301 series are highly precise, low power consumption, positive voltage regulators manufactured using CMOS and laser trimming technologies. The series provides large currents with a significantly small dropout voltage. The A6301 consists of a current limiter circuit, a driver transistor, a precision reference voltage and an error amplifier. Output voltage is selectable in 0.1V steps between 1.3V ~ 6.0V.

The A6301 is available in SOT-23 and SOT-89-3 packages.

ORDERING INFORMATION

Package Type	Part Number	
SOT-23	E3	A6301E3R-XX
		A6301E3VR-XX
SOT-89-3	K3	A6301K3R-XX
		A6301K3VR-XX
Note	XX: Output Voltage V: Halogen free Package R: Tape & Reel	
AiT provides all RoHS products Suffix " V " means Halogen free Package		

FEATURES

- Output Voltage Range 1.2V to 6.0V (selectable in 100mV steps)
- Highly Accurate $\pm 2\%$
- Dropout Voltage 160mV @ 100mA (3.0V type)
- Low Power Consumption 4.0 μ A (TYP.)
- Maximum Output Current 300mA ($V_{IN} \geq V_{OUT} + 1V$)
- Internal protector current limiter and short protector
- Maximum Operating voltage 10V
- Available in SOT-23 and SOT-89-3 Packages

APPLICATION

- Mobile phones
- Cordless phones
- Cameras, video recorders
- Portable games
- Portable AV equipment
- Reference voltage
- Battery powered equipment

TYPICAL APPLICATION

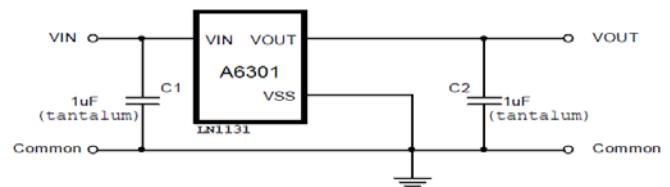

Caution: The above connection diagram and constant will not guarantee successful operation. Perform thorough evaluation using the actual application to set the constant.



PIN DESCRIPTION

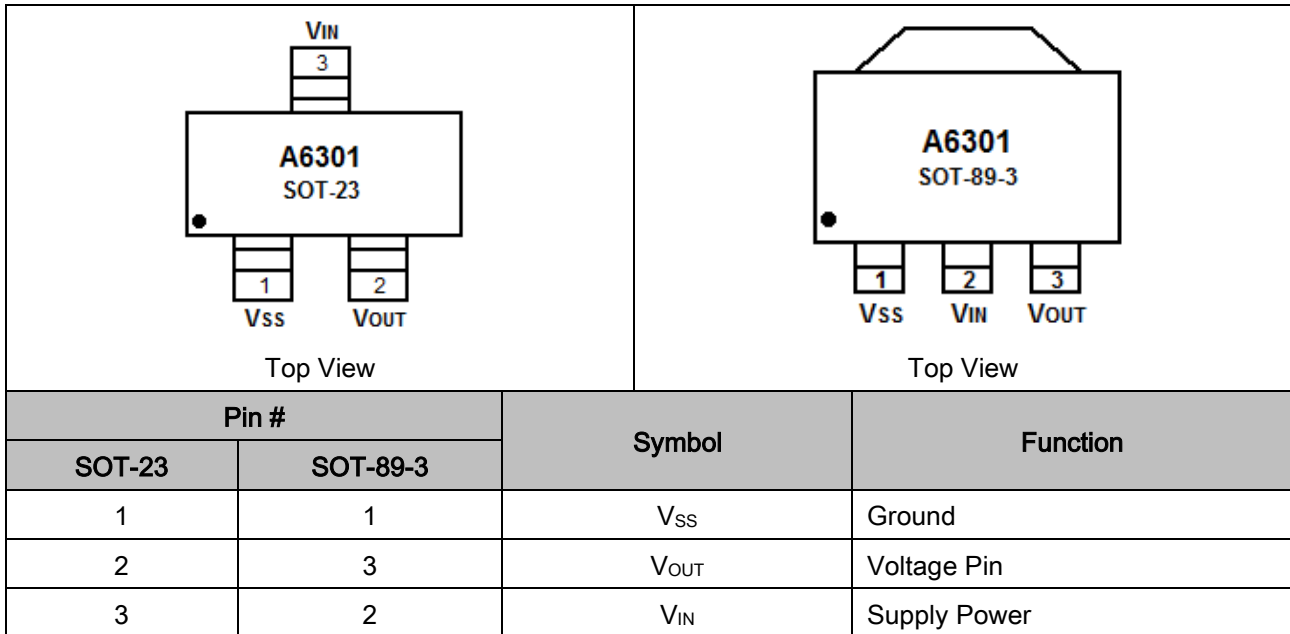

ABSOLUTE MAXIMUM RATINGS

V _{IN} , Input Voltage	V _{SS} -0.3V ~ V _{SS} +10V	
V _{OUT} , Output Current	V _{SS} -0.3V ~ V _{IN} +0.3V	
P _D , Power Dissipation	SOT-23	250mW
	SOT-89-3	500mW
T _{OPR} , Operating Ambient Temperature	-40°C ~ +85°C	
T _{STG} , Storage Temperature	-40°C ~ +125°C	

Stress beyond above listed "Absolute Maximum Ratings" may lead permanent damage to the device. These are stress ratings only and operations of the device at these or any other conditions beyond those indicated in the operational sections of the specifications are not implied. Exposure to absolute maximum rating conditions for extended periods may affect device reliability.

THERMAL RESISTANCE

Package	θ _{JA}	θ _{JC}
SOT-23	250°C/W	130°C/W

NOTE: Thermal Resistance is specified with approximately 1 square of 1 oz copper.



ELECTRICAL CHARACTERISTICS

Parameter	Symbol	Conditions	Min.	Typ.	Max.	Unit	Circuit	
Output Voltage	$V_{OUT(E)}$	$V_{IN} = V_{OUT(S)} + 1.0V$, $I_{OUT} = 40mA$	$V_{OUT(S)} \times 0.98$	$V_{OUT(S)}$	$V_{OUT(S)} \times 1.02$	V	1	
Output Current	I_{OUT}	$V_{IN} \geq V_{OUT(S)} + 1.0V$	300	-	-	mA	1	
Dropout Voltage	V_{DROP}	$I_{OUT} = 100mA$	$2.2V \leq V_{OUT(S)} \leq 2.5V$	-	0.20	0.28	V	1
			$2.6V \leq V_{OUT(S)} \leq 3.3V$	-	0.16	0.24		
			$3.4V \leq V_{OUT(S)} \leq 5.5V$	-	0.12	0.20		
Line Regulations	$\frac{\Delta V_{OUT1}}{\Delta V_{IN} \times V_{OUT}}$	$V_{OUT(S)} + 0.5V \leq V_{IN} \leq 9V$ $I_{OUT} = 80mA$	-	0.05	0.3	%/V	1	
Input Voltage	ΔV_{OUT2}	$V_{IN} = V_{OUT(S)} + 1.0V$ $1.0mA \leq I_{OUT} \leq 80mA$	-	20	40	mV		
Output Voltage Temperature Characteristics	$\frac{\Delta V_{OUT}}{\Delta T_A \times V_{OUT}}$	$V_{IN} = V_{OUT(S)} + 1.0V$ $I_{OUT} = 10mA$ $-40^\circ C \leq T_A \leq 85^\circ C$	-	± 100	-	ppm/ °C		
Supply Current	I_{SS1}	$V_{IN} = V_{OUT(S)} + 1.0V$		4	8	μA	2	
Input Voltage	V_{IN}		1.8	-	9	V	-	
Ripple-Rejection	RR	$V_{IN} = V_{OUT(S)} + 1.0V$, $f = 1.0kHz$ $V_{RIP} = 0.5V_{rms}$, $I_{OUT} = 80mA$	-	50	-	dB	1	
Short current	I_{SHORT}	$V_{IN} = V_{OUT(S)} + 1.5V$	-	60	-	mA	1	
Current Limiter	I_{LIM}	$V_{IN} = V_{OUT(S)} + 1.5V$	-	380	-	mA	1	



TYPICAL PERFORMANCE CHARACTERISTICS

3.0V output

1. Output Voltage vs. Output Current

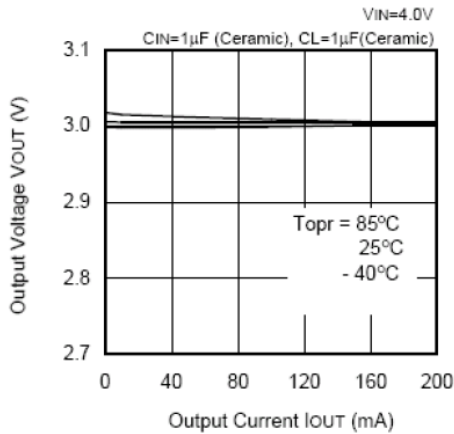

2. Output Voltage vs. Input Voltage

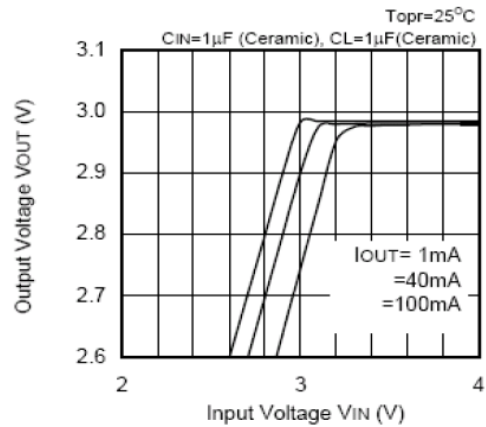

3. Dropout Voltage vs. Output Current

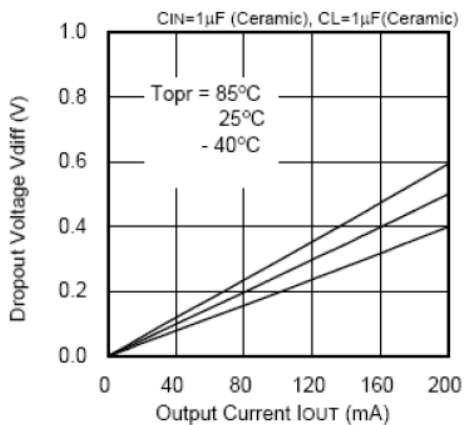

4. Dropout Voltage vs. Output Voltage

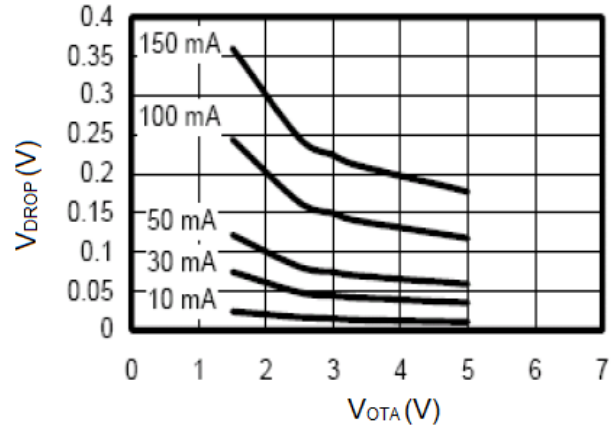

5. Output Voltage vs. Ambient Temperature

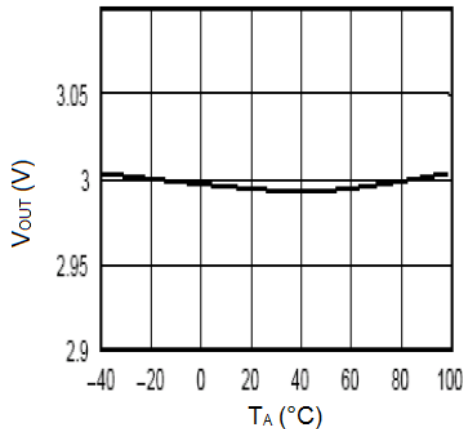

6. Ripple Rejection Rate

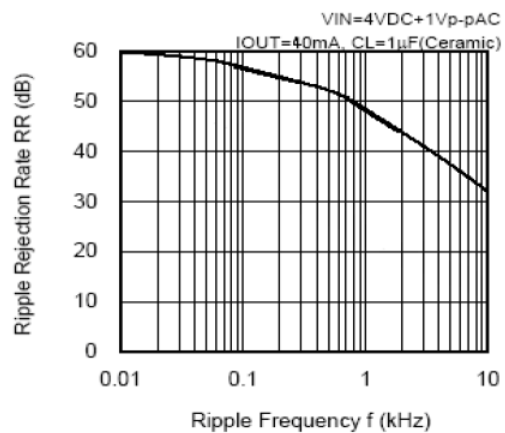



Transient Response

7. Input Transient Response

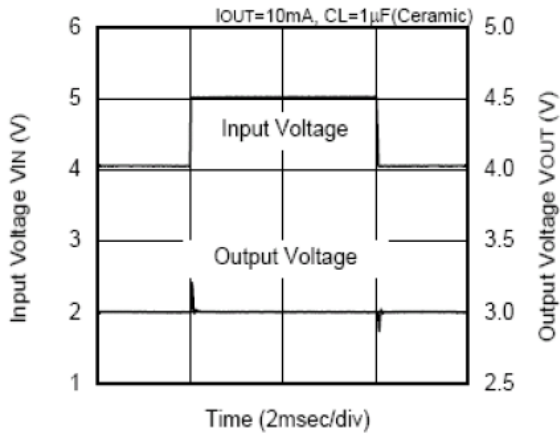

8. Load Transient Response

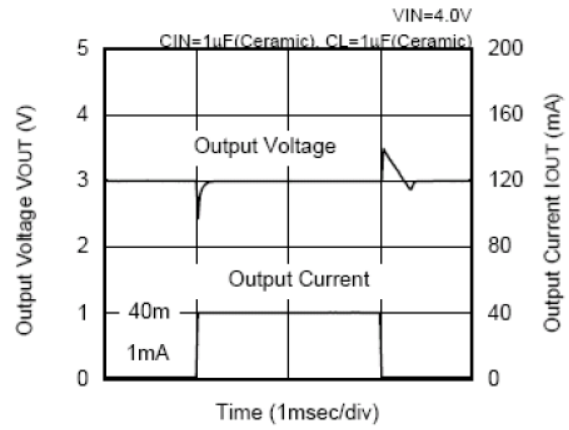

TEST CIRCUIT

Circuits 1

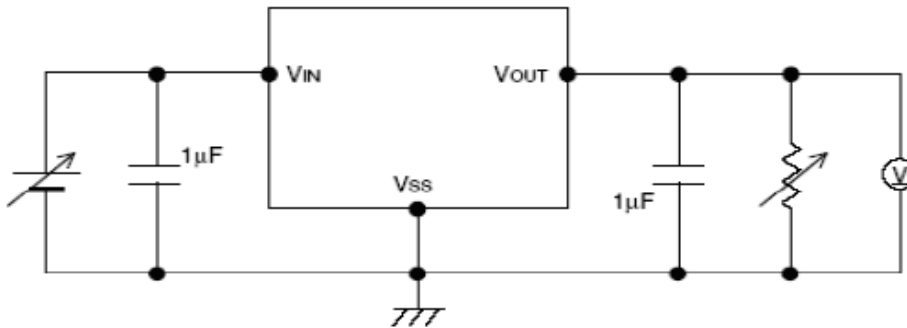

Circuits 2

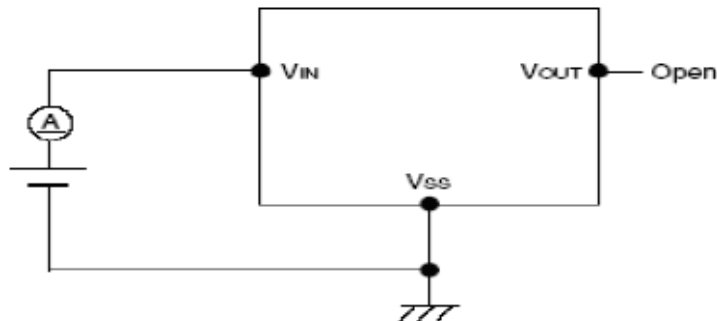



BLOCK DIAGRAM

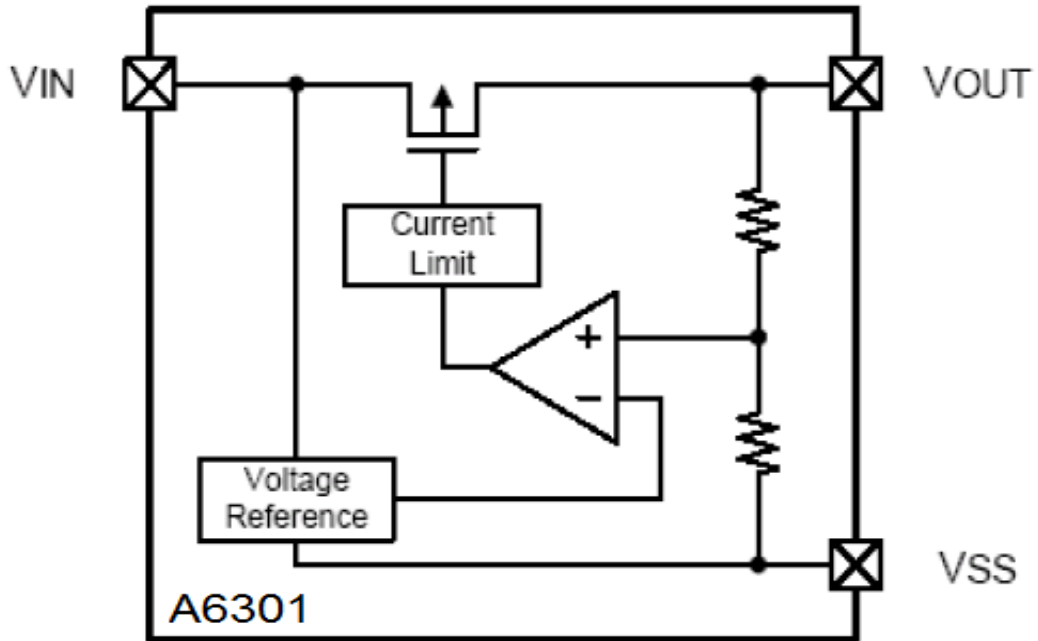



PACKAGE INFORMATION

Dimension in SOT-23 (Unit: mm)

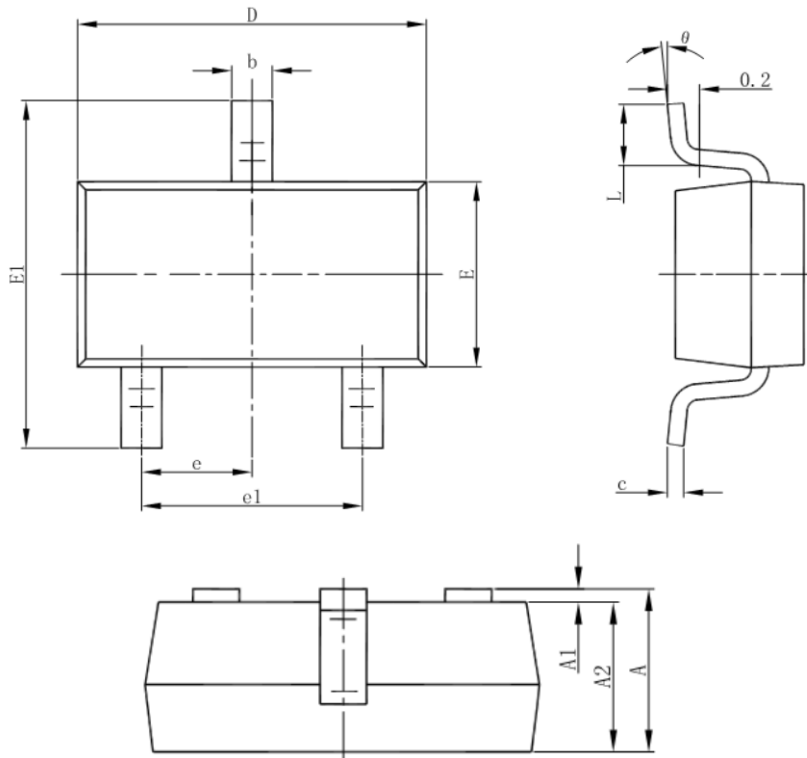

Symbol	Min	Max
A	1.050	1.250
A1	0.000	0.100
A2	1.050	1.150
b	0.300	0.500
c	0.100	0.200
D	2.820	3.020
E	1.500	1.700
E1	2.650	2.950
e	0.950(BSC)	
e1	1.800	2.000
L	0.300	0.600
θ	0°	8°



Dimension in SOT-89-3 (Unit: mm)

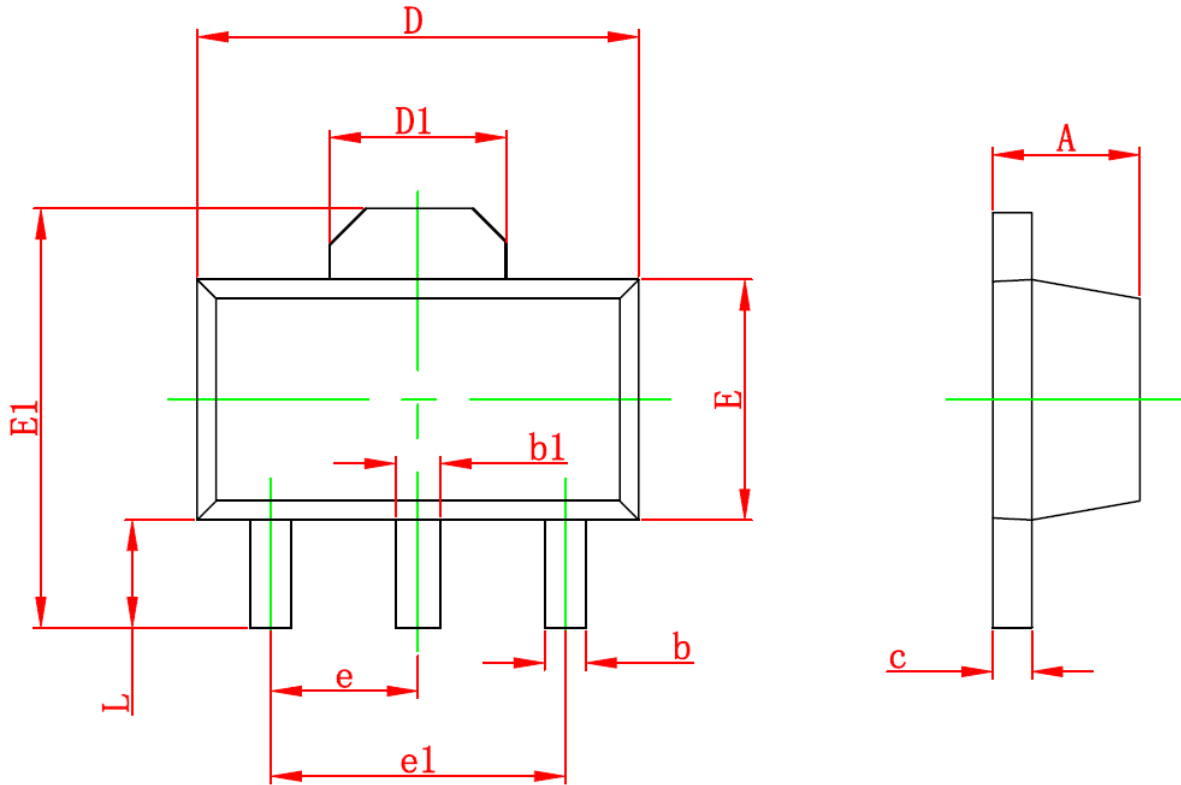

Symbol	Min	Max
A	1.400	1.600
b	0.320	0.520
b1	0.400	0.580
c	0.350	0.440
D	4.400	4.600
D1	1.550 REF	
E	2.300	2.600
E1	3.940	4.250
e	1.500 TYP	
e1	3.000 TYP	
L	0.900	1.200



IMPORTANT NOTICE

AiT Semiconductor Inc. (AiT) reserves the right to make changes to any its product, specifications, to discontinue any integrated circuit product or service without notice, and advises its customers to obtain the latest version of relevant information to verify, before placing orders, that the information being relied on is current.

AiT Semiconductor Inc.'s integrated circuit products are not designed, intended, authorized, or warranted to be suitable for use in life support applications, devices or systems or other critical applications. Use of AiT products in such applications is understood to be fully at the risk of the customer. As used herein may involve potential risks of death, personal injury, or severe property, or environmental damage. In order to minimize risks associated with the customer's applications, the customer should provide adequate design and operating safeguards.

AiT Semiconductor Inc. assumes to no liability to customer product design or application support. AiT warrants the performance of its products of the specifications applicable at the time of sale.