



## DESCRIPTION

The A6301A series are highly precise, low power consumption, positive voltage regulators manufactured using CMOS and laser trimming technologies. The series provides large currents with a significantly small dropout voltage. The A6301A consists of a current limiter circuit, a driver transistor, a precision reference voltage and an error amplifier. Output voltage is selectable in 0.1V steps between 1.2V ~ 6.0V.

The A6301A is available in SOT-23, SOT-25 and SOT89-3 packages.

## FEATURES

- Output Voltage Range 1.2V to 6.0V (selectable in 100mV steps)
- Highly Accurate  $\pm 2\%$
- Dropout Voltage : 160mV @ 100mA (3.0V type)
- Low Power Consumption : 5.0 $\mu$ A (TYP.)
- Maximum Output Current : 300mA ( $V_{IN} \geq V_{OUT}+1V$ )
- Internal protector: current limiter and short protector
- Maximum Operating voltage: 7V
- Available in SOT-23, SOT-25 and SOT89-3 Packages

## ORDERING INFORMATION

Package Type	Part Number	
SOT-23 SPQ: 3,000pcs/Reel	E3	A6301AE3R-XX
		A6301AE3VR-XX
SOT-25 SPQ: 3,000pcs/Reel	E5	A6301AE5R-XX
		A6301AE5VR-XX
SOT89-3 SPQ: 1,000pcs/Reel	K3	A6301AK3R-XX
		A6301AK3VR-XX
Note	XX: Output Voltage V: Halogen free Package R: Tape & Reel	
AiT provides all RoHS products		

## APPLICATION

- Mobile phones
- Cordless phones
- Cameras, video recorders
- Portable games
- Portable AV equipment
- Reference voltage
- Battery powered equipment

## TYPICAL APPLICATION

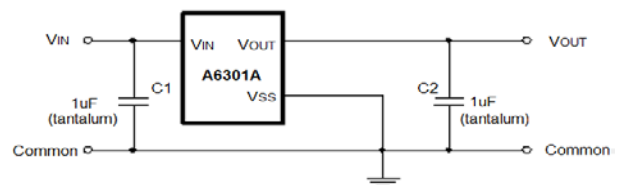

**Caution:** The above connection diagram and constant will not guarantee successful operation. Perform thorough evaluation using the actual application to set the constant.



## PIN DESCRIPTION

<p>Top View</p>			<p>Top View</p>			<p>Top View</p>		
Pin #			Symbol	Function				
SOT-23	SOT-25	SOT89-3						
1	2	1	V <sub>SS</sub>	Ground				
2	5	3	V <sub>OUT</sub>	Output Voltage				
3	1	2	V <sub>IN</sub>	Input Voltage				
-	3	-	CE	Chip enable				
-	4	-	NC	No connect				

## ABSOLUTE MAXIMUM RATINGS

V <sub>IN</sub> , Input Voltage	V <sub>SS</sub> -0.3V ~ V <sub>SS</sub> +10V	
V <sub>OUT</sub> , Output Voltage	V <sub>SS</sub> -0.3V ~ V <sub>IN</sub> +0.3V	
P <sub>D</sub> , Power Dissipation	SOT-23	250mW
	SOT89-3	500mW
T <sub>OPR</sub> , Operating Ambient Temperature	-40°C ~ +85°C	
T <sub>STG</sub> , Storage Temperature	-40°C ~ +125°C	

Stresses above may cause permanent damage to the device. These are stress ratings only and functional operation of the device at these or any other conditions beyond those indicated in the Electrical Characteristics are not implied. Exposure to absolute maximum rating conditions for extended periods may affect device reliability.



## ELECTRICAL CHARACTERISTICS

Parameter	Symbol	Conditions	Min.	Typ.	Max.	Unit	Circuit	
Output Voltage	$V_{OUT(E)}$	$V_{IN} = V_{OUT(S)} + 1.0V, I_{OUT} = 40mA$	$V_{OUT(S)} \times 0.98$	$V_{OUT(S)}$	$V_{OUT(S)} \times 1.02$	V	1	
Output Current	$I_{OUT}$	$V_{IN} \geq V_{OUT(S)} + 1.0V$	300	-	-	mA	1	
Dropout Voltage	$V_{DROP}$	$I_{OUT} = 100mA$	$2.2V \leq V_{OUT(S)} \leq 2.5V$	-	0.20	0.28	V	1
			$2.6V \leq V_{OUT(S)} \leq 3.3V$	-	0.16	0.24		
			$3.4V \leq V_{OUT(S)} \leq 5.5V$	-	0.12	0.20		
Line Regulation	$\frac{\Delta V_{OUT1}}{\Delta V_{IN} \times V_{OUT}}$	$V_{OUT(S)} + 0.5V \leq V_{IN} \leq 7V$ $I_{OUT} = 80mA$	-	0.05	0.3	%/V	1	
Load Regulation	$\Delta V_{OUT2}$	$V_{IN} = V_{OUT(S)} + 1.0V$ $1.0mA \leq I_{OUT} \leq 80mA$	-	20	40	mV		
Output Voltage Temperature Coefficient	$\frac{\Delta V_{OUT}}{\Delta T_A \times V_{OUT}}$	$V_{IN} = V_{OUT(S)} + 1.0V$ $I_{OUT} = 10mA$ $-40^\circ C \leq T_A \leq 85^\circ C$	-	$\pm 100$	-	ppm/ °C		
Supply Current	$I_{SS1}$	$V_{IN} = V_{OUT(S)} + 1.0V$	-	5	6.5	µA	2	
Input Voltage	$V_{IN}$		1.8	-	7	V	-	
Ripple-Rejection	RR	$V_{IN} = V_{OUT(S)} + 1.0V, f = 1.0kHz$ $V_{RIP} = 0.5V_{rms}, I_{OUT} = 80mA$	-	50	-	dB	1	
Short Current	$I_{SHORT}$	$V_{IN} = V_{OUT(S)} + 1.5V$	-	60	-	mA	1	
Current Limiter	$I_{LIM}$	$V_{IN} = V_{OUT(S)} + 1.5V$	-	380	-	mA	1	



## TYPICAL PERFORMANCE CHARACTERISTICS

### 3.0V Output

#### 1. Output Voltage vs. Temperature

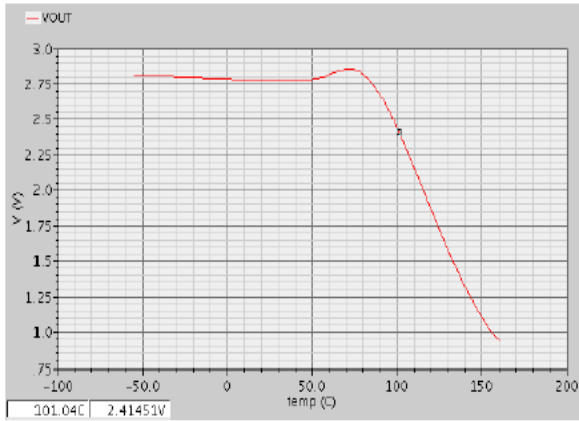

#### 2. Output Voltage vs. Input Voltage

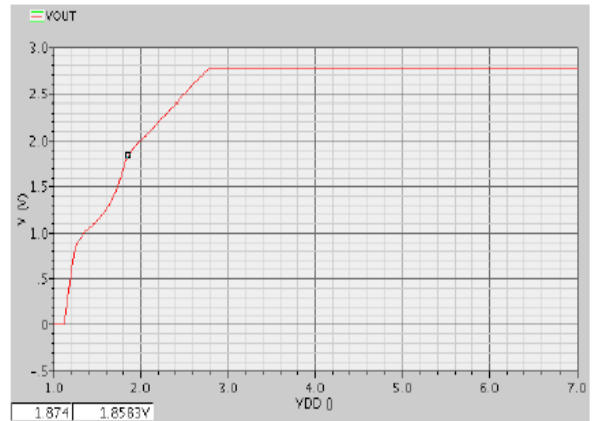

#### 3. I<sub>SS</sub> vs. Input Voltage

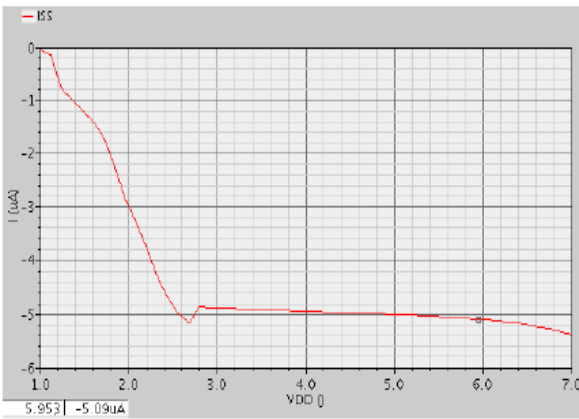

#### 4. Output Voltage vs. Output Current

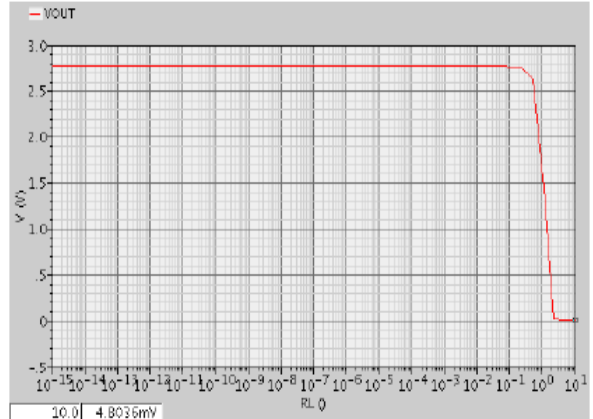

#### 5. Input Current vs. Load Current

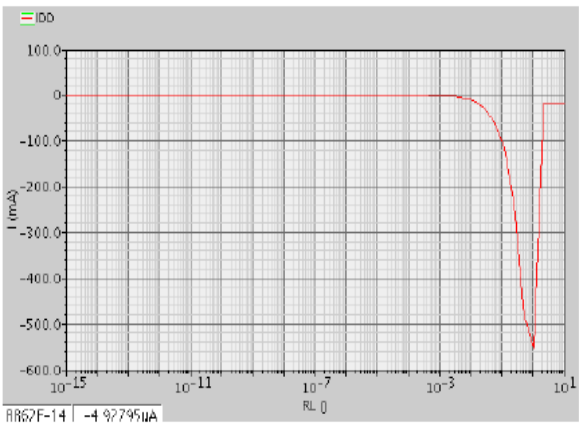



## TEST CIRCUIT

Circuits 1

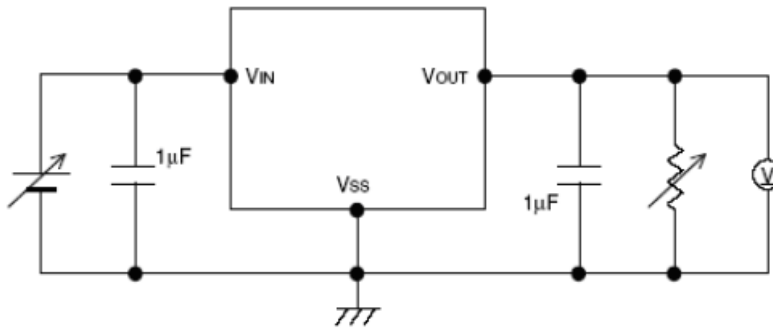

Circuits 2

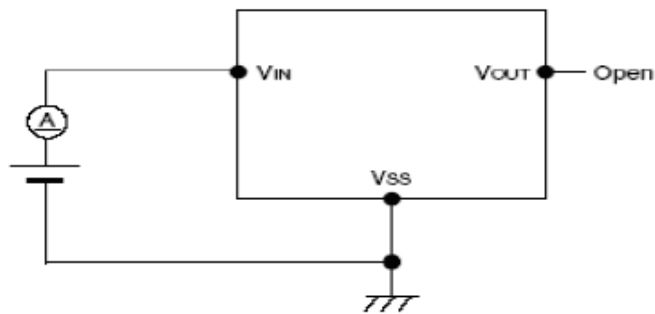

## BLOCK DIAGRAM

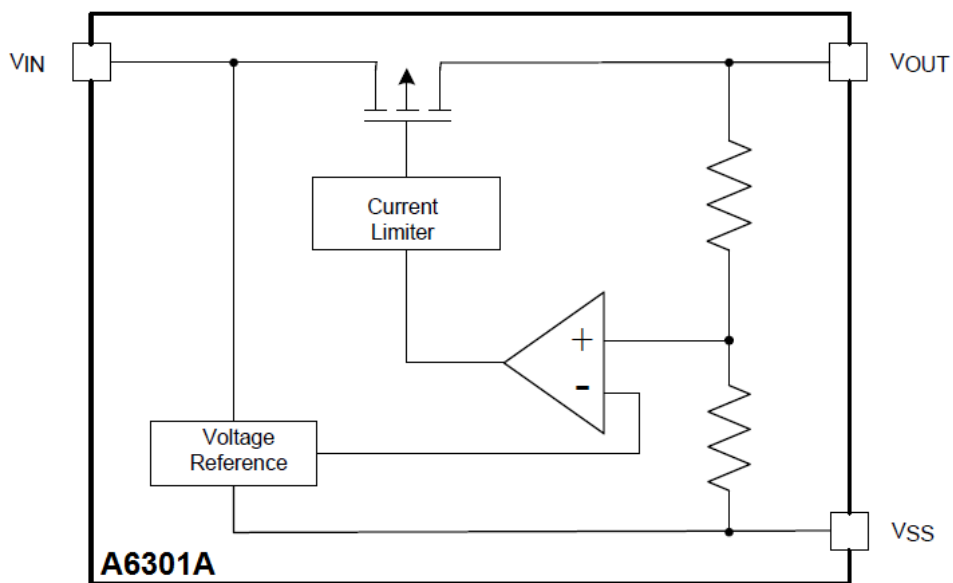



## PACKAGE INFORMATION

Dimension in SOT-23 (Unit: mm)

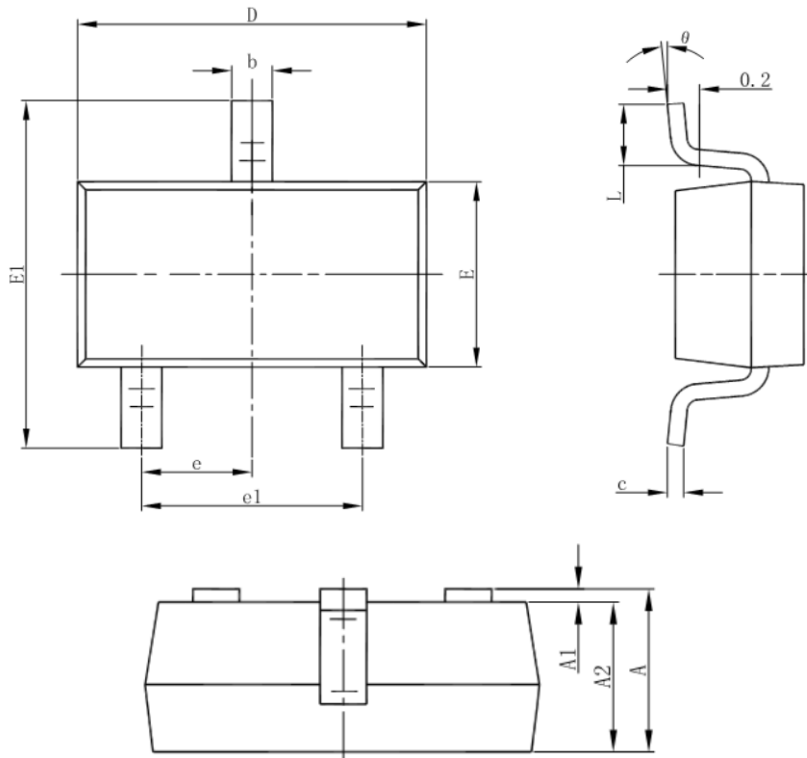

Symbol	Millimeters		Inches	
	Min	Max	Min	Max
A	1.050	1.250	0.041	0.049
A1	0.000	0.100	0.000	0.004
A2	1.050	1.150	0.041	0.045
b	0.300	0.500	0.012	0.020
c	0.100	0.200	0.004	0.008
D	2.820	3.020	0.111	0.119
E	1.500	1.700	0.059	0.067
E1	2.650	2.950	0.104	0.116
e	0.950 BSC		0.037 BSC	
e1	1.800	2.000	0.071	0.079
L	0.300	0.600	0.012	0.024
theta	0°	8°	0°	8°



Dimension in SOT-25 (Unit: mm)

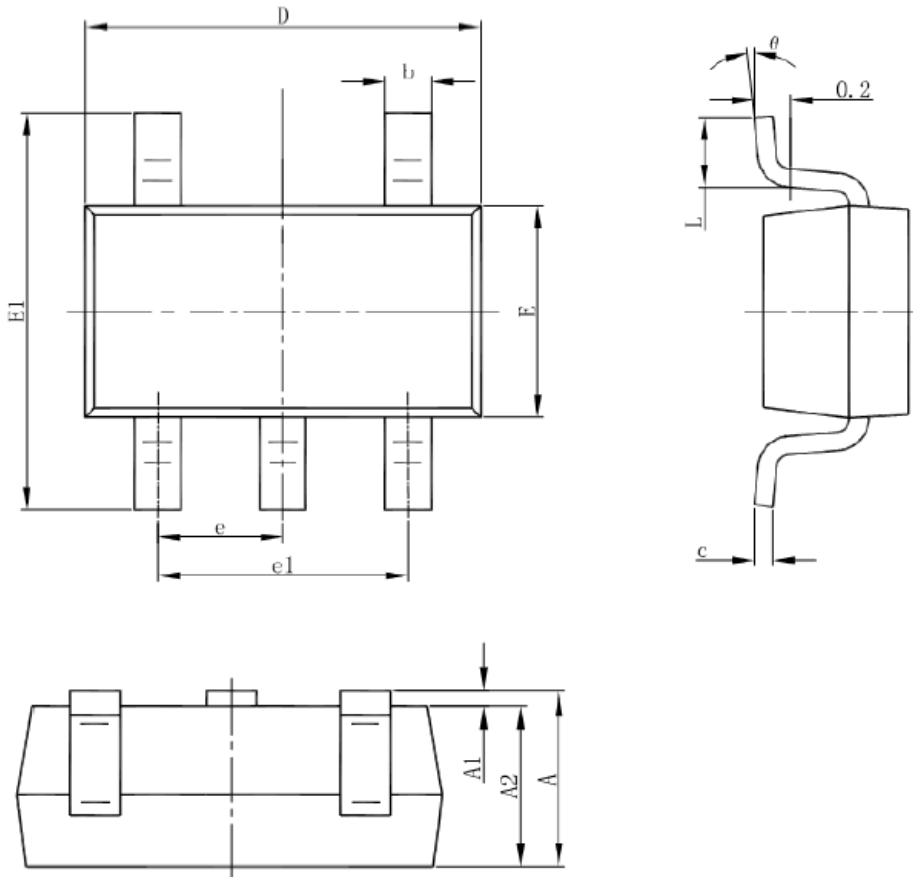

Symbol	Millimeters		Inches	
	Min	Max	Min	Max
A	1.050	1.250	0.041	0.049
A1	0.000	0.100	0.000	0.004
A2	1.050	1.150	0.041	0.045
b	0.300	0.500	0.012	0.020
c	0.100	0.200	0.004	0.008
D	2.820	3.020	0.111	0.119
E	1.500	1.700	0.059	0.067
E1	2.650	2.950	0.104	0.116
e	0.950 BSC		0.037 BSC	
e1	1.800	2.000	0.071	0.079
L	0.300	0.600	0.012	0.024
theta	0°	8°	0°	8°



Dimension in SOT89-3 (Unit: mm)

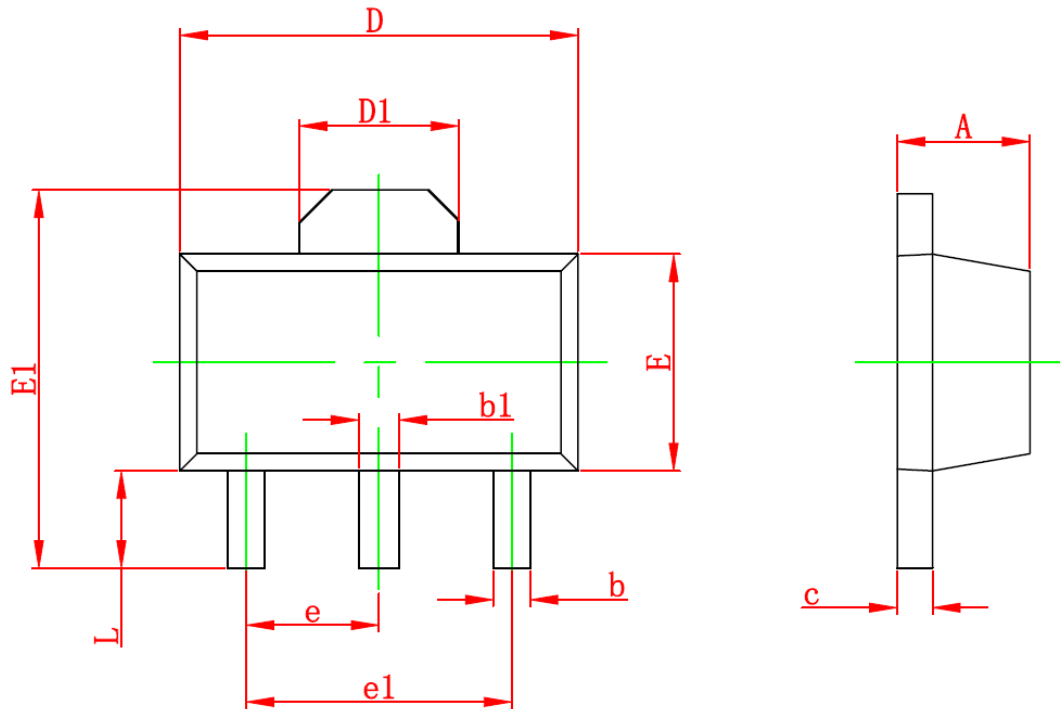

Symbol	Millimeters		Inches	
	Min	Max	Min	Max
A	1.400	1.600	0.055	0.063
b	0.320	0.520	0.013	0.020
b1	0.400	0.580	0.016	0.023
c	0.350	0.440	0.014	0.017
D	4.400	4.600	0.173	0.181
D1	1.550 REF		0.061REF	
E	2.300	2.600	0.091	0.102
E1	3.940	4.250	0.155	0.167
e	1.500 TYP		0.060 TYP	
e1	3.000 TYP		0.118 TYP	
L	0.900	1.200	0.035	0.047





## IMPORTANT NOTICE

AiT Semiconductor Inc. (AiT) reserves the right to make changes to any its product, specifications, to discontinue any integrated circuit product or service without notice, and advises its customers to obtain the latest version of relevant information to verify, before placing orders, that the information being relied on is current.

AiT Semiconductor Inc.'s integrated circuit products are not designed, intended, authorized, or warranted to be suitable for use in life support applications, devices or systems or other critical applications. Use of AiT products in such applications is understood to be fully at the risk of the customer. As used herein may involve potential risks of death, personal injury, or server property, or environmental damage. In order to minimize risks associated with the customer's applications, the customer should provide adequate design and operating safeguards.

AiT Semiconductor Inc. assumes to no liability to customer product design or application support. AiT warrants the performance of its products of the specifications applicable at the time of sale.