

A6833

DABiC-5 32-Bit Serial Input Latched Sink Drivers

A6833SEP
44-pin PLCC

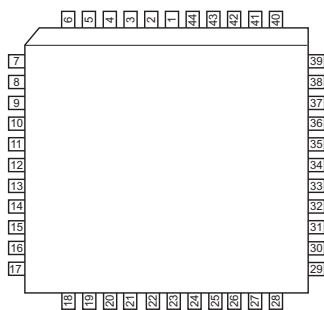

ABSOLUTE MAXIMUM RATINGS

Output Voltage, V_{OUT}	30 V
Logic Supply Voltage, V_{DD}	7 V
Input Voltage Range, V_{IN}	-0.3 V to $V_{DD}+0.3$ V
Continuous Output Current (each output), I_{OUT} ...	125 mA
Package Power Dissipation, P_D	
A6833SA	3.5 W*
A6833SEP	2.5 W*
Operating Temperature Range	
Ambient Temperature, T_A	-20°C to +85°C
Storage Temperature, T_S	-55°C to +150°C

*Derate linearly to 0W at +150°C.

Caution: CMOS devices have input-static protection, but are susceptible to damage when exposed to extremely high static-electrical charges.

Designed to reduce logic supply current, chip size, and system cost, the A6833 integrated circuits offer high-speed operation for thermal printers. These devices can also be used to drive multiplexed LED displays or incandescent lamps within their 125 mA peak output current rating. The combination of bipolar and MOS technologies gives the A6833 smart power ICs an interface flexibility beyond the reach of standard buffers and power driver circuits.

These 32-bit drivers have bipolar open-collector npn Darlington outputs, a CMOS data latch for each of the drivers, a 32-bit CMOS shift register, and CMOS control circuitry. The high-speed CMOS shift registers and latches allow operation with most microprocessor-based systems. Use of these drivers with TTL may require input pull-up resistors to ensure an input logic high. CMOS serial data outputs permit cascading for applications requiring additional drive lines.

The A6833 is supplied in a 44-lead plastic chip carrier (quad pack), intended for surface mounting on solder lands with 0.050 in. (1.27 mm) centers. These devices are lead (Pb) free, with 100% matte tin plated leadframes.

FEATURES

- 3.3 V to 5 V logic supply range
- To 10 MHz data input rate
- 30 V minimum output breakdown
- Darlington current-sink outputs
- Low-power CMOS logic and latches
- Schmitt trigger inputs for improved noise immunity

APPLICATIONS

- Thermal printheads
- Multiplexed LED displays
- Incandescent lamps



Use the following complete part numbers when ordering:

Part Number	Pins	Package
A6833SEP-T	44	PLCC

A6833

DABiC-5 32-Bit Serial-Input Latched Sink Drivers

Functional Block Diagram

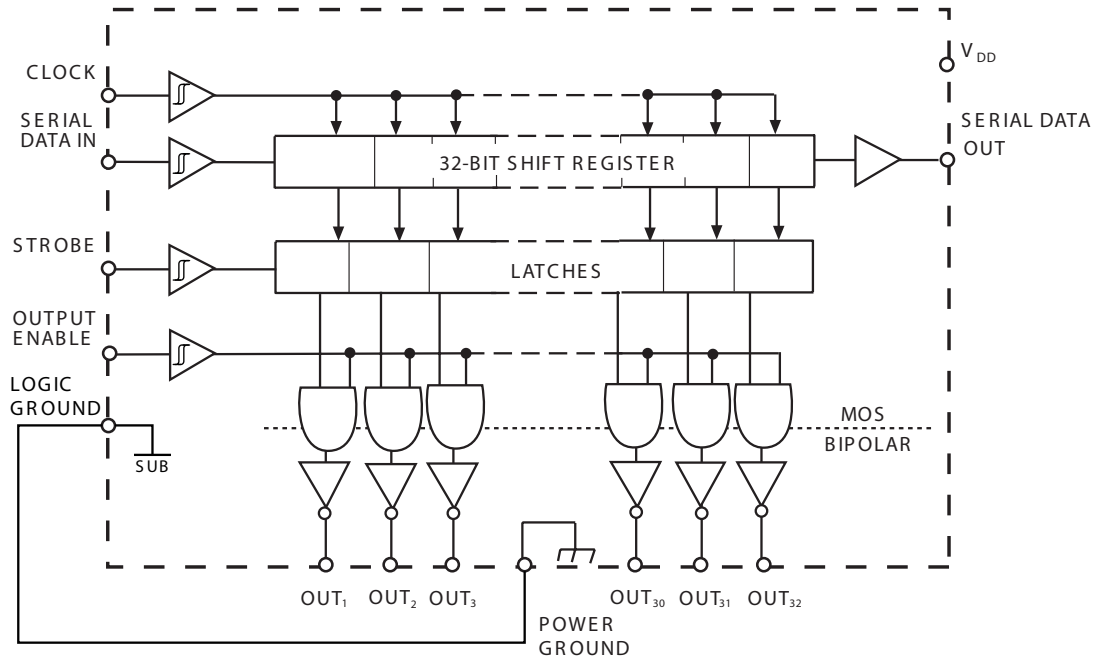

Typical Input Circuit

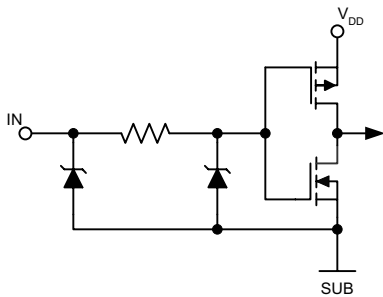

Typical Output Driver

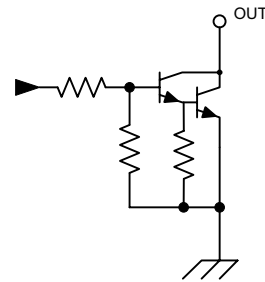

A6833

DABiC-5 32-Bit Serial-Input Latched Sink Drivers

ELECTRICAL CHARACTERISTICS¹ Unless otherwise noted: $T_A = 25^\circ\text{C}$, logic supply operating voltage $V_{dd} = 3.0\text{V}$ to 5.5V

Characteristic	Symbol	Test Conditions	$V_{dd} = 3.3\text{V}$			$V_{dd} = 5\text{V}$			Units
			Min.	Typ.	Max.	Min.	Typ.	Max.	
Output Leakage Current	I_{CEX}	$V_{OUT} = 30\text{V}$	–	–	10	–	–	10	μA
Collector–Emitter Saturation Voltage	$V_{CE(SAT)}$	$I_{OUT} = 50\text{mA}$	–	–	0.7	–	–	0.7	V
		$I_{OUT} = 100\text{mA}$	–	–	1.0	–	–	1.0	V
Input Voltage	$V_{IN(1)}$		2.2	–	–	3.3	–	–	V
	$V_{IN(0)}$		–	–	1.1	–	–	1.7	V
Input Current	$I_{IN(1)}$	$V_{IN} = V_{DD}$	–	< 0.01	1.0	–	< 0.01	1.0	μA
	$I_{IN(0)}$	$V_{IN} = 0\text{V}$	–	< –0.01	–1.0	–	< –0.01	–1.0	μA
Serial Data Output Voltage	$V_{OUT(1)}$	$I_{OUT} = -200\mu\text{A}$	2.8	3.05	–	4.5	4.75	–	V
	$V_{OUT(0)}$	$I_{OUT} = 200\mu\text{A}$	–	0.15	0.3	–	0.15	0.3	V
Maximum Clock Frequency ²	f_c		10	–	–	10	–	–	MHz
Logic Supply Current	$I_{DD(1)}$	One output on, $I_{OUT} = 100\text{mA}$	–	–	2.0	–	–	2.0	mA
	$I_{DD(0)}$	All outputs off	–	–	100	–	–	100	μA
Output Enable-to-Output Delay	$t_{dis(BQ)}$	$V_{CC} = 50\text{V}$, $R_1 = 500\Omega$, $C_1 \leq 30\text{pF}$	–	–	1.0	–	–	1.0	μs
	$t_{en(BQ)}$	$V_{CC} = 50\text{V}$, $R_1 = 500\Omega$, $C_1 \leq 30\text{pF}$	–	–	1.0	–	–	1.0	μs
Strobe-to-Output Delay	$t_{p(STH-QL)}$	$V_{CC} = 50\text{V}$, $R_1 = 500\Omega$, $C_1 \leq 30\text{pF}$	–	–	1.0	–	–	1.0	μs
	$t_{p(STH-QH)}$	$V_{CC} = 50\text{V}$, $R_1 = 500\Omega$, $C_1 \leq 30\text{pF}$	–	–	1.0	–	–	1.0	μs
Output Fall Time	t_f	$V_{CC} = 50\text{V}$, $R_1 = 500\Omega$, $C_1 \leq 30\text{pF}$	–	–	500	–	–	500	ns
Output Rise Time	t_r	$V_{CC} = 50\text{V}$, $R_1 = 500\Omega$, $C_1 \leq 30\text{pF}$	–	–	500	–	–	500	ns
Clock-to-Serial Data Out Delay	$t_{p(CH-SQX)}$	$I_{OUT} = \pm 200\mu\text{A}$	–	50	–	–	50	–	ns

¹Positive (negative) current is defined as conventional current going into (coming out of) the specified device pin.

²Operation at a clock frequency greater than the specified minimum value is possible but not warranted.

Truth Table

Serial Data Input	Clock Input	Shift Register Contents						Serial Data Output	Strobe Input	Latch Contents						Output Enable Input	Output Contents					
		I_1	I_2	I_3	...	I_{N-1}	I_N			I_1	I_2	I_3	...	I_{N-1}	I_N		I_1	I_2	I_3	...	I_{N-1}	I_N
H		H	R_1	R_2	...	R_{N-2}	R_{N-1}	R_{N-1}														
L		L	R_1	R_2	...	R_{N-2}	R_{N-1}	R_{N-1}														
X		R_1	R_2	R_3	...	R_{N-1}	R_N	R_N														
		X	X	X	...	X	X	X	L	R_1	R_2	R_3	...	R_{N-1}	R_N							
		P_1	P_2	P_3	...	P_{N-1}	P_N	P_N	H	P_1	P_2	P_3	...	P_{N-1}	P_N	H	P_1	P_2	P_3	...	P_{N-1}	P_N
										X	X	X	...	X	X	L	H	H	H	...	H	H

L = Low Logic Level
H = High Logic Level
X = Irrelevant

P = Present State
R = Previous State

A6833

DABiC-5 32-Bit Serial-Input Latched Sink Drivers

Timing Requirements and Specifications (Logic Levels are V_{DD} and Ground)

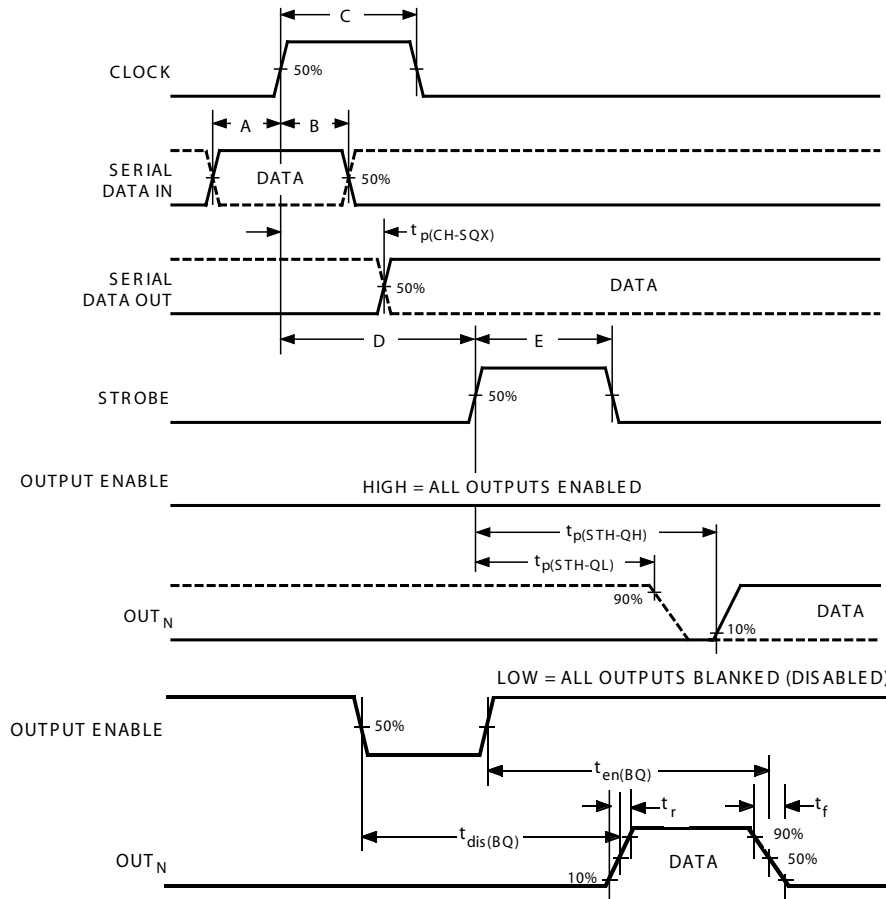

Key	Description	Symbol	Time (ns)
A	Data Active Time Before Clock Pulse (Data Set-Up Time)	$t_{su(D)}$	25
B	Data Active Time After Clock Pulse (Data Hold Time)	$t_h(D)$	25
C	Clock Pulse Width	$t_w(CH)$	50
D	Time Between Clock Activation and Strobe	$t_{su(C)}$	100
E	Strobe Pulse Width	$t_w(STH)$	50

NOTE: Timing is representative of a 10 MHz clock. Higher speeds may be attainable; operation at high temperatures will reduce the specified maximum clock frequency.

Serial Data present at the input is transferred to the shift register on the logical 0 to logical 1 transition of the CLOCK input pulse. On succeeding CLOCK pulses, the registers shift data information towards the SERIAL DATA OUTPUT. The SERIAL DATA must appear at the input prior to the rising edge of the CLOCK input waveform.

Information present at any register is transferred to the respective latch when the STROBE is high (serial-to-parallel conversion). The

latches will continue to accept new data as long as the STROBE is held high. Applications where the latches are bypassed (STROBE tied high) will require that the OUTPUT ENABLE input be low during serial data entry.

When the OUTPUT ENABLE input is low, the output sink drivers are disabled (OFF). The information stored in the latches is not affected by the OUTPUT ENABLE input. With the OUTPUT ENABLE input high, the outputs are controlled by the state of their respective latches.

A6833

DABiC-5 32-Bit Serial-Input Latched Sink Drivers

A6833SEP

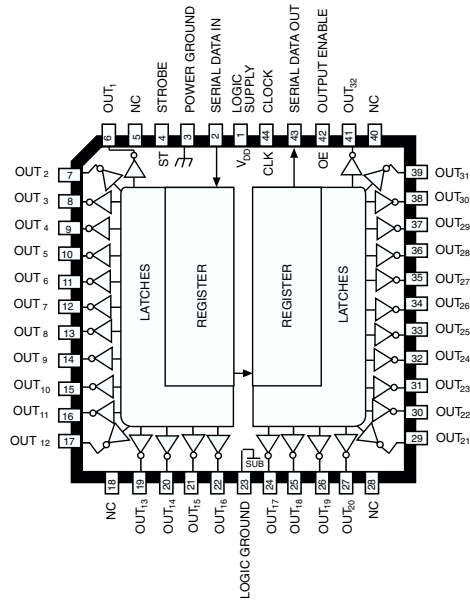

A6833

DABiC-5 32-Bit Serial-Input Latched Sink Drivers

A6833SEP

Dimensions in Inches
(controlling dimensions)

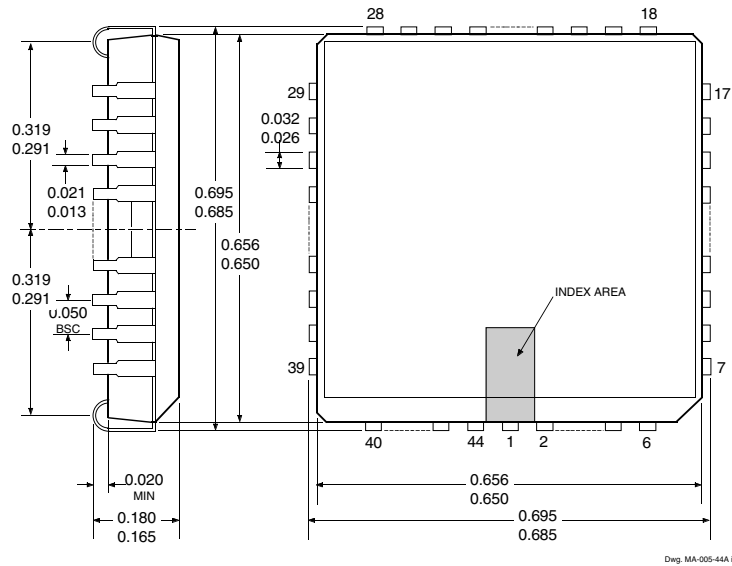

Dimensions in Millimeters
(for reference only)

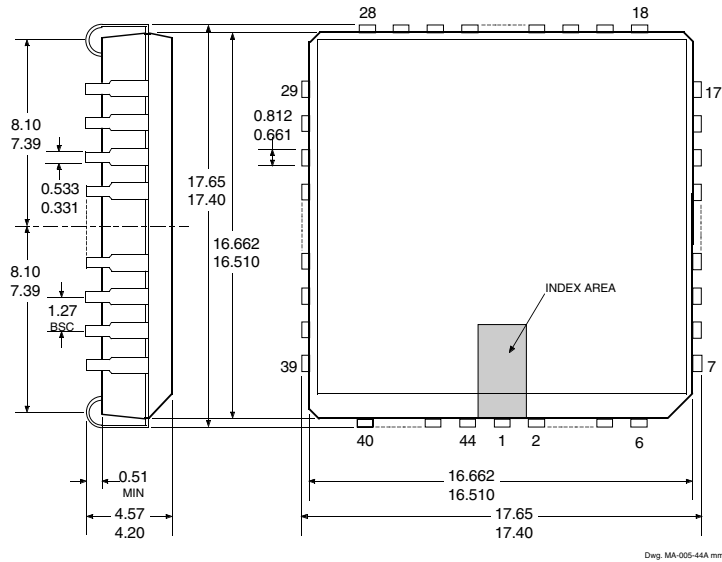

- NOTES: 1. Exact body and lead configuration at vendor's option within limits shown.
2. Lead spacing tolerance is non-cumulative.

A6833 *DABiC-5 32-Bit Serial-Input Latched Sink Drivers*

The products described here are manufactured under one or more U.S. patents or U.S. patents pending.

Allegro MicroSystems, Inc. reserves the right to make, from time to time, such departures from the detail specifications as may be required to permit improvements in the performance, reliability, or manufacturability of its products. Before placing an order, the user is cautioned to verify that the information being relied upon is current.

Allegro products are not authorized for use as critical components in life-support devices or systems without express written approval.

The information included herein is believed to be accurate and reliable. However, Allegro MicroSystems, Inc. assumes no responsibility for its use; nor for any infringement of patents or other rights of third parties which may result from its use.

Copyright©2003, 2004, 2005 AllegroMicrosystems, Inc.

