



DESCRIPTION

The A7208 is a dual constant frequency, 1.5MHz, slope compensated current mode PWM step-down converter working under an input voltage range of 2.5V to 5.5V. This feature makes the A7208 suitable for single cell Li-ion battery-powered applications. The internal synchronous rectifier is desired to increase efficiency without an external Schottky diode. 100% duty cycle capability extends battery life in portable devices, while the quiescent current is 180µA at no load, and drops to < 1µA in shutdown. Pulse Skipping Mode operation increases efficiency at light loads, further extending battery life.

Low output voltage ripple and small external inductor and capacitor sizes are achieved with 1.5MHz switching frequency.

The A7208 is available in PSOP8 package.

ORDERING INFORMATION

Package Type	Part Number	
PSOP8	MP8	A7208MP8R-XXZ
		A7208MP8VR-XXZ
Note	XX: 18=1.8V, ADJ=Adjustable Z: Pin Define See Pin Description V: Green Package R : Tape & Reel	
AiT provides all Pb free products Suffix " V " means Green Package		

FEATURES

- High Efficiency: Up to 96%
- 1.5MHz Constant Switching Frequency
- Current Mode Operation for Excellent Line and Load Transient Response
- No Schottky Diode Required
- 2.5V to 5.5V Input Voltage Range
- Adjustable Output Voltage
- 100% Duty Cycle in Dropout Mode
- Output Current: Up to 800mA per Channel
- Low Quiescent Current: 180µA each
- Over temperature Protection
- Short Circuit Protection
- Shutdown Quiescent Current < 1µA
- Available in PSOP8 package

APPLICATIONS

- Cellular and Smart Phones
- Wireless Handsets and DSL Modems
- Microprocessors and DSP Core Supplies
- PDAs
- Digital Still and Video Cameras
- MP3/MP4/MP5 Players
- Portable Instruments
- GPS Receivers

TYPICAL APPLICATION

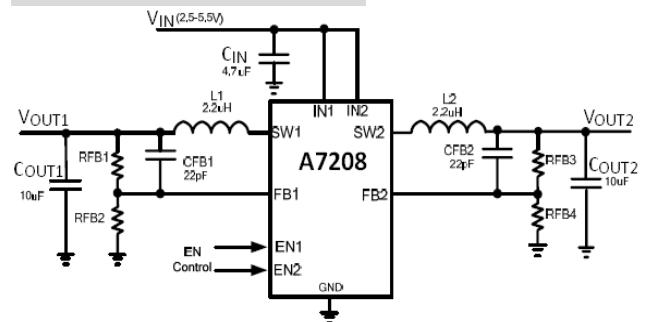

A7208-ADJ (Adjustable Type)



PIN DESCRIPTION

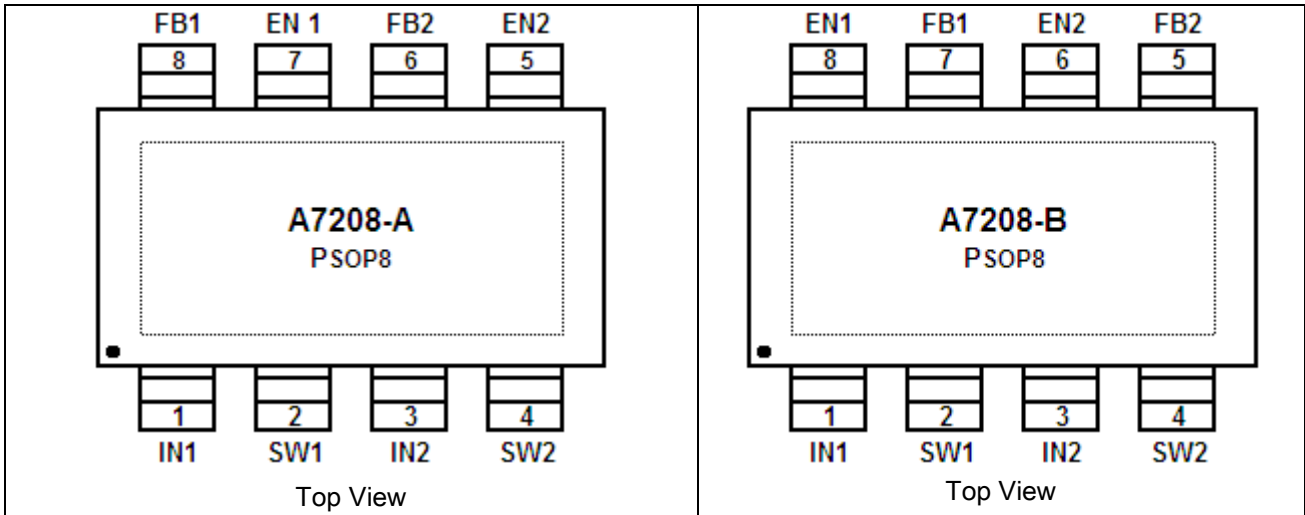

Pin #		Symbol	Function
A7208-XXA	A7208-XXB		
1	1	IN1	Supply Input Pin. Must be closely decoupled to GND with a 2.2μF or greater ceramic capacitor.
2	2	SW1	Power Switch Output. It is the switch node connection to external inductor. This pin connects to the drains of the internal P-Channel and N-Channel MOSFET switches.
3	3	IN2	Supply Input Pin. Must be closely decoupled to GND with a 2.2μF or greater ceramic capacitor.
4	4	SW2	Power Switch Output. It is the switch node connection to external inductor. This pin connects to the drains of the internal P-Channel and N-Channel MOSFET switches.
5	6	EN2	Regulator Enable Control Input. Drive EN above 1.5V to turn on the part. Drive EN below 0.3V to turn it off. In shutdown, all functions are disabled drawing <1μA supply current. Do not leave EN floating.
6	5	FB2	Feedback Input Pin. Connect FB to the center point of the external resistor divider. The regulated voltage on this pin is 0.6V.
7	8	EN1	Regulator Enable Control Input. Drive EN above 1.5V to turn on the part. Drive EN below 0.3V to turn it off. In shutdown, all functions are disabled drawing <1μA supply current. Do not leave EN floating.
8	7	FB1	Feedback Input Pin. Connect FB to the center point of the external resistor divider. The regulated voltage on this pin is 0.6V.
PAD		GND	Power Ground Pin.



ABSOLUTE MAXIMUM RATINGS

Input Supply Voltage(IN1,IN2)	-0.3V to +6V
EN1,EN2,VFB1,VFB2, Voltages	-0.3V to +V _{IN}
SW1,SW2, Voltages	-0.3V to (V _{IN} +0.3V)
P-Channel Switch Source Current (DC)	1A
N-Channel Switch Sink Current (DC)	1A
Peak SW Sink and Source Current	1.4A
Operating Temperature Range	-40°C to +85°C
Junction Temperature ^{NOTE}	+125°C
Storage Temperature Range	-65°C to +150°C
Lead Temperature (Soldering, 10s)	+300°C

Stresses above may cause permanent damage to the device. These are stress ratings only and functional operation of the device at these or any other conditions beyond those indicated in the Electrical Characteristics are not implied. Exposure to absolute maximum rating conditions for extended periods may affect device reliability.

NOTE: T_J is calculated from the ambient temperature T_A and power dissipation P_D according to the following formula:

$$T_J = T_A + (P_D) \times (50^\circ\text{C/W}).$$

THERMAL RESISTANCE

Package	θ _{JA}	θ _{JC}
PSOP8	50°C/W	10°C/W

NOTE: Thermal Resistance is specified with approximately 1 square of 1 oz copper.



ELECTRICAL CHARACTERISTICS

$V_{IN1} = V_{IN2} = V_{EN1} = V_{EN2} = 3.6V$, $T_A = 25^\circ C$, unless otherwise specified.

Parameter	Conditions	Min	Typ	Max	Units
Input Voltage Range		2.5	-	5.5	V
Input DC Supply Current Active Mode	$V_{FB}=0.5V$ or $V_{OUT}=90\%$	-	180	300	μA
	$V_{FB}=0V$, $V_{IN}=4.2V$		0.1	1.0	
Shutdown Mode	$V_{FB}=0V$, $V_{IN}=4.2V$				
Regulated Feedback Voltage	$T_A = +25^\circ C$	0.5880	0.6000	0.6120	V
	$T_A = 0^\circ C \leq T_A \leq 85^\circ C$	0.5865	0.6000	0.6135	
	$T_A = -40^\circ C \leq T_A \leq 85^\circ C$	0.5850	0.6000	0.6150	
V_{FB} Input Bias Current	$V_{FB} = 0.65V$	-	-	± 30	nA
Reference Voltage Line Regulation	$V_{IN} = 2.5V$ to $5.5V$	-	0.04	0.4	%/V
Output Overvoltage Lockout	$\Delta V_{OVL} = V_{OVL} - V_{FB}$, Adjustable Version	20	50	80	mV
Output Voltage Line Regulation	$V_{IN} = 2.5V$ to $5.5V$	-	0.04	0.40	%
Output Voltage Load Regulation		-	0.5	-	%
Peak Inductor Current	$V_{IN}=3V$, $V_{FB}=0.5V$ or $V_{OUT}=90\%$ Duty Cycle <35%	-	1.2	-	A
Oscillator Frequency	$V_{FB}=0.6V$ or $V_{OUT}=100\%$	1.2	1.5	1.8	MHz
$R_{DS(ON)}$ of P-CH MOSFET	$I_{SW} = 300mA$	-	0.40	0.50	Ω
$R_{DS(ON)}$ of N-CH MOSFET	$I_{SW} = -300mA$	-	0.35	0.45	Ω
SW Leakage Current	$V_{RUN} = 0V$, $V_{SW} = 0V$ or $5V$, $V_{IN} = 5V$	-	± 0.01	± 1	μA
EN Threshold	$-40^\circ C \leq T_A \leq 85^\circ C$	0.3	1.1	1.30	V
EN Leakage Current		-	± 0.01	± 1	μA



TYPICAL PERFORMANCE CHARACTERISTICS

1. Efficiency vs. Output Current

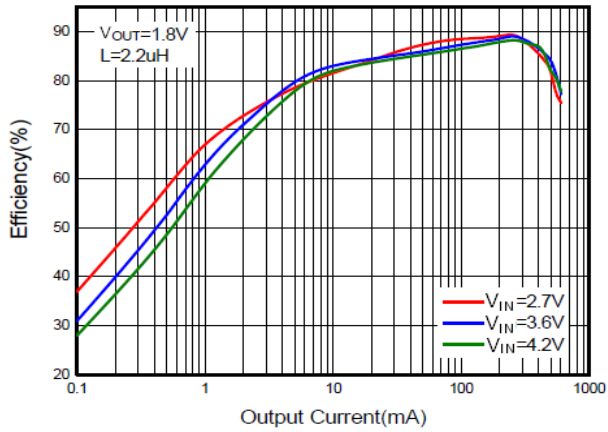

2. Output Voltage vs. Load Current

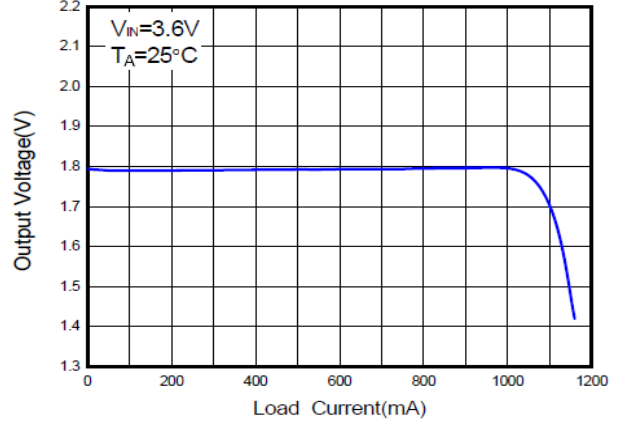

3. Reference Voltage vs. Temperature

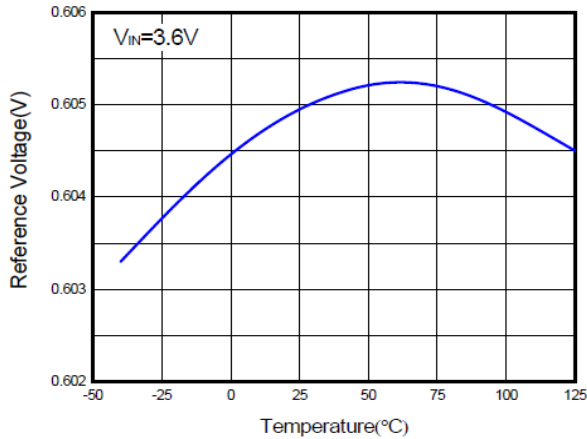

4. Output Voltage vs. Input Voltage

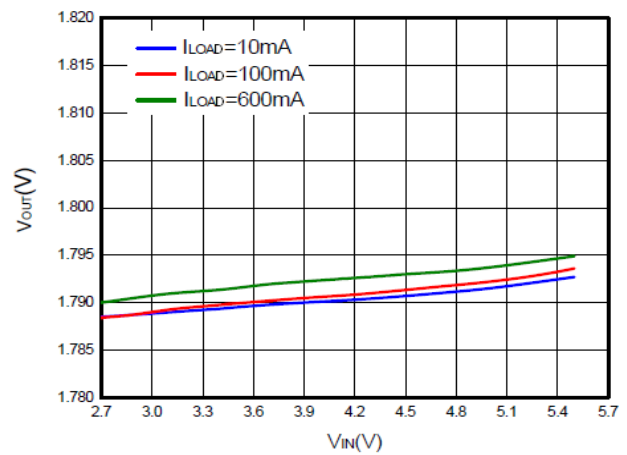

5. Supply Current vs. Supply Voltage

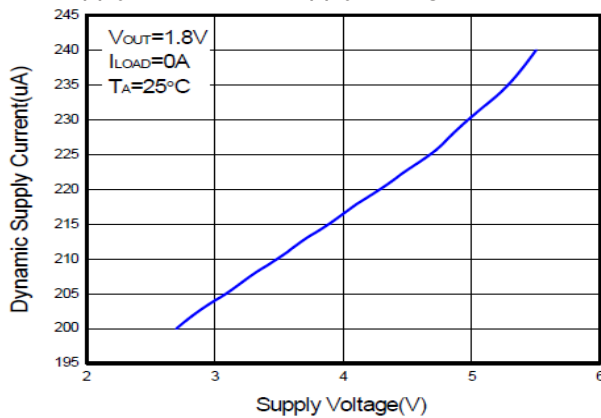

6. Start_up from Shutdown

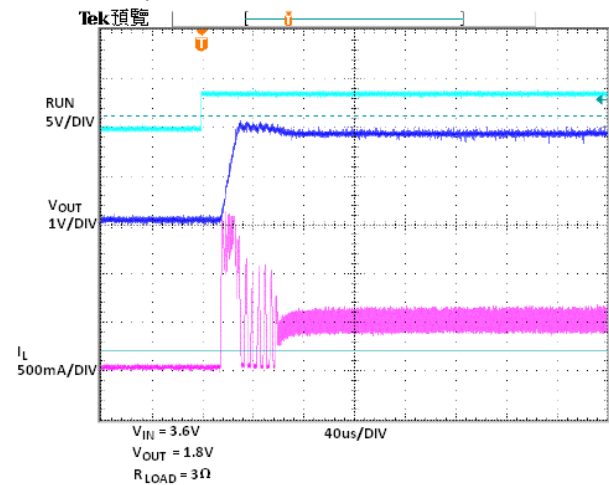



7. Load Step

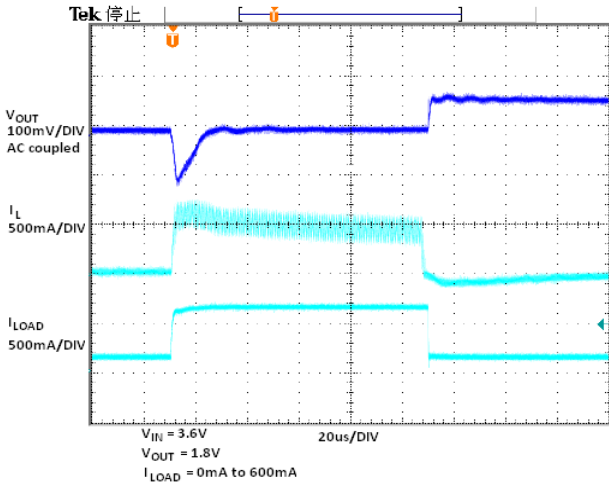

8. Load Step

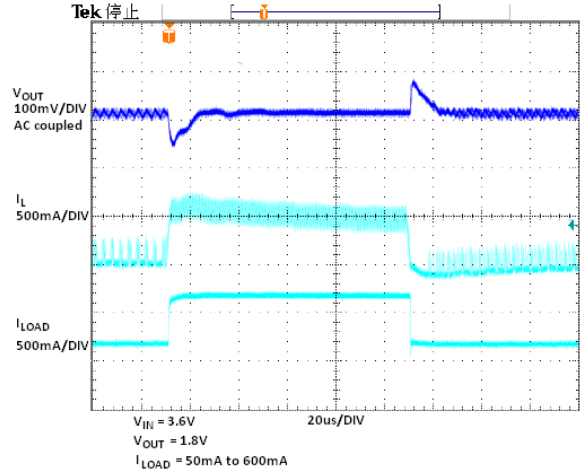

9. Load Step

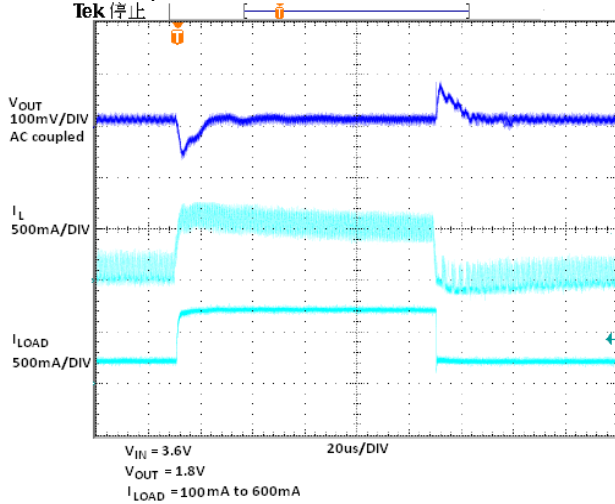

10. Load Step

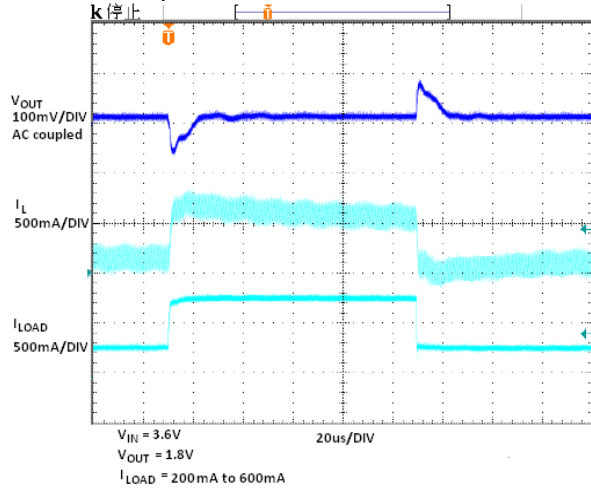

11. Pulse Skipping Mode

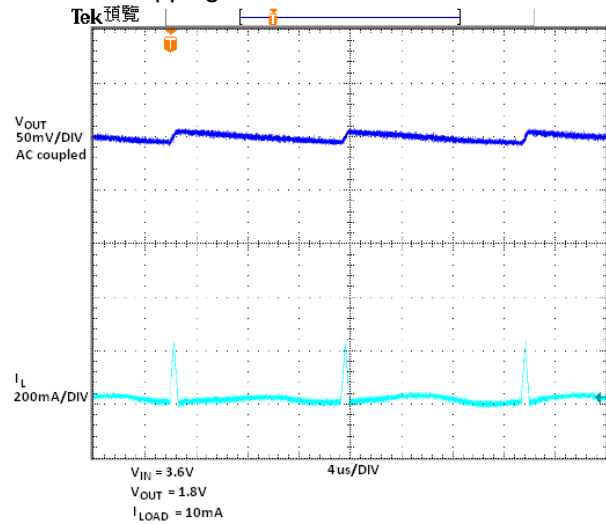

12. Output Short

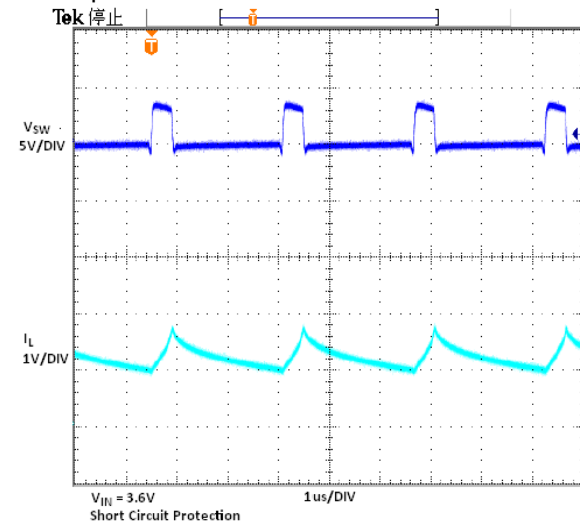



BLOCK DIAGRAM

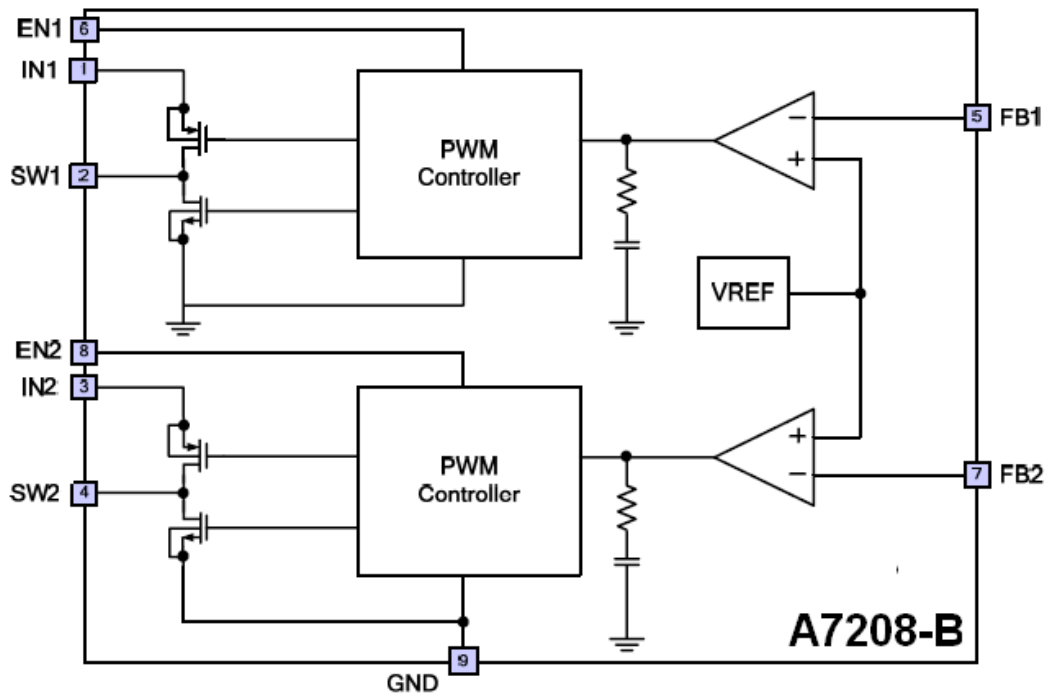
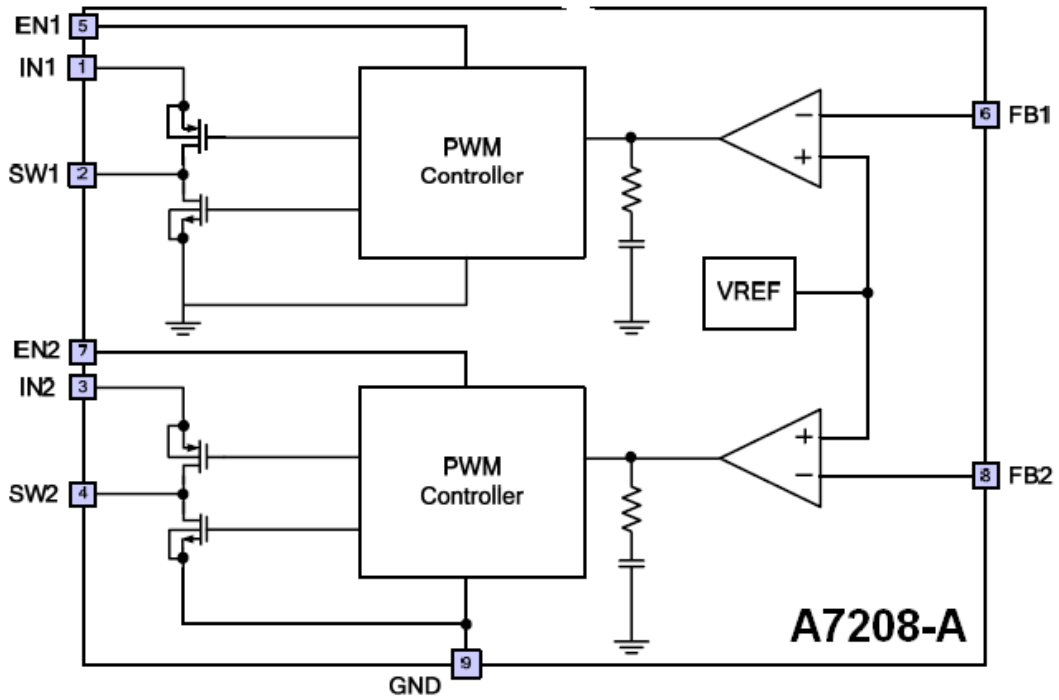



DETAILED INFORMATION

Operation

The A7208 uses a constant frequency, current mode step-down architecture. Both the main switch (P-channel MOSFET) and the synchronous rectifier (N-channel MOSFET) are integrated internally. This Step-Down DC-DC Converter can supply 800mA output current over a wide input voltage range from 2.5V to 5.5V. The over voltage comparator OVDET guards against transient overshoots >7.8% by turning the main switch off and keeping it off until the fault is removed.

Current Mode PWM Control

Slope compensated current mode PWM control provides stable switching and cycle-by-cycle current limit for excellent load and line responses. During normal operation, the internal main switch is turned on for a certain time to ramp the inductor current at each rising edge of the internal oscillator, and turned off when the peak inductor current reaches the controlled value. When the main switch is off, the synchronous rectifier will be turned on immediately and stay on until either the inductor current starts to reverse, as indicated by the current reversal comparator, I_{RCMP} , or the beginning of the next clock cycle.

Pulse Skipping Mode Operation

At very light loads, the A7208 will automatically enter Pulse Skipping Mode to increase efficiency, further extending battery life. In this mode, the control loop skips PWM pulses while maintaining output in regulation, and the switching frequency depends on the load condition. This is a kind of PFM mode operation.

Dropout Operation

When the input voltage decreases toward the value of the output voltage, the A7208 will keep the main switch on for more than one switching cycle and increases the duty cycle ^{Note 6} until it reaches 100%. The output voltage then is the input voltage minus the voltage drop across the main switch and the inductor. At low input supply voltage, the $R_{DS(ON)}$ of the P-Channel MOSFET increases, and the efficiency of the converter decreases. Caution must be exercised to ensure the heat dissipated not to exceed the maximum junction temperature of the IC.

Note: The duty cycle D of a step-down converter is defined as:

$$D = T_{ON} \times f_{OSC} \times 100\% \approx \frac{V_{OUT}}{V_{IN}} \times 100\%$$

Where T_{ON} is the main switch on time, and f_{OSC} is the oscillator frequency (1.5MHz).



Short Circuit Protection

The A7208 has short circuit protection. When output is shorted to ground, the oscillator frequency is reduced to prevent the inductor current from increasing beyond the PFET current limit. The PFET current limit is also reduced to lower the short circuit current. The frequency and current limit will return to the normal values once the short circuit condition is removed and the feedback voltage reaches 0.6V.

Maximum Load Current

The A7208 will operate with input supply voltage as low as 2.5V, however the maximum load current decreases at lower input voltage due to large IR drop on the main switch and synchronous rectifier.

Setting the Output Voltage

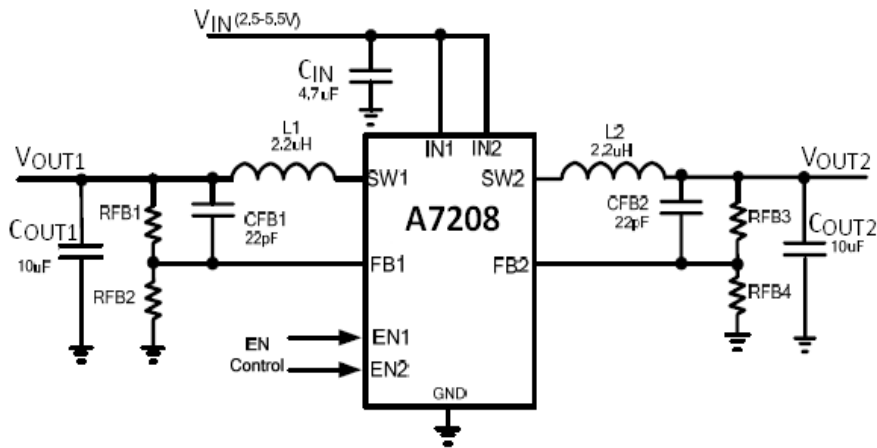

Figure 1. A7208-ADJ Typical Application

Figure 1 above shows the basic application circuit with A7208 adjustable output version. The external resistor sets the output voltage according to the following equation:

$$V_{OUT} = 0.6V \times \left(1 + \frac{R2}{R1}\right)$$

Table 1-Resistor Selection vs. Output Voltage Setting

V _{OUT}	R1	R2
1.0V	180 kΩ(1%)	120 kΩ(1%)
1.2V	180 kΩ(1%)	180 kΩ(1%)
1.5V	180 kΩ(1%)	270 kΩ(1%)
1.8V	180 kΩ(1%)	360 kΩ(1%)
2.5V	158 kΩ(1%)	499 kΩ(1%)
3.3V	180 kΩ(1%)	810 kΩ(1%)



Inductor Selection

The output inductor is selected to limit the ripple current to some predetermined value, typically 20%~40% of the full load current at the maximum input voltage. In continuous mode, the ripple current is determined by:

$$\Delta I_L = \frac{1}{f \times L} V_{OUT} \left(1 - \frac{V_{OUT}}{V_{IN}}\right)$$

A reasonable starting point for setting ripple current is $\Delta I_L = 320\text{mA}$ (40% of 800mA). For output voltages above 2.0V, when efficiency at light load condition is important, the minimum recommended inductor is 2.2 μH . For optimum voltage-positioning load transients, choose an inductor with DC series resistance below 150m Ω . For higher efficiency at heavy loads (above 200mA), or minimal load regulation (but some transient overshoot), the resistance should be kept below 100m Ω . The DC current rating of the inductor should be at least equal to the maximum load current plus half the ripple current to prevent core saturation. Thus, a 960mA rated inductor should be enough for most applications (800mA+160mA).

Input Capacitor Selection

The input capacitor reduces the surge current drawn from the input and switching noise from the device. The input capacitor impedance at the switching frequency shall be less than input source impedance to prevent high frequency switching current passing to the input. In continuous mode, the source current of the main switch is a square wave of duty cycle V_{OUT}/V_{IN} . To prevent large voltage transients, a low ESR input capacitor sized for the maximum RMS current must be used. The maximum RMS capacitor current is given by:

$$I_{RMS} \approx I_{OMAX} \frac{[V_{OUT}(V_{IN} - V_{OUT})]^{0.5}}{V_{IN}}$$

This formula has a maximum at $V_{IN} = 2V_{OUT}$, where $I_{RMS} = I_{OUT}/2$. This simple worst-case condition is commonly used for design because even significant deviations do not offer much relief. Ceramic capacitors with X5R or X7R dielectrics are recommended due to their low ESR and high ripple current.

Output Capacitor Selection

The output capacitor is required to keep the output voltage ripple small and to ensure regulation loop stability. The output capacitor must have low impedance at the switching frequency. Ceramic capacitors with X5R or X7R dielectrics are recommended due to their low ESR and high ripple current. The output ripple ΔV_{OUT} is determined by:



$$\Delta V_{OUT} \leq \frac{V_{OUT} \times (V_{IN} - V_{OUT})}{V_{IN} \times f_{OSC} \times L} \times \left(ESR + \frac{1}{8 \times f_{OSC} \times C_2} \right)$$

Layout Considerations

When laying out the printed circuit board, the following checklist should be used to ensure proper operation of the A7208. Check the following in your layout:

1. The power traces, consisting of the GND trace, the SW trace and the V_{IN} trace should be kept short, direct and wide.
2. Does the V_{FB} pin connect directly to the feedback resistors? The resistive divider R1/R2 must be connected between the (+) plate of C_{OUT} and ground.
3. Does the (+) plate of C_{IN} connect to V_{IN} as closely as possible? This capacitor provides the AC current to the internal power MOSFETS.
4. Keep the switching node, SW, away from the sensitive V_{FB} node.
5. Keep the (-) plates of C_{IN} and C_{OUT} as close as possible.



PACKAGE INFORMATION

Dimension in PSOP8 Package (Unit: mm)

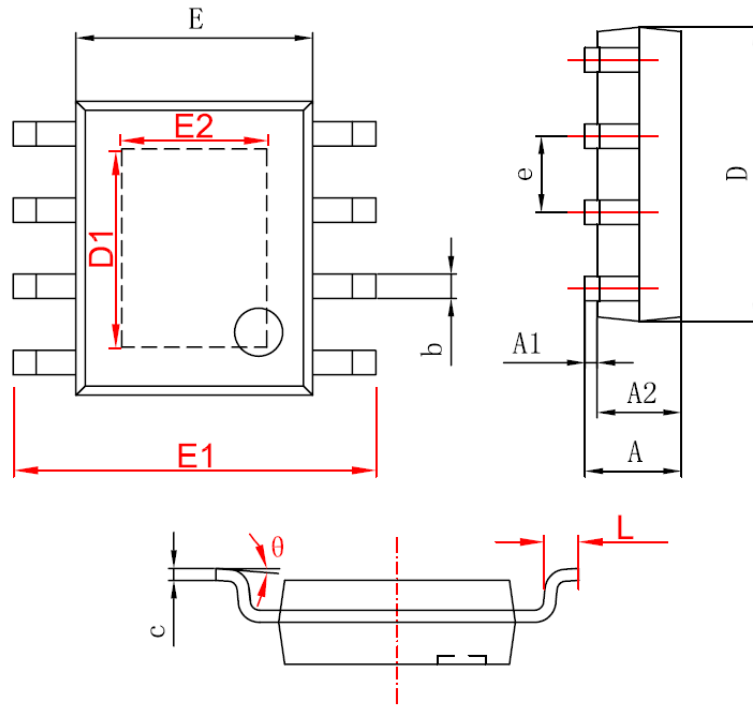

Symbol	Min	Max
A	1.350	1.750
A1	0.050	0.150
A2	1.350	1.550
b	0.330	0.510
c	0.170	0.250
D	4.700	5.100
D1	3.202	3.402
E	3.800	4.000
E1	5.800	6.200
E2	2.313	2.513
e	1.270(BSC)	
L	0.400	1.270
θ	0°	8°



IMPORTANT NOTICE

AiT Semiconductor Inc. (AiT) reserves the right to make changes to any its product, specifications, to discontinue any integrated circuit product or service without notice, and advises its customers to obtain the latest version of relevant information to verify, before placing orders, that the information being relied on is current.

AiT Semiconductor Inc.'s integrated circuit products are not designed, intended, authorized, or warranted to be suitable for use in life support applications, devices or systems or other critical applications. Use of AiT products in such applications is understood to be fully at the risk of the customer. As used herein may involve potential risks of death, personal injury, or severe property, or environmental damage. In order to minimize risks associated with the customer's applications, the customer should provide adequate design and operating safeguards.

AiT Semiconductor Inc. assumes to no liability to customer product design or application support. AiT warrants the performance of its products of the specifications applicable at the time of sale.