



Preliminary

A7302A/B

Sub 1GHz ASK / FSK Transmitter

Document Title

Sub 1GHz ASK/FSK Transmitter

Revision History

<u>Rev. No.</u>	<u>History</u>	<u>Issue Date</u>	<u>Remark</u>
0.0	Initial issue	Aug. 18th, 2006	Preliminary
0.1	Add SPI description	Jun. 7 th , 2007	Preliminary
0.2	Logo Changed.	Oct. 18 th , 2007	Preliminary
0.3	Bug Fix	Feb. 19 th , 2008	Preliminary
0.4	Bug Fix	Feb. 21 th , 2008	Preliminary
0.5	Bug Fix	Apr. 24 th , 2008	Preliminary
0.6	Fig 9.3.2 SPI Chart Fix Add top marking info., reflow profile, tape reel dimension Chapter 10. Application Circuit Fix	Oct. 09. 2008	Preliminary
0.7	Modify ordering information, Top marking information	Nov. 04. 2008	Preliminary

Important Notice:

AMICCOM reserves the right to make changes to its products or to discontinue any integrated circuit product or service without notice. AMICCOM integrated circuit products are not designed, intended, authorized, or warranted to be suitable for use in life-support applications, devices or systems or other critical applications. Use of AMICCOM products in such applications is understood to be fully at the risk of the customer.

Table of Content

1. General Description	3
2. Typical Applications	3
3. Features	3
4. Pin Configuration	3
5. Pin Description.....	3
6. Block Diagram	3
7. Specification	4
8. Maximum Ratings	5
9. Circuit Description.....	6
9.1 Hardware-pin Control Mode.....	6
9.1.1 Hardware-pin Control Interface	6
9.1.2 Frequency Setting.....	6
9.2 SPI Control Mode.....	6
9.2.1 SPI Control interface	6
9.3 SPI Format	8
9.3.1 SPI Format.....	8
9.3.2 Timing Chart: LSB First.....	8
9.3.3 Timing Specification	8
9.4 Register	9
9.4.1 Register 0:.....	9
9.4.2 Register 1.....	9
9.5 Operation Mode	11
9.5.1 OFF Mode	11
9.5.2 Active Mode.....	11
9.5.3 Standby Mode	11
9.5.4 Time Sequences.....	11
9.6. Power Control Configuration.....	12
9.6.1 In Hardware Mode	12
9.6.2 SPI Mode	12
9.6.3 Ultra Low Power Configuration	12
10. Application Circuit	13
11. Ordering Information.....	13
12. Package Information	1
12.1 DFN-10 Outline Dimensions	1
13. Top Marking Information	2
14. Reflow Profile.....	4
15. Tape Reel Information.....	5

Important Notice:

AMICCOM reserves the right to make changes to its products or to discontinue any integrated circuit product or service without notice. AMICCOM integrated circuit products are not designed, intended, authorized, or warranted to be suitable for



Preliminary

A7302A/B

Sub 1GHz ASK / FSK Transmitter

use in life-support applications, devices or systems or other critical applications. Use of AMICCOM products in such applications is understood to be fully at the risk of the customer.

1. General Description

The A7302 is a crystal based single chip ASK/FSK transmitter for operation in frequency band 300~450MHz/850~928MHz. This crystal based architecture provide better performance such as frequency stability, faster frequency settling and easier for mass production,

2. Typical Applications

- Remote Control.
- Wireless Sensor.
- Tire Pressure Monitoring.
- Garage Door Openers.
- Wireless Toy.

3. Features

- Small DFN10 package.
- A7302A for 300~450MHz. A7302B for 850~950MHz
- Very simple control interface: Only 1~ 2 signal is possible.
- Fully integrated PLL, VCO, PA, and Crystal oscillator.
- 2.2V ~3.6V operation.
- -40~85/125 °C operation.
- Power down mode.
- Fast on crystal oscillator.
- Typical low cost 4/12/13.56/16MHz crystal.
- 13mA@ +10dBm 433MHz / 11.5mA @ +5dBm 868Mhz
- Build in RF power control.
- Data rate up to 20Kbps

4. Pin Configuration

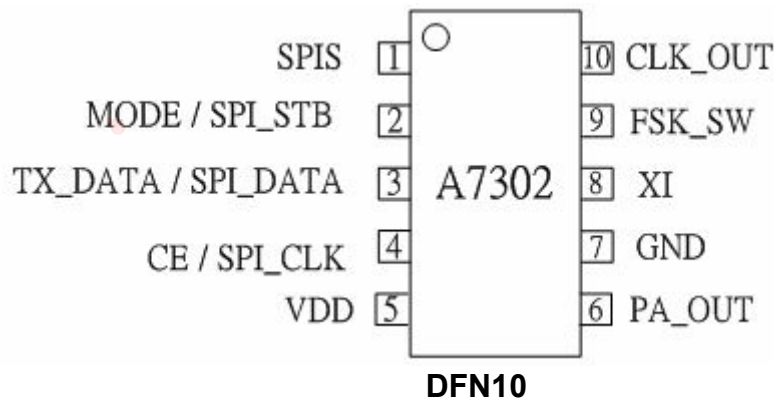

Important Notice:



A7302A/B

Preliminary

Sub 1GHz ASK / FSK Transmitter

~~AMICCOM reserves the right to make changes to its products or to discontinue any integrated circuit product or service without notice. AMICCOM integrated circuit products are not designed, intended, authorized, or warranted to be suitable for use in life-support applications, devices or systems or other critical applications. Use of AMICCOM products in such applications is understood to be fully at the risk of the customer.~~

5. Pin Description

Pin No.	Pin Name	Function
1	SPIS	SPI selection. Connect to GND: Pin 2,3,4 will be configured as MODE, TX_DATA and CE. Connect to VDD : Pin 2,3,4 will be configured as SPI_STB, SPI_DATA and SPI_CLK.
2	MODE	Chip mode selection Connect to GND: 433MHz band, ASK mode. Connect 120K Ω to GND: 315MHz band, ASK mode. Connect 240K Ω to GND: 315MHz band, FSK mode. Connect to VDD: 433MHz band, FSK mode.
	SPI_STB	SPI strobe.
3	TX_DATA	Transmitted data input.
	SPI_DATA/TX_DATA	SPI data input.
4	CE	Chip enables. Logic high sets the chip into active mode.
	SPI_CLK	SPI clock.
5	VDD	Power supply.
6	PA_OUT	Power amplifier output.
7	GND	Ground.
8	XI	Crystal oscillator port
9	FSK_SW	FSK modulation switch.
10	CLK_OUT	Divided clock output. Fclk=Fxtal/16 or /4. Default /4. Could be changed by SPI.

6. Block Diagram

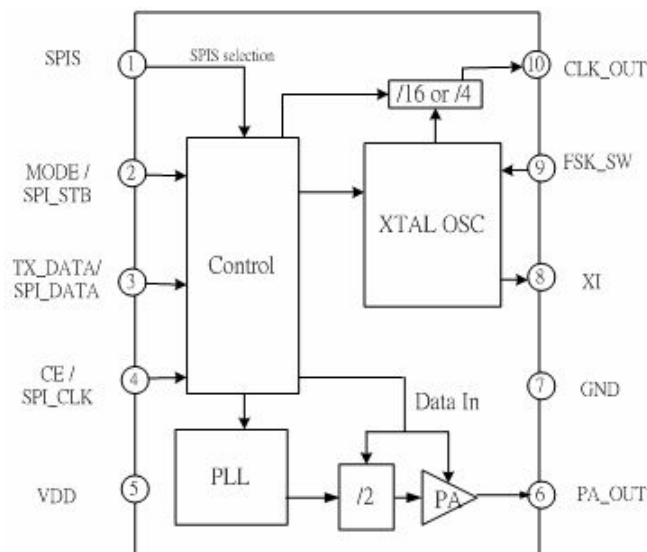



7. Specification

General Test Condition: Ta = 25°C, VDD=3.0V

Parameter	Description	Min.	Typ.	Max.	Unit
General					
Operating Temperature		-40		85/125	°C
Supply Voltage		2.2	3.0	3.6	V
Crystal Frequency		4	13.56	16	MHz
Crystal Tolerance			50		ppm
Crystal Start-up time			0.8	1.2	ms
PLL Setting Time			1	1.8	ms

General Test Condition: Ta = 25°C, VDD=3.0V

Parameter	Description	Min.	Typ.	Max.	Unit
RF Specification and DC Consumption for A7302A					
Frequency Range		300		450	MHz
Output Power	TXP=00, with Inductor		10		dBm
	TXP=01, with Inductor		7		
	TXP=10, with Inductor		2		
	TXP=11, with Inductor		0		
	TXP=11, Use Resistor 2K		-10		
	TXP=11, Use Resistor 4.3K		-20		
	TXP=11, Use Resistor 10K		-30		
	TXP=11, Open Inductor		-40		
Phase Noise	Offset=100KHz		-80		dBc/Hz
	Offset=1MHz		-100		
Reference Spur			-50		dBc
Current Consumption	TXP=00, with Inductor		13		mA
	TXP=01, with Inductor		11.5		
	TXP=10, with Inductor		9		
	TXP=11, with Inductor		8		
	TXP=11, Use Resistor 2K		7.3		
	TXP=11, Use Resistor 4.3K		5.5		
	TXP=11, Use Resistor 10K		5.1		
	TXP=11, Open Inductor		4.8		
	CE=high, 50% duty cycle Power		8		
	CE=low, Ta=25°C,		20		nA

General Test Condition: Ta = 25°C, VDD=3.0V

Parameter	Description	Min.	Typ.	Max.	Unit
RF Specification and DC Consumption for A7302B					
Frequency Range		850		950	MHz
Output Power	TXP=00		5		dBm
	TXP=01		2		
	TXP=10		-1		
	TXP=11		-5		
	TXP=11, Use Resistor 1K		-15		

	TXP=11, Use Resistor 2K		-20		
	TXP=11, Use Resistor 4.3K		-30		
	TXP=11, Open Inductor		-40		
Phase Noise	Offset=100KHz		-80		dBc/Hz
	Offset=1MHz		-100		
Reference Spur			-40		dBc
Current Consumption	TXP=00, with Inductor		11.5		mA
	TXP=01, with Inductor		8.8		
	TXP=10, with Inductor		7.8		
	TXP=11, with Inductor		7.5		
	TXP=11, Use Resistor 1K		7.0		
	TXP=11, Use Resistor 2K		6.3		
	TXP=11, Use Resistor 4.3K		5.5		
	TXP=11, Open Inductor		4.8		
	CE=high, 50% duty cycle Power		8		mA
	CE=low, Ta=25°C,		20		nA

General Test Condition: Ta = 25°C, VDD=3.0V

Parameter	Description	Min.	Typ.	Max.	Unit
modulation Specification					
ASK Data Rate	ASK			64	Kbps
ASK ON/OFF ration	433MHz		90		dB
	866MHz		60		dB
FSK Data Rate	FSK			20	Kbps

8. Maximum Ratings

Characteristic	Pin name/symbol	Rating	Unit
Power supply voltage	All VDD	5.0	V
Power dissipation	PD	TBD	Mw
Input pin voltage		5	V
Storage temperature range	T _{stg}	-55~150	°C

9. Circuit Description

The A7302 is a highly integrated ASK/FSK transmitter featuring very low power consumption, flexible user interface and compact DFN10 package. A built-in control sequence automatically brings A7201 into operation after a few settings, making this chip easy to use and power saving.

A7302 supports both hardware-pin and SPI controlled interface. User can use pin1 (SPIS) to select mode.

9.1 Hardware-pin Control Mode

For general-purpose, 13.56MHz crystal-based applications, user can pull down pin1 (SPIS) to set chip to hardware-pin control mode.

9.1.1 Hardware-pin Control Interface

Control interface as Figure 9.1.1. In Hardware-pin mode, user can select ASK/FSK by resistor and on/off by CE pin

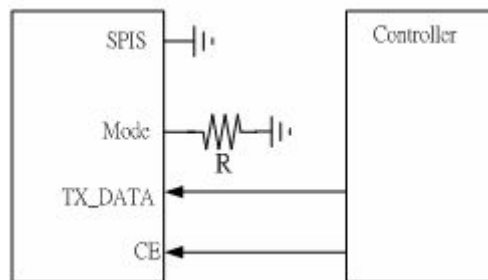

Figure 9.1.1

MODE	<p>Chip mode selection</p> <p>Connect to GND: 433MHz band, ASK mode.</p> <p>Connect 120KΩ to GND: 315MHz band, ASK mode.</p> <p>Connect 240KΩ to GND: 315MHz band, FSK mode.</p> <p>Connect to VDD: 433MHz band, FSK mode.</p>
------	--

9.1.2 Frequency Setting

In Hardware-ware mode

$$A7302A \rightarrow f_{RF} = f_{Crystal} \times 64 / 2$$

$$A7302B \rightarrow f_{RF} = f_{Crystal} \times 64$$

9.2 SPI Control Mode

User can control this chip through SPI to get more flexible configuration, such as multi RF channel, 4/12/16MHz crystal, Power control, and clock out definition...etc.

9.2.1 SPI Control interface

Control interface as Figure 9.2.1. .

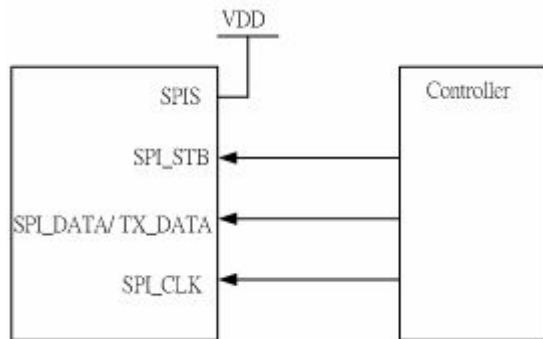

Figure 9.2.1

In SPI Control Mode, SPI_DATA and TX_DATA use same pin. They select by SPI_STB Control Timing Chart

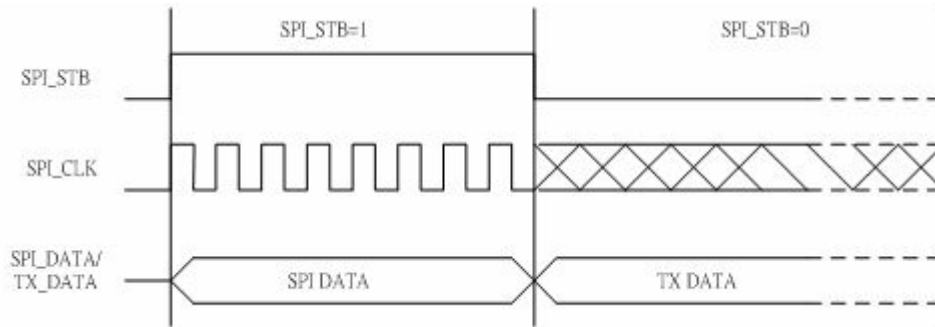

Figure 9.2.2

9.3 SPI Format

9.3.1 SPI Format

One Package (16 Bits)															Register Select	
Data															1	0
15	14	13	12	11	10	9	8	7	6	5	4	3	2	1	0	

9.3.2 Timing Chart: LSB First

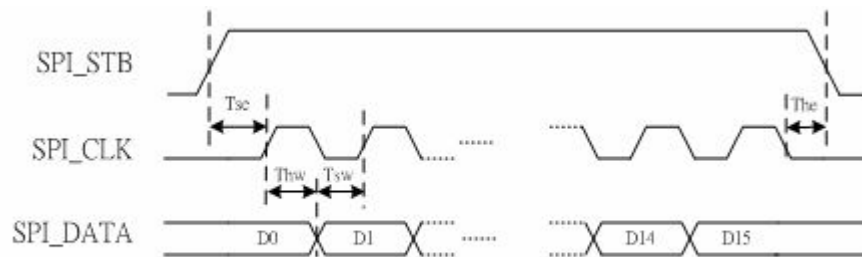

9.3.3 Timing Specification

Parameter	Description	Min	Max	Unit
F_c	SPI Clock Frequency		4	MHz
T_{sc}	SPI_STB Setup Time	50		ns
T_{he}	SPI_STB Hold Time	50		ns
T_{sw}	SPI_DATA Setup Time	50		ns
T_{hw}	SPI_DATA Hold Time	50		ns

9.4 Register

9.4.1 Register 0: Used for RF/Crystal frequency setting.

Bit	15	14	13	12	11	10	9	8	7	6	5	4	3	2	1	0
Name	R1	R0	NB7	NB6	NB5	NB4	NB3	NB2	NB1	NB0	NA3	NA2	NA1	NA0	0	0
Reset	0	0	0	1	0	0	0	0	1	1	1	1	0	1		

Note: (1) D0, D1 is address bit.

(2) All bits will be reset to default value after VIO powered on.

N [11:0]: Binary format of PLL N counter. Used for RF frequency channel control.
N= (16XNB) +NA. NB=46~144, NA=0~15.

$$A7302A \rightarrow f_{RF} = f_{crystal} \times N / R / 2$$

$$A7302B \rightarrow f_{RF} = f_{crystal} \times N / R$$

R [1:0]: Crystal reference frequency selection.
[00]: R=5 for 4MHz crystal.
[01]: R=15 for 12MHz crystal.
[10]: R=16 for 13.56MHz crystal.
[11]: R=20 for 16MHz crystal.

9.4.2 Register 1: Used for comment and parameters setting.

Bit	15	14	13	12	11	10	9	8	7	6	5	4	3	2	1	0
Name	NA	NA	NA	NA	NA	NA	TXP1	TXP0	CKS	ECK	STBY	BAND	FSK_ASK	CE	1	0
Reset	0	0	0	0	0	0	0	0	1	1	0	1	0	0		

Note: (1) D0, D1 is address bit.

(2) All bits will be reset to default value after VIO powered on.

CE: Chip enables. 0: go to sleep mode. 1: go to active mode.

FSK_ASK: FSK_ASK selection. 0: ASK. 1: FSK.

BAND: RF band selection.

A7302A → 0: 315MHz band, 1: 433MHz band.

A7302B → 0: 868MHz band, 1: 915MHz band.

STBY: Standby mode selection. Chip will keep crystal oscillator running. 0: normal mode. 1: standby mode.

ECK: Output clock (pin 10 CLK_OUT) enable. 0: disable. 1: enable.

CKS: Output clock (pin 10 CLK_OUT) divider ratio selection. 0: crystal frequency /16. 1: crystal frequency /4.

TXP [1:0]: Transmitter output RF power control.

A7302A		
TXP[1:0]	Typical RF power (dBm)	Typical TX current (mA)
[00]	+10	13
[01]	+7	11
[10]	+4	9
[11]	+1	8

A7302B		
TXP[1:0]	Typical RF power (dBm)	Typical TX current (mA)
[00]	+5	11.5
[01]	+2	8.8
[10]	-1	7.8
[11]	-5	7.5

9.5 Operation Mode

9.5.1 OFF Mode

In OFF Mode, Chip will turn off all power

Control Interface	Control Way
Hardware-pin Control Mode	CE = 0
SPI Control Mode	Register 1 -> Bit2 (CE) = 0 Register 1 -> Bit5 (STBY) = 0

9.5.2 Active Mode

Control Interface	Control Way
Hardware-pin Control Mode	CE = 1
SPI Control Mode	Register 1 -> Bit2 (CE) = 1 Register 1 -> Bit5 (STBY) = 0

9.5.3 Standby Mode

In standby mode, chip will keep crystal oscillator running and only turn of RF power.

Control Interface	Control Way
Hardware-pin Control Mode	No Support
SPI Control Mode	Register 1 -> Bit2 (CE) = 0 Register 1 -> Bit5 (STBY) = 1

9.5.4 Time Sequences

OFF Mode -> Active Mode -> OFF

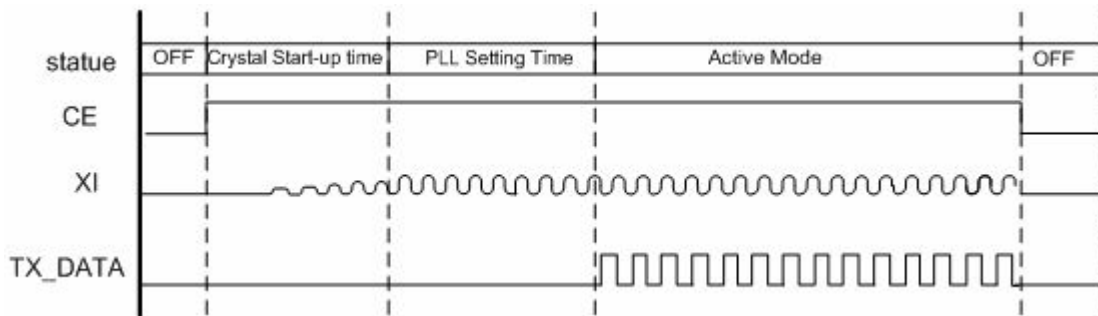

Standby mode -> Active Mode -> OFF

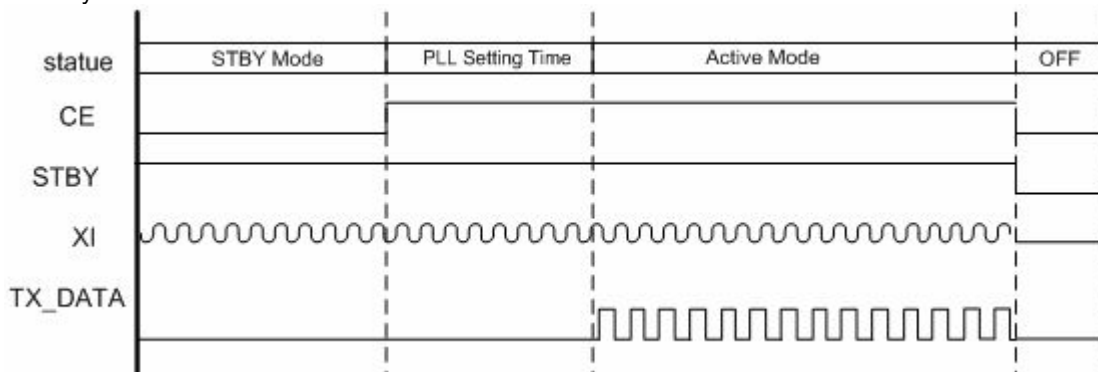

9.6. Power Control Configuration

9.6.1 In Hardware Mode

In Hardware mode, User can use external resistor (R4) to achieve saving current.

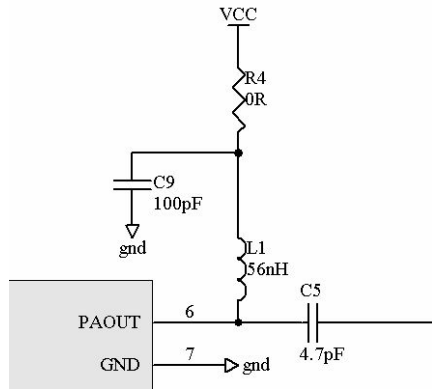

9.6.2 SPI Mode

In SPI Mode, MCU can control power by SPI. Using Bit9 and Bit 8 of register 1 can have 4 steps power level to achieve saving current.

A7302A		
TXP[1:0]	Typical RF power (dBm)	Typical TX current (mA)
[00]	+10	13
[01]	+7	11
[10]	+4	9
[11]	+1	8

A7302B		
TXP[1:0]	Typical RF power (dBm)	Typical TX current (mA)
[00]	+5	11.5
[01]	+2	8.8
[10]	-1	7.8
[11]	-5	7.5

9.6.3 Ultra Low Power Configuration

If you want to have ultra low power to achieve current saving, you can use resistor to substitute inductor (L1).

A7302A TXP[1:0]=11		
Resistor	Typical RF power (dBm)	Typical TX current (mA)
2K	-10	7.3
4.3K	-20	5.5
10K	-30	5.1
Open	-40	4.8

A7302B TXP[1:0]=11		
TXP[1:0]	Typical RF power (dBm)	Typical TX current (mA)
1K	-15	7.0
2K	-20	6.3
4.3K	-30	5.5
Open	-40	4.8

10. Application Circuit

A7302A (L1=56nH, C5=4.7pF) · A7302B (L1=12nH, C5=2.2pF)

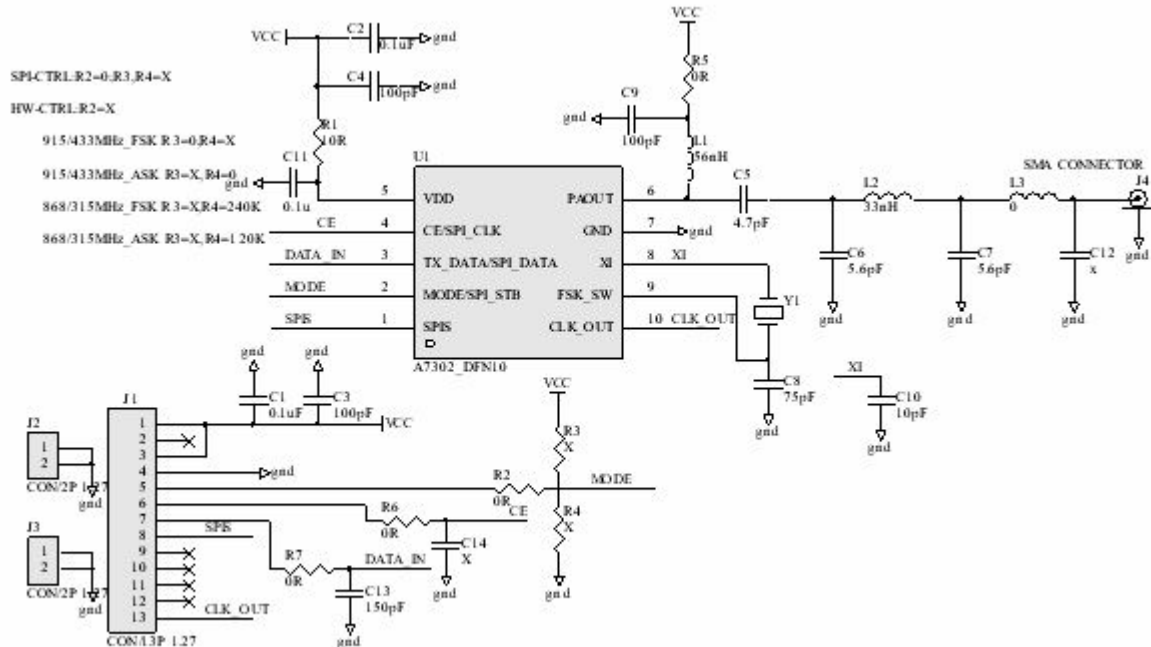

11. Ordering Information

Part No.	Package	Units Per Reel / Tube
A73C02ADF/Q	DFN10, Tape & Reel, Pb free	3000pcs
A73C02ADF	DFN10, Tube, Pb free	121pcs
A73C02BDF/Q	DFN10, Tape & Reel, Pb free	3000pcs
A73C02BDF	DFN10, Tube, Pb free	121pcs

12. Package Information

12.1 DFN-10 Outline Dimensions

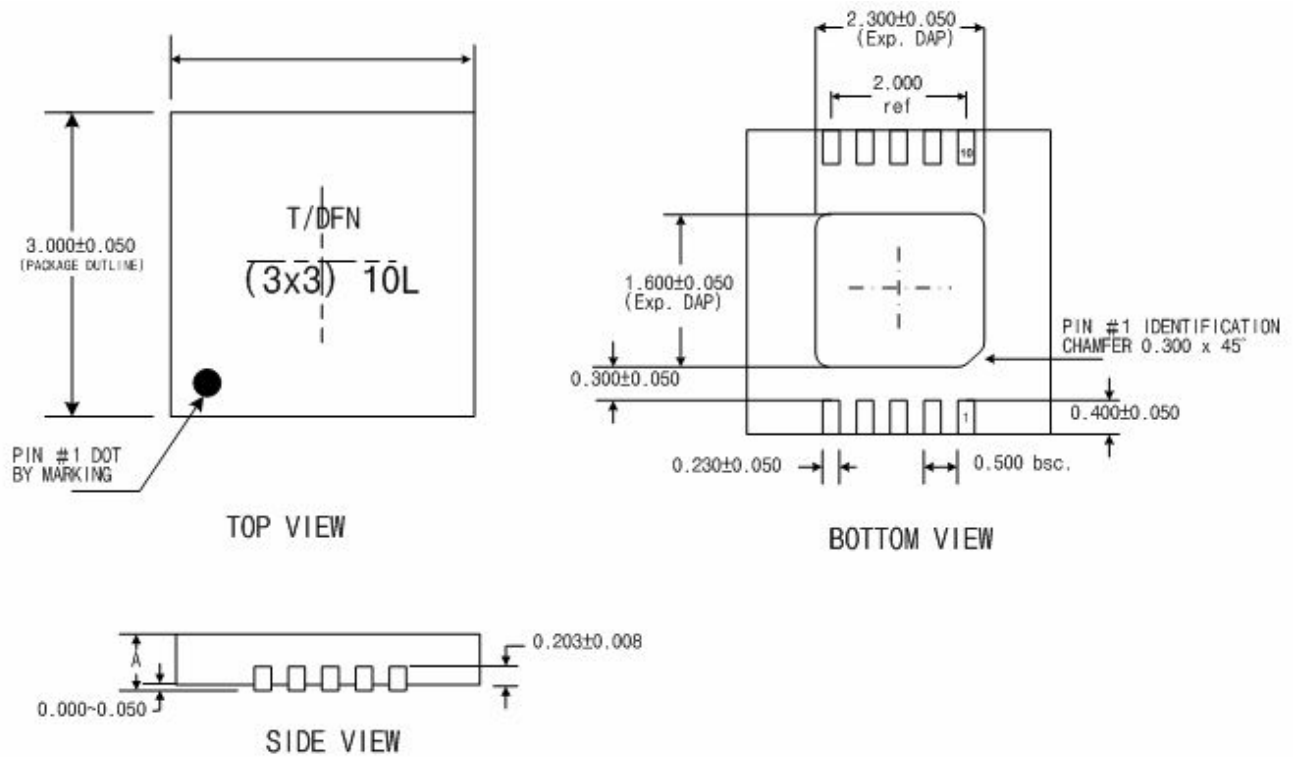

13. Top Marking Information

A73C02ADF

- Part No. : **A73C02ADF**
- Pin Count : **10**
- Package Type : **DFN**
- Dimension : **3*3 mm**
- Mark Method : **Laser Mark**
- Character Type : **Arial**

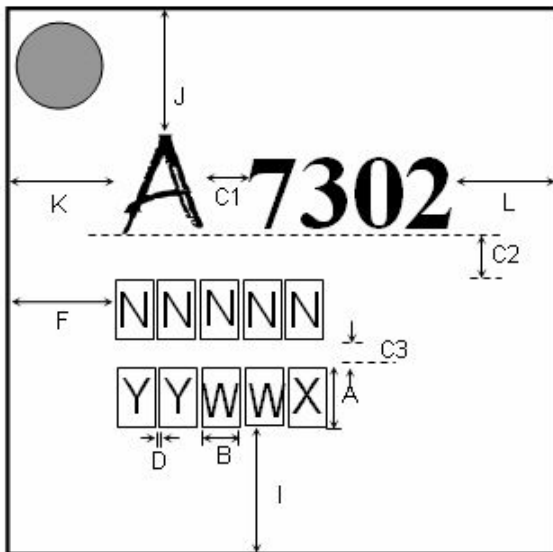

❖ CHARACTER SIZE : (Unit in mm)

A : 0.55
 B : 0.30
 C1 : 0.25 C2 : 0.3 C3 : 0.2
 D : 0.03
 A1 : 0.75
 B2 : 0.7

I=J
 F=K=L

YYWW : DATECODE
 X : PKG HOUSE ID
 NNNNN : LOT NO.
 (The last 5 characters,
 no decimals)

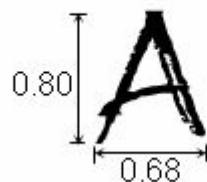

A73C02BDF

- Part No. : **A73C02BDF**
- Pin Count : **10**
- Package Type : **DFN**
- Dimension : **3*3 mm**
- Mark Method : **Laser Mark**
- Character Type : **Arial**

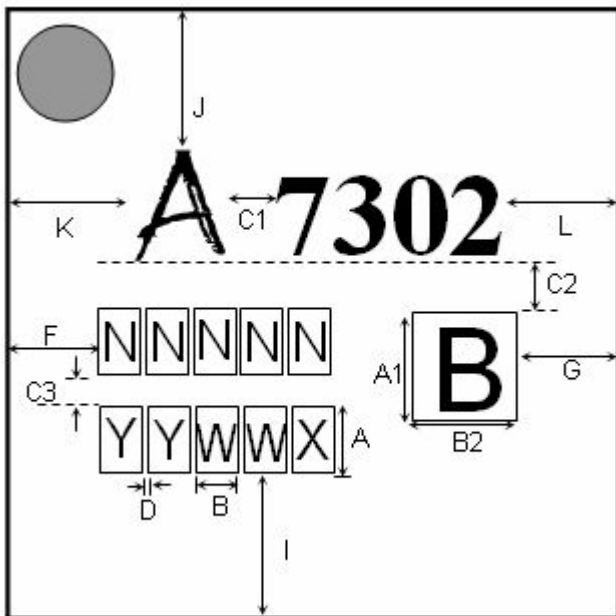

❖ CHARACTER SIZE : (Unit in mm)

A : 0.55
 B : 0.30
 C1 : 0.25 C2 : 0.3 C3 : 0.2
 D : 0.03
 A1 : 0.75
 B2 : 0.7

F=G
 I=J
 K=L

Y Y W W

: DATECODE

X

: PKG HOUSE ID

N N N N N

: LOT NO.

(The last 5 characters,
no decimals)

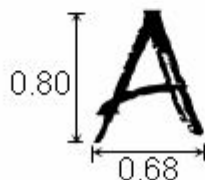

14. Reflow Profile

LEAD FREE (GREEN) PROFILE :

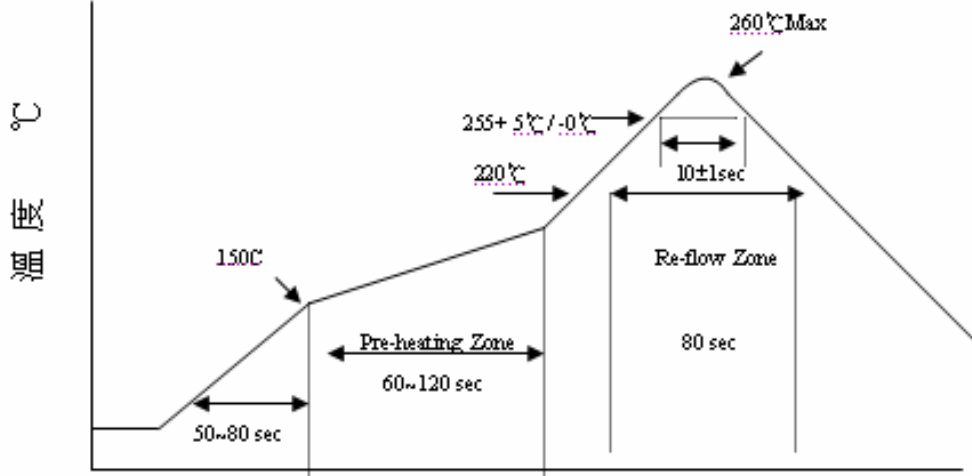

Actual Measurement Graph

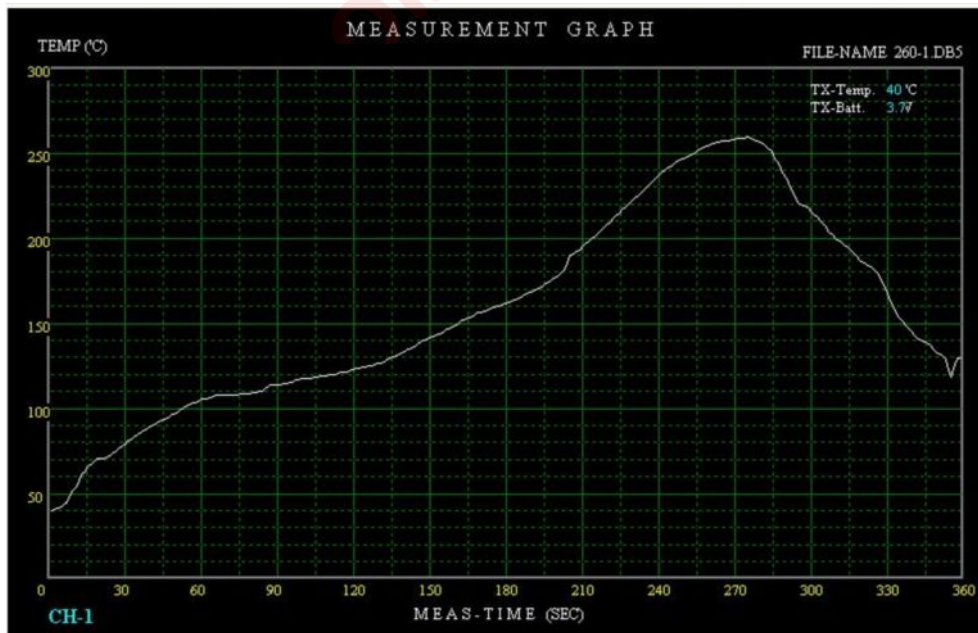

15. Tape Reel Information

Cover / Carrier Tape Dimension

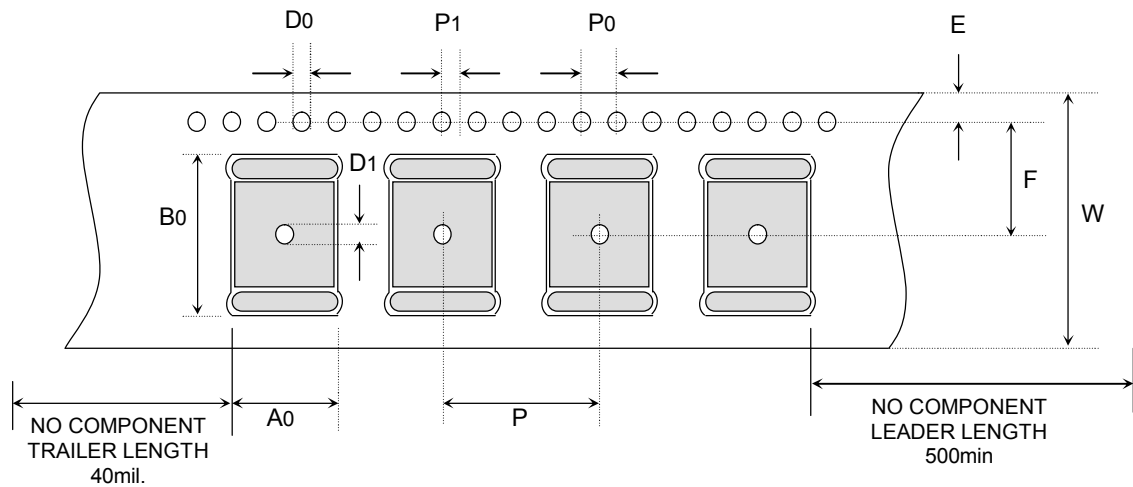

11 EA IC

60cm±4cm

TYPE	P	A0	B0	P0	P1	D0	D1	E	F	W
20 QFN 4*4	8	4.35	4.35	4.0	2.0	1.5	1.5	1.75	5.5	12
24 QFN 4*4	8	4.4	4.4	4.0	2.0	1.5	1.5	1.75	5.5	12
32 QFN 5*5	8	5.25	5.25	4.0	2.0	1.5	1.5	1.75	5.5	12
48 QFN 7*7	12	7.25	7.25	4.0	2.0	1.5	1.5	1.75	7.5	16
DFN-10	4	3.2	3.2	4.0	2.0	1.5	-	1.75	1.9	8
20 SSOP	12	8.2	7.5	4.0	2.0	1.5	1.5	1.75	7.5	16
24 SSOP	12	8.2	8.8	4.0	2.0	1.5	1.5	1.75	7.5	16
28 SSOP (150mil)	8	6	10	4.0	2.0	1.5	1.5	1.75	7.5	16

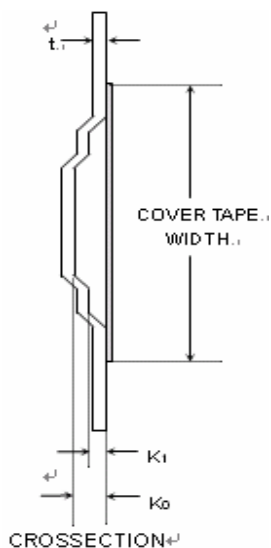

TYPE	K0	K1	t
20 QFN (4X4)	1.1	-	0.3
24 QFN (4X4)	1.4	-	0.3
32 QFN (5X5)	1.1	-	0.3
48 QFN (7X7)	1.1	-	0.3
DFN-10	0.75	-	0.25
20 SSOP	2.5	-	0.3
24 SSOP	2.1	-	0.3
28 SSOP (150mil)	2.5	-	0.3

COVER TAPE WIDTH
9.2
9.2
9.2
13.3
8
13.3
13.3
12.5

Unit : mm

REEL DIMENSIONS

UNIT IN mm

TYPE	G	N	T	M	D	K	L	R
20 QFN(4X4) 24 QFN(4X4) 32 QFN(5X5) DFN-10	12.8+0.6/- 0.4	100 REF	18.2(MAX)	1.75±0.25	13.0+0.5/- 0.2	2.0±0.5	330+ 0.00/-1.0	20.2
48 QFN(7X7)	16.8+0.6/- 0.4	100 REF	22.2(MAX)	1.75±0.25	13.0+0.5/- 0.2	2.0±0.5	330+ 0.00/-1.0	20.2
28 SSOP (150mil)	20.4+0.6/- 0.4	100 REF	25(MAX)	1.75±0.25	13.0+0.5/- 0.2	2.0±0.5	330+ 0.00/-1.0	20.2
20 SSOP 24 SSOP	16.4+2.0/- 0.0	100 REF	22.4(MAX)	1.75±0.25	13.0+0.2/- 0.2	1.9±0.4	330+ 0.00/-1.0	20.2

