



DESCRIPTION

The A7406 is a current mode monolithic buck switching regulator. Operating with an input range of 4.7V~40V, the A7406 delivers 600mA of continuous output current with two integrated N-Channel MOSFETs. The internal synchronous power switches provide high efficiency without the use of an external Schottky diode. At light loads, the regulator operates in low frequency to maintain high efficiency and low output ripple. Current mode control provides tight load transient response and cycle-by-cycle current limit.

The A7406 guarantees robustness with short-circuit protection, thermal protection, current run-away protection, and input under voltage lockout.

The A7406 is available in SOT-26 package.

ORDERING INFORMATION

Package Type	Part Number	
SOT-26	E6	A7406E6R
		A7406E6VR
Note	V: Halogen free Package R: Tape & Reel	
AiT provides all RoHS products Suffix " V " means Halogen free Package		

FEATURES

- 4.7V to 40V operating input range
- 600mA output current
- Up to 93% efficiency
- High efficiency (>78%) at light load
- Internal Soft-Start
- 2MHz switching frequency
- Input under voltage lockout
- Current run-away protection
- Short circuit protection
- Thermal protection
- Available in SOT-26 Package

APPLICATION

- Distributed Power Systems
- Automotive Systems
- High Voltage Power Conversion
- Industrial Power Systems
- Battery Powered Systems

TYPICAL APPLICATION

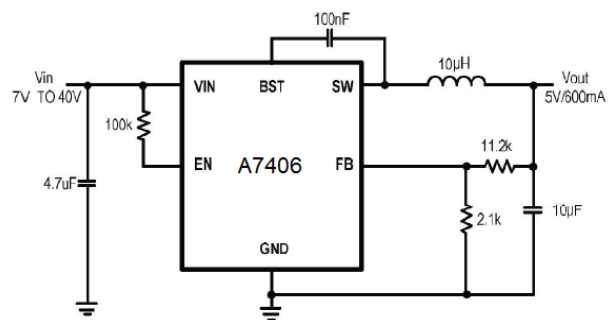



PIN DESCRIPTION

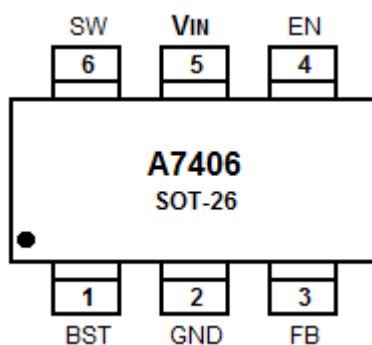

Top View

Pin #	Symbol	Function
1	BST	Bootstrap pin for top switch. A 0.1uF or larger capacitor should be connected between this pin and the SW pin to supply current to the top switch and top switch driver.
2	GND	Ground
3	FB	Output feedback pin. FB senses the output voltage and is regulated by the control loop to 800mV. Connect a resistive divider at FB.
4	EN	Drive EN pin high to turn on the regulator and low to turn off the regulator.
5	V _{IN}	Input voltage pin. V _{IN} supplies power to the IC. Connect a 4.7V to 40V supply to V _{IN} and bypass V _{IN} to GND with a suitably large capacitor to eliminate noise on the input to the IC.
6	SW	SW is the switching node that supplies power to the output. Connect the output LC filter from SW to the output load.



ABSOLUTE MAXIMUM RATINGS

V _{IN} , EN, SW Pin	-0.3V~44V
BST Pin	SW-0.3V~SW+5V
All other Pins	-0.3V~6V
Junction Temperature ^{NOTE1,2}	150°C
Lead Temperature	260°C
Storage Temperature	- 65°C~+150°C
Recommended Operating Conditions	
V _{IN} , Input Voltage	4.7V~40V
V _{OUT} , Output Voltage	0.8V~37V
Operating Junction Temperature	-40°C~125°C
Thermal resistance ^{NOTE3}	
θ _{JA}	220°C/W
θ _{JC}	130°C/W

Stress beyond above listed "Absolute Maximum Ratings" may lead permanent damage to the device. These are stress ratings only and operations of the device at these or any other conditions beyond those indicated in the operational sections of the specifications are not implied. Exposure to absolute maximum rating conditions for extended periods may affect device reliability.

NOTE1: The A7406 guarantees robust performance from -40°C to 150°C junction temperature. The junction temperature range specification is assured by design, characterization and correlation with statistical process controls.

NOTE2: The A7406 includes thermal protection that is intended to protect the device in overload conditions. Thermal protection is active when junction temperature exceeds the maximum operating junction temperature. Continuous operation over the specified absolute maximum operating junction temperature may damage the device.

NOTE3: Measured on JESD51-7, 4-layer PCB.



ELECTRICAL CHARACTERISTICS

$V_{IN}=24V$, $T_A=25^{\circ}C$, unless otherwise stated.

Parameter	Symbol	Conditions	Min.	Typ.	Max.	Unit
V_{IN} Undervoltage Lockout Thershold	V_{IN_MIN}	V_{IN} falling		4.2		V
V_{IN} Undervoltage Lockout Hysteresis	$V_{IN_MIN_HYST}$	V_{IN} rising		160		mV
Shutdown Supply Current	I_{SD}	$V_{EN}=0V$		0.07	1	μA
Supply Current	I_Q	$V_{EN}=5V$, $V_{FB}=1V$		50		μA
Feedback Voltage	V_{FB}	$4.7V < V_{IN} < 40V$	776	800	824	mV
Top Switch Resistance	$R_{DS(ON)T}$			500		m Ω
Bottom Switch Resistance	$R_{DS(ON)B}$			220		m Ω
Top Switch Leakage Current	I_{LEAK_TOP}	$V_{IN}=40V$, $V_{EN}=0V$, $V_{SW}=0V$			1	μA
Bottom Switch Leakage Current	I_{LEAK_BOT}	$V_{IN}=V_{SW}=40V$, $V_{EN}=0V$			1	μA
Top Switch Current Limit	I_{LIM_TOP}	Minimum Duty Cycle		1		A
Switch Frequency	f_{SW}			2		MHz
Minimum On Time	T_{ON_MIN}			80		ns
Minimum Off Time	T_{OFF_MIN}	$V_{FB}=0V$		100		ns
EN Shut Down Threshold Voltage	V_{EN_TH}	V_{EN} falling, $FB=0V$		1.2		V
EN Shut Down Hysteresis	V_{EN_HYST}	V_{EN} rising, $FB=0V$		40		mV
Thermal Shutdown	T_{TSD}			135		$^{\circ}C$
Thermal Shutdown Hysteresis	T_{TSD_HYST}			15		$^{\circ}C$



TYPICAL PERFORMANCE CHARACTERISTICS

$V_{IN}=12V$, $V_{OUT}=5V$, $L=10\mu H$, $C_{OUT}=10\mu F$, $T_A=+25^\circ C$, unless otherwise noted

1. Steady State Test

$V_{IN}=12V$, $V_{OUT}=5V$, $I_{OUT}=600mA$

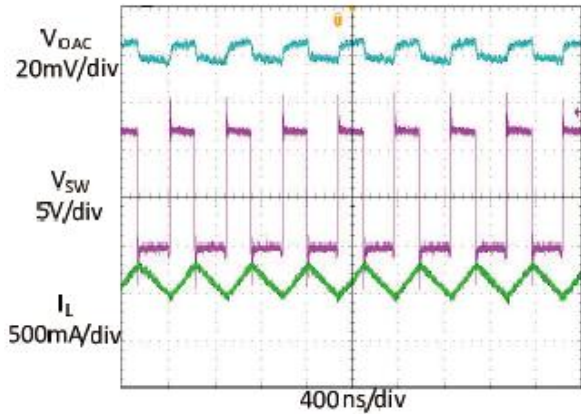

2. Startup through Enable

$V_{IN}=12V$, $V_{OUT}=5V$, $I_{OUT}=600mA$ (Resistive load)

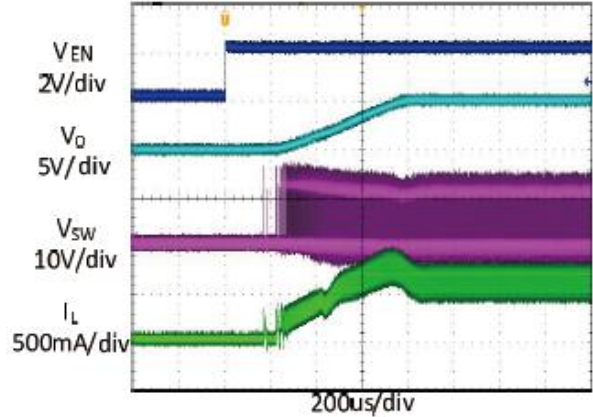

3. Shutdown through Enable

$V_{IN}=12V$, $V_{OUT}=5V$, $I_{OUT}=600mA$ (Resistive load)

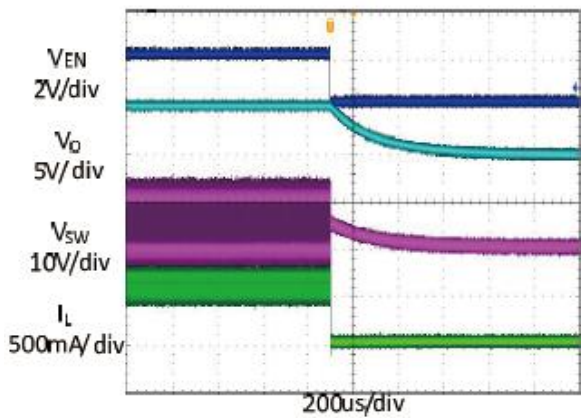

4. Heavy Load Operation

600mA LOAD

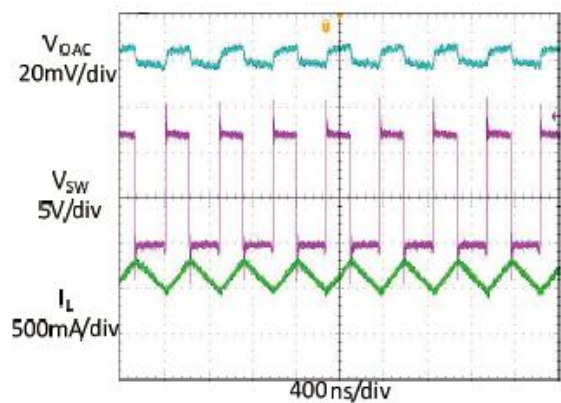

5. Medium Load Operation

300mA LOAD

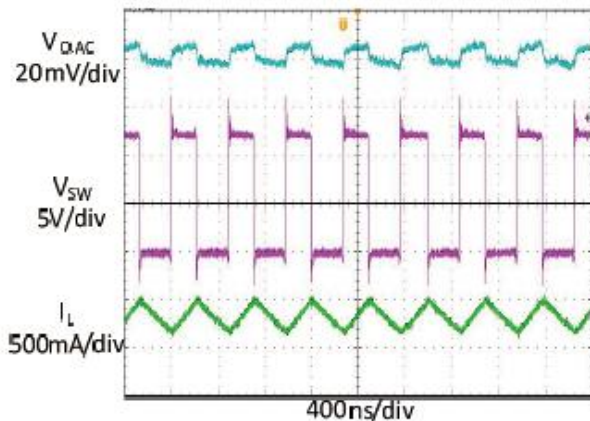

6. Light Load Operation

0A LOAD

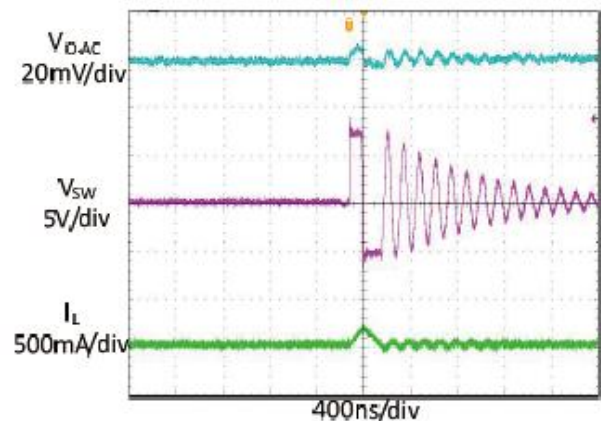



7. Short Circuit Protection
 $V_{IN}=12V$, $V_{OUT}=5V$, $I_{OUT}=600mA$ -Short

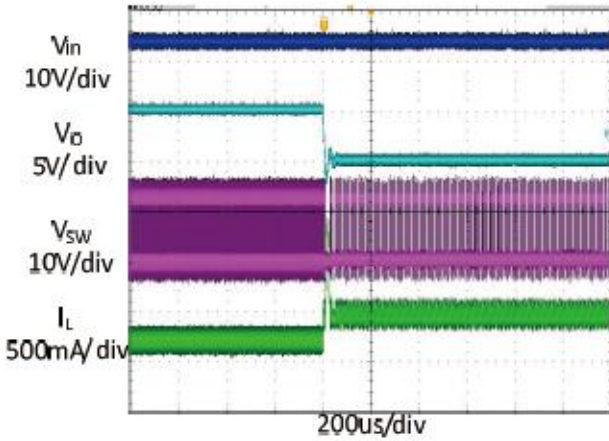

8. Short Circuit Recovery
 $V_{IN}=12V$, $V_{OUT}=5V$, I_{OUT} =Short-600mA

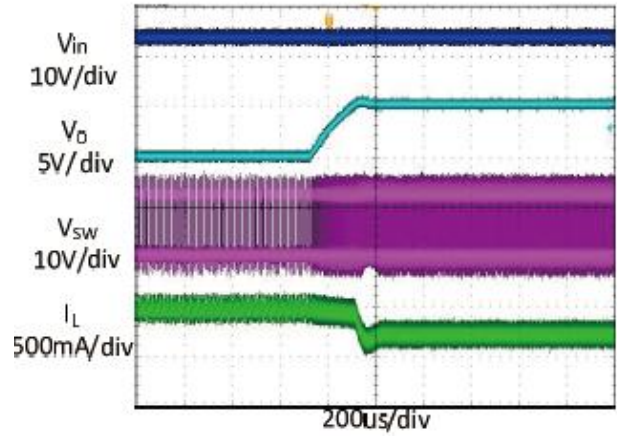

9. Load Transient
300mA LOAD \rightarrow 600mA LOAD \rightarrow 300mA LOAD

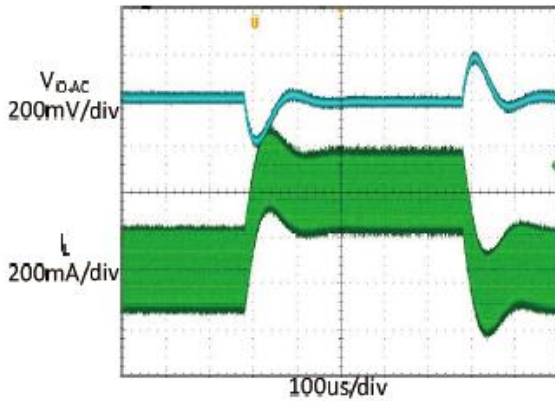

10. Efficiency @ $V_{OUT}=5V$

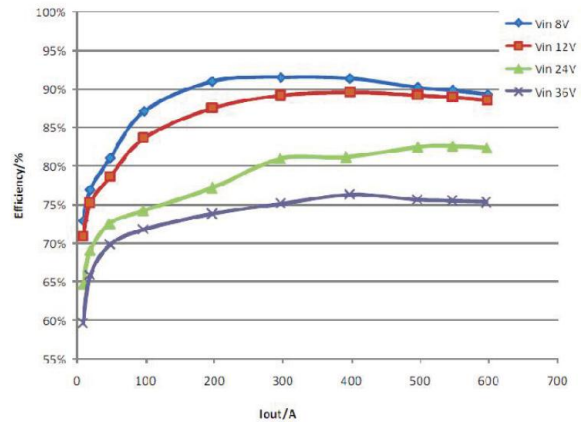



BLOCK DIAGRAM

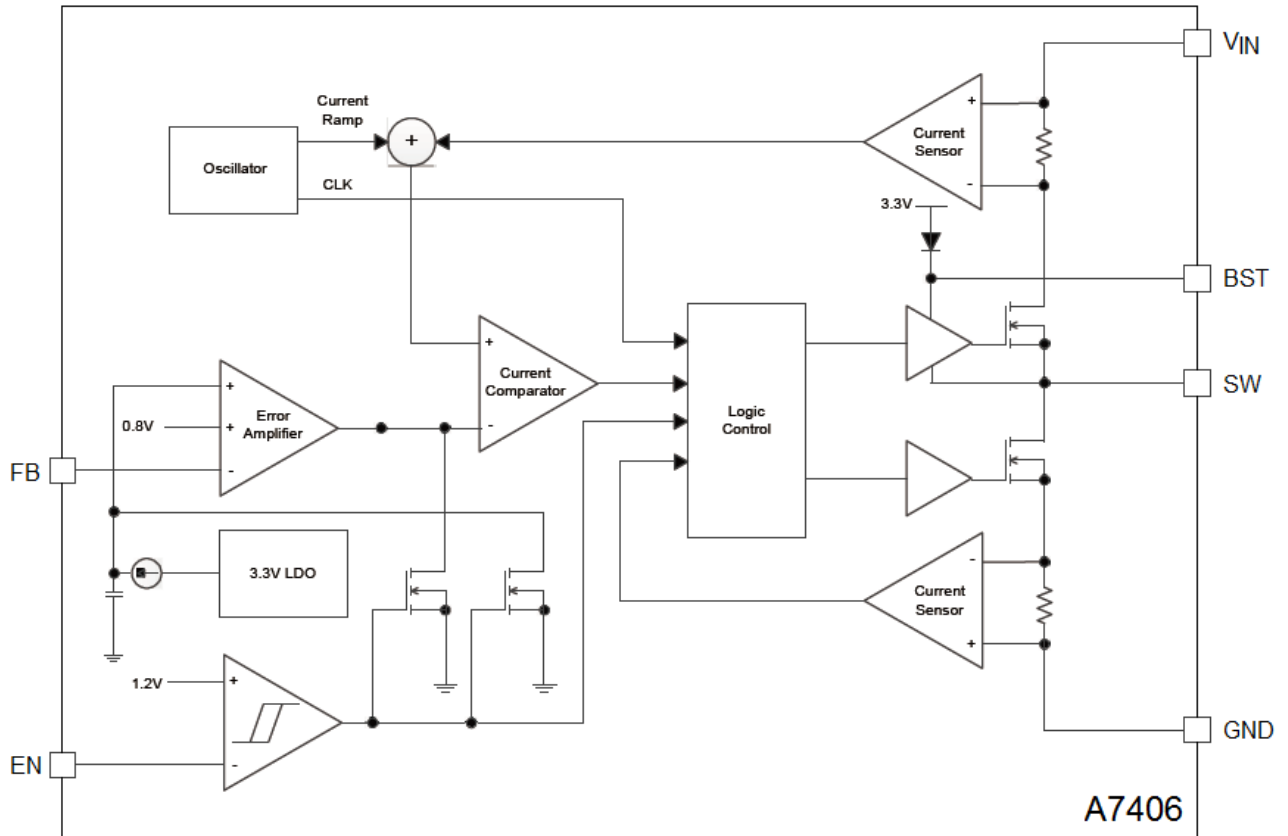



DETAILED INFORMATION

FUNCTIONAL DESCRIPTION

The A7406 is a synchronous, current-mode, step-down regulator. It regulates input voltages from 4.7V to 40V down to an output voltage as low as 0.8V, and is capable of supplying up to 600mA of load current.

Current-Mode Control

The A7406 utilizes current-mode control to regulate the output voltage. The output voltage is measured at the FB pin through a resistive voltage divider and the error is amplified by the internal transconductance error amplifier.

Output of the internal error amplifier is compared with the switch current measured internally to control the output current.

PFM Mode

The A7406 operates in PFM mode at light load. In PFM mode, switch frequency decreases when load current drops to boost power efficiency at light load by reducing switch-loss, while switch frequency increases when load current rises, minimizing output voltage ripples.

Shut-Down Mode

The A7406 shuts down when voltage at EN pin is below 1.2V. The entire regulator is off and the supply current consumed by the A7406 drops below 0.1uA when voltage at EN pin is below 0.3V.

Power Switch

N-Channel MOSFET switches are integrated on the A7406 to down convert the input voltage to the regulated output voltage. Since the top MOSFET needs a gate voltage great than the input voltage, a boost capacitor connected between BST and SW pins is required to drive the gate of the top switch. The boost capacitor is charged by the internal 3.3V rail when SW is low.

V_{IN} Under-Voltage Protection

A resistive divider can be connected between V_{IN} and ground, with the central tap connected to EN, so that when V_{IN} drops to the pre-set value, EN drops below 1.2V to trigger input under voltage lockout protection.



Output Current Run-Away Protection

At start-up, due to the high voltage at input and low voltage at output, current inertia of the output inductance can be easily built up, resulting in a large start-up output current. A valley current limit is designed in the A7406 so that only when output current drops below the valley current limit can the top power switch be turned on. By such control mechanism, the output current at start-up is well controlled.

Output Short Protection

When output is shorted to ground, output current rapidly reaches its peak current limit and the top power switch is turned off. Right after the top power switch is turned off, the bottom power switch is turned on and stay on until the output current falls below the valley current limit. When output current is below the valley current limit, the top power switch will be turned on again and if the output short is still present, the top power switch is turned off when the peak current limit is reached and the bottom power switch is turned on. This cycle goes on until the output short is removed and the regulator comes into normal operation again.

Thermal Protection

When the temperature of the A7406 rises above 135°C, it is forced into thermal shut-down. Only when core temperature drops below 120°C can the regulator becomes active again.

PCB Layout Note

1. Place the input decoupling capacitor as close to A7406 (V_{IN} pin and PGND) as possible to eliminate noise at the input pin.
2. Put the feedback trace as far away from the inductor and noisy power traces as possible.
3. The ground plane on the PCB should be as large as possible for better heat dissipation.



REFERENCE DESIGN

Reference 1:

V_{IN} : 5.1V~40V

V_{OUT} : 3.3V

I_{OUT} : 0~600mA

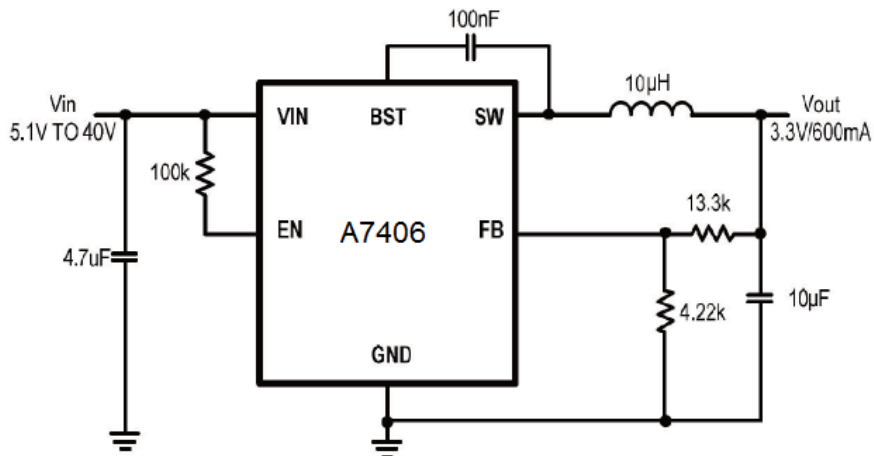

Reference 2:

V_{IN} : 7V~40V

V_{OUT} : 5V

I_{OUT} : 0~600mA

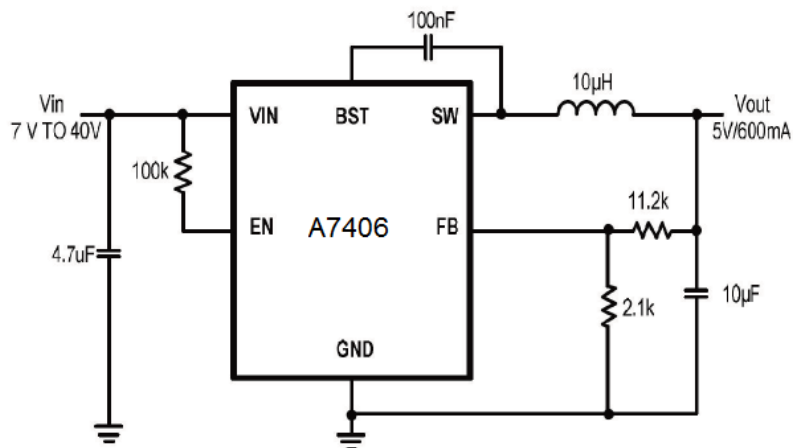



PACKAGE INFORMATION

Dimension in SOT-26 Package (Unit: mm)

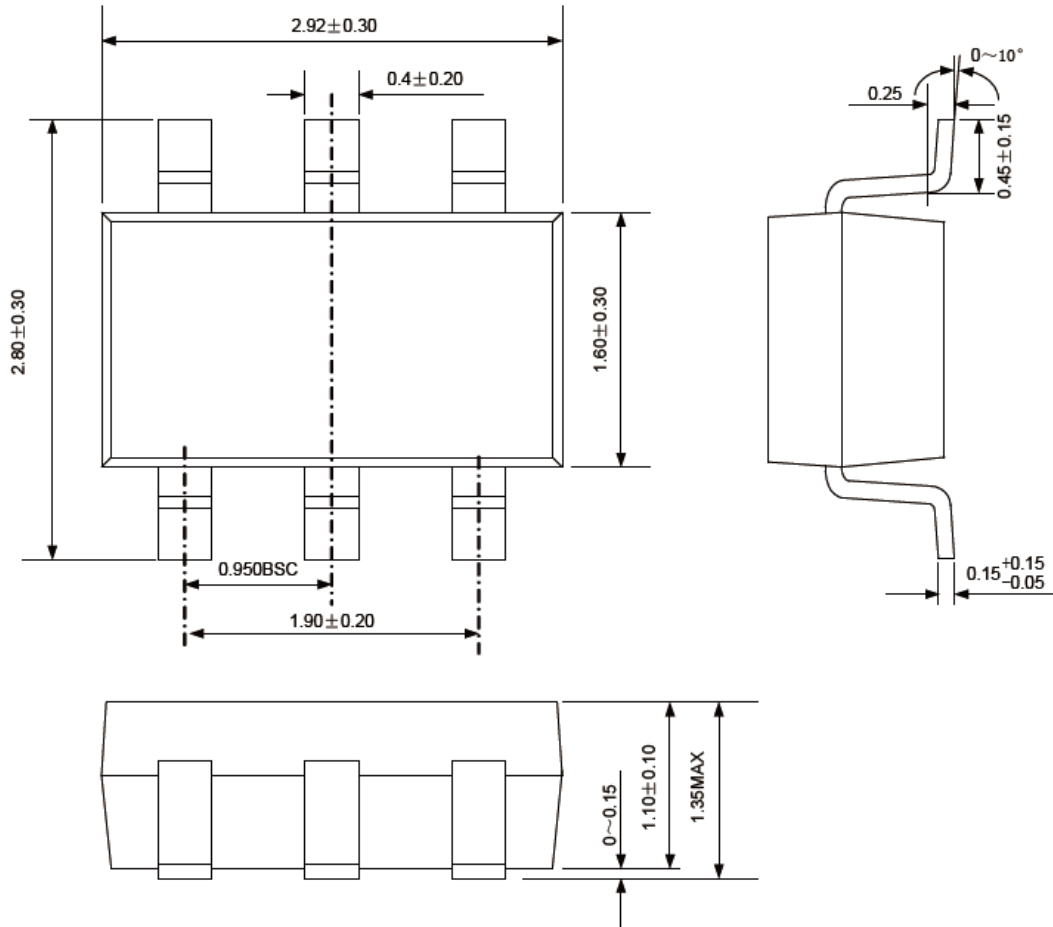



IMPORTANT NOTICE

AiT Semiconductor Inc. (AiT) reserves the right to make changes to any its product, specifications, to discontinue any integrated circuit product or service without notice, and advises its customers to obtain the latest version of relevant information to verify, before placing orders, that the information being relied on is current.

AiT Semiconductor Inc.'s integrated circuit products are not designed, intended, authorized, or warranted to be suitable for use in life support applications, devices or systems or other critical applications. Use of AiT products in such applications is understood to be fully at the risk of the customer. As used herein may involve potential risks of death, personal injury, or severe property, or environmental damage. In order to minimize risks associated with the customer's applications, the customer should provide adequate design and operating safeguards.

AiT Semiconductor Inc. assumes to no liability to customer product design or application support. AiT warrants the performance of its products of the specifications applicable at the time of sale.