



DESCRIPTION

The A7596 series of regulators are monolithic integrated circuits that provide all the active functions for a step-down (buck) switching regulator, capable of driving a 3A load with excellent line and load regulation. These devices are available in fixed output voltage of 5V and adjustable output version.

The A7596 operates at a switching frequency of 150KHz thus allowing smaller sized filter components than what would be needed with lower frequency switching regulators.

Other features include a guaranteed $\pm 3\%$ tolerance on output voltage under specified input voltage and output load conditions, and $\pm 15\%$ on the oscillator frequency. External shutdown is included, featuring typically 100 μ A standby current.

The A7596 is available in TO-263-5 package.

ORDERING INFORMATION

Package Type	Part Number	
TO-263-5	S5	A7596S5R-XX
		A7596S5VR-XX
Note	XX: Output Voltage 050=5.0V; ADJ=Adjustable R: Tape & Reel V: Halogen free Package	
AiT provides all RoHS products Suffix " V " means Halogen free Package		

FEATURES

- 5V and adjustable output versions
- Adjustable version output voltage range 1.23V to 37V
- Input voltage range up to 40V
- Guaranteed 3A output current
- 150KHz fixed frequency internal oscillator
- Built-in thermal shutdown and current limit protection
- Available in TO-263-5 Package

APPLICATION

- Fixed voltage power supply for LCD monitor and LCD TV
- On-Card switching regulation
- Simple high efficiency Step-down regulator

TYPICAL APPLICATION

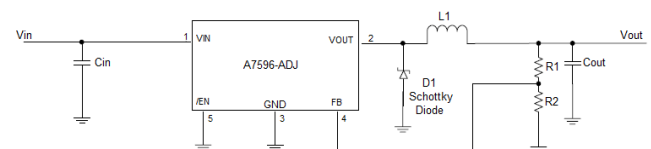

$V_{OUT} = 1.23V \times (1 + R1/R2)$, $C_{IN} = 100\mu F$, Aluminum Electrolytic;
 $C_{OUT} = 220\mu F$, 25V, Aluminum Electrolytic; D1 = Schottky, 5A/40V;
 $L1 = 33\mu H$

Figure 1 Adjustable Output Voltage

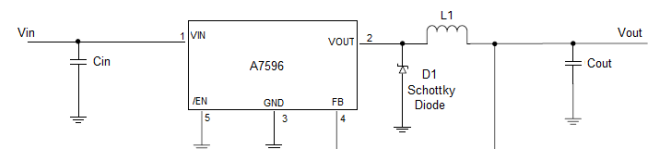

$C_{IN} = 100\mu F$, Aluminum Electrolytic; $C_{OUT} = 220\mu F$, 25V,
 Aluminum Electrolytic; D1 = Schottky, 5A/40V; $L1 = 33\mu H$

Figure 2 Fixed Voltage Regulator:



PIN DESCRIPTION

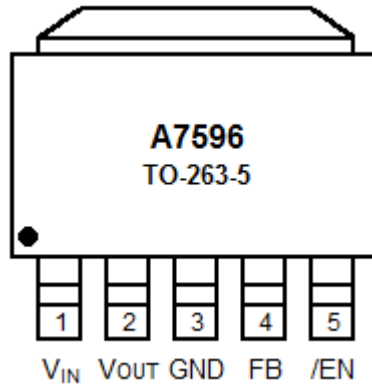

Top View

Pin #	Symbol	Function
1	V_{IN}	Input Voltage Pin
2	V_{OUT}	Output Voltage Pin
3	GND	Ground Pin
4	FB	Feed Back Pin
5	/EN	Enable Pin



ABSOLUTE MAXIMUM RATINGS

P_D , Power Dissipation	Internally Limited(W)
V_{IN} , Maximum Supply Voltage	45V
EN, EN Pin Input Voltage	$-0.3V < V < + V_{IN}$
θ_{JT} , Thermal resistance junction to Case	3.0°C /W
θ_{JA} , Thermal resistance junction to Ambient	36°C /W
T_J , Operating Junction Temperature Range	-40°C~+125°C
T_{STG} , Storage Temperature Range	-65°C~+150°C
ESD, Minimum EDS Rating	2KV
T_{LEAD} , Lead Soldering Temperature (Soldering, 10 sec)	260°C

Stress beyond above listed "Absolute Maximum Ratings" may lead permanent damage to the device. These are stress ratings only and operations of the device at these or any other conditions beyond those indicated in the operational sections of the specifications are not implied. Exposure to absolute maximum rating conditions for extended periods may affect device reliability.

RECOMMENDED OPERATING CONDITIONS

Parameter	Symbol	Min	Typ.	Max	Units
Input Voltage	V_{IN}			40	V
Peak Current	I_{PC}	3.4			A
Maximum Load Current	I_{OUT}		3		A
Junction Temperature	T_J	-40		150	°C



ELECTRICAL CHARACTERISTICS

These specifications apply $V_{IN} = 12V$ for 5.0V options, and $V_{IN} = 24V$ for Adj option, and the operating ambient temperatures $T_A = 25^{\circ}C$, Unless otherwise specified

Parameter	Symbol	Conditions	Min.	Typ.	Max.	Unit	
Output Voltage ^{NOTE1}	V_{OUT}	$4.5V \leq V_{IN} \leq 40V$ $0.2A \leq I_{OUT} \leq 2A, V_{OUT}=3V$	ADJ	1.193	1.230	1.267	V
		$7V \leq V_{IN} \leq 40V$ $0.2A \leq I_{OUT} \leq 3A$	5.0	4.850	5.000	5.150	
Efficiency	η	$V_{IN}=12V, I_{LOAD}=3A, V_{OUT}=3V$	ADJ		90		%
		$V_{IN}=12V, I_{LOAD}=3A$	5.0		80		
Feedback Bias Current	I_B	$V_{FB}=1.3V$ (Adjustable Version Only)		10	50	nA	
Saturation Voltage	V_{SAT}	$I_{OUT}=3A$ ^{NOTE1,2}		1.16	1.4	V	
Duty Cycle (ON)	DC	NOTE2		100		%	
Duty Cycle (OFF)	DC	NOTE3		0		%	
Oscillator Frequency	f_o	NOTE4	127	150	173	KHz	
Output Leakage Current	I_L	Output=0V ^{NOTE1, 3}			100	μA	
		Output=-0.9V ^{NOTE5}		2		mA	
Quiescent Current	I_Q	NOTE3		5		mA	
Standby Current	I_{STBY}	/EN Pin=5V		100	200	μA	
/EN Pin Input Level	V_{IH}	Low (ON)		1.3	0.6	V	
	V_{IL}	High (OFF)	2.0	1.4			
	I_H	$V_{LEVEL} = 2.5V$ (OFF)		5	15	μA	
	I_L	$V_{LEVEL} = 0.5V$ (ON)		0.02	5		

NOTE1: No diode, inductor or capacitor connected to output pin.

NOTE2: Feedback pin removed from output and connected to 0V to force the output transistor switch ON.

NOTE3: Feedback pin removed from output and connected to 5V and the ADJ version

NOTE4: The switching frequency is reduced when the second stage current limit is activated.

NOTE5: $V_{IN} = 40V$.



TYPICAL PERFORMANCE CHARACTERISTICS

25°C Unless Note

1. Switch Saturation Voltage

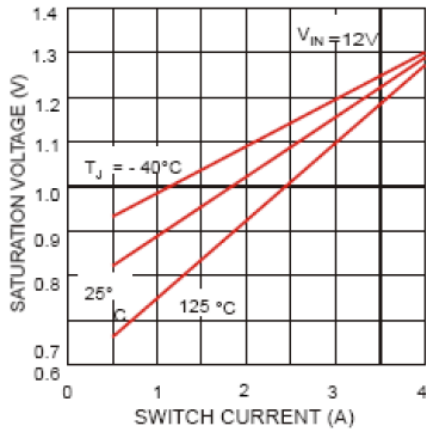

2. Switch Current Limit

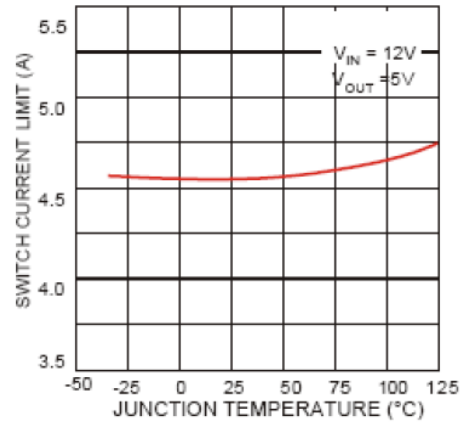

3. Dropout Voltage

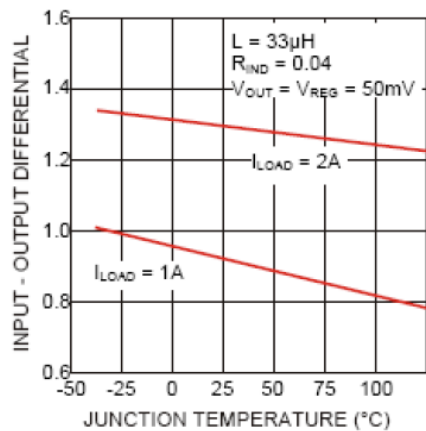

4. Operating Quiescent Current

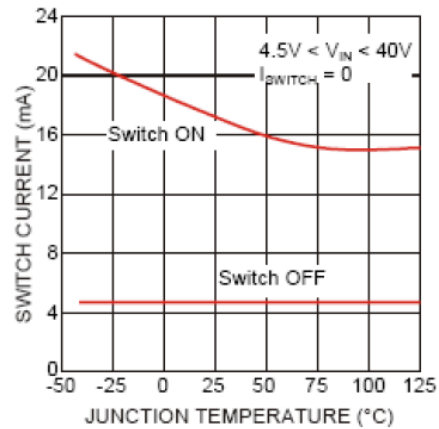

5. Shutdown Quiescent Current

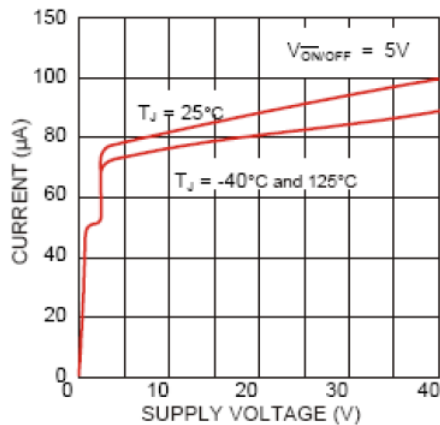

6. Minimum Operating Supply Voltage

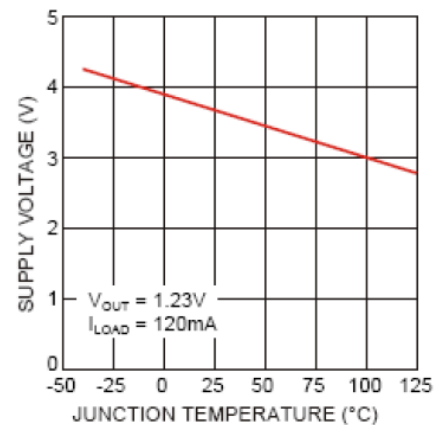



7. /EN Pin Current (Sinking)

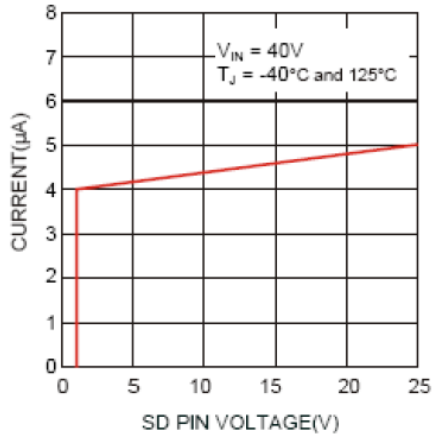

8. Switching Frequency

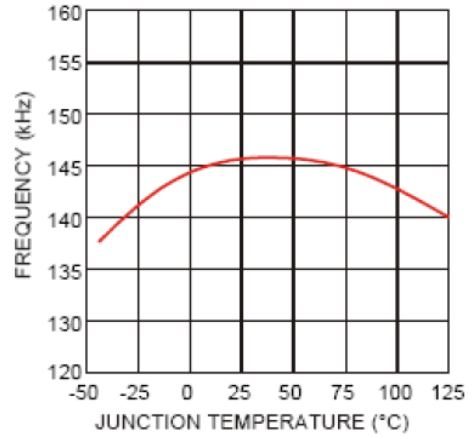



BLOCK DIAGRAM

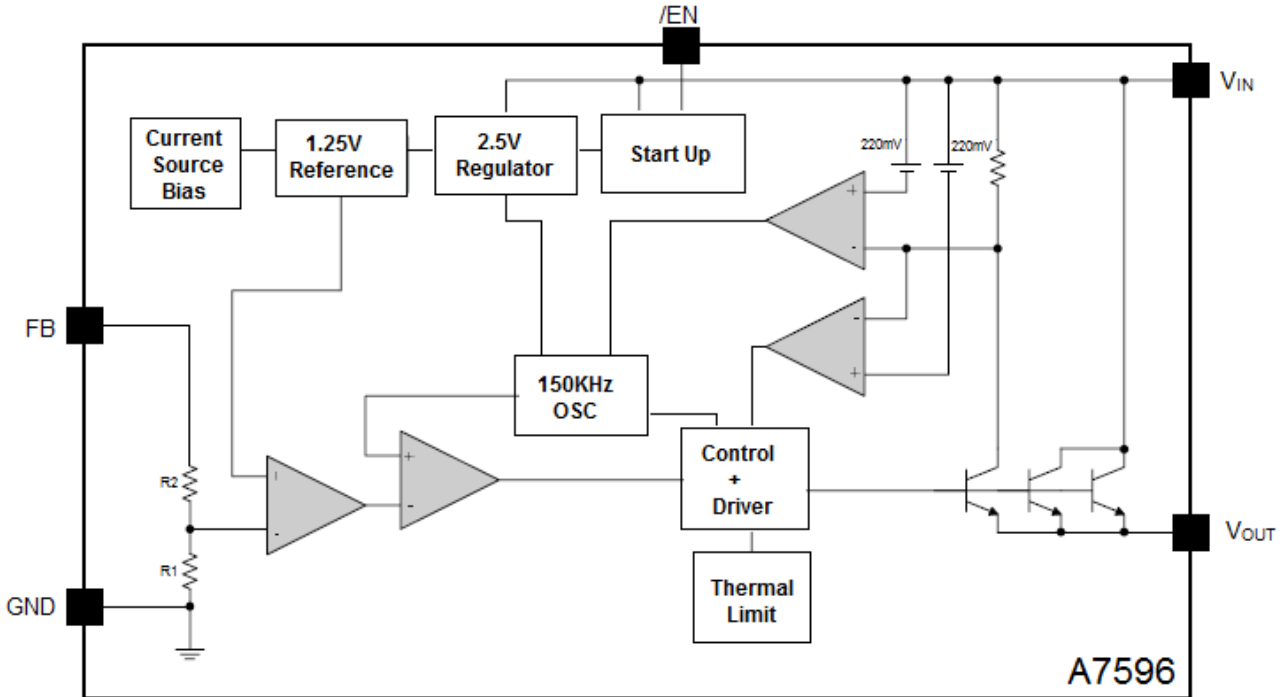



PACKAGE INFORMATION

Dimension in TO-263-5 (Unit: mm)

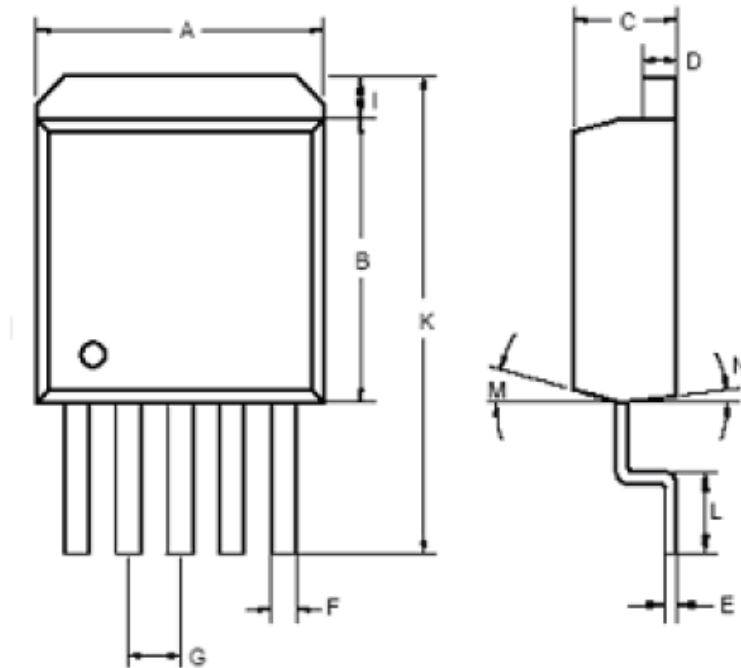

Symbol	Min	Max
A	10.030	10.670
B	8.250	9.170
C	4.340	4.590
D	1.140	1.400
E	0.330	0.432
F	0.737	0.889
G	1.570	1.830
I	12.700	1.650
K	14.600	16.130
L	2.290	2.790
M	7°	
N	3°	



IMPORTANT NOTICE

AiT Semiconductor Inc. (AiT) reserves the right to make changes to any its product, specifications, to discontinue any integrated circuit product or service without notice, and advises its customers to obtain the latest version of relevant information to verify, before placing orders, that the information being relied on is current.

AiT Semiconductor Inc.'s integrated circuit products are not designed, intended, authorized, or warranted to be suitable for use in life support applications, devices or systems or other critical applications. Use of AiT products in such applications is understood to be fully at the risk of the customer. As used herein may involve potential risks of death, personal injury, or severe property, or environmental damage. In order to minimize risks associated with the customer's applications, the customer should provide adequate design and operating safeguards.

AiT Semiconductor Inc. assumes to no liability to customer product design or application support. AiT warrants the performance of its products of the specifications applicable at the time of sale.