



## DESCRIPTION

The A7815 is available in TO220-3 package.

## ORDERING INFORMATION

Package Type	Part Number	
TO220-3 SPQ: 50pcs/Tube	T3	A7815T3U
		A7815T3VU
Note	V: Halogen free Package U: Tube	
AiT provides all RoHS products		

## FEATURES

- Maximum Output current  $I_{OM}$ : 1.5 A
- Output voltage  $V_o$ : 15V
- Continuous total dissipation  
 $P_D$ : 1.5 W ( $T_A = 25^\circ\text{C}$ )  
15 W ( $T_C = 25^\circ\text{C}$ )
- Available in TO220-3 Package

## TYPICAL APPLICATION

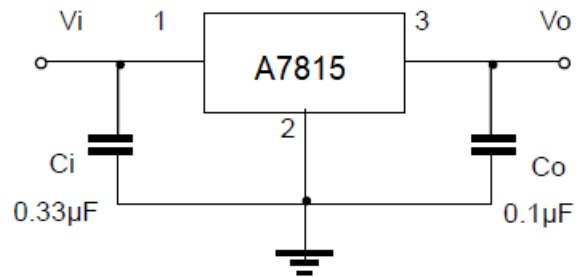

Note: Bypass capacitors are recommended for optimum stability and transient response and should be located as close as possible to the regulators.



## PIN DESCRIPTION

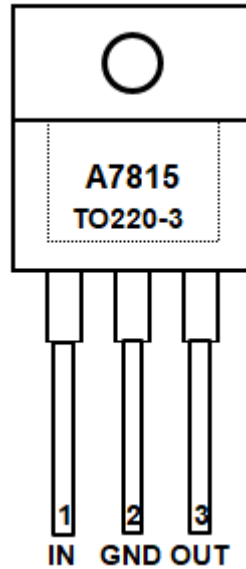

Top View

Pin #	Symbol	Function
1	$V_{IN}$	Input
2	GND	Ground
3	$V_{OUT}$	Output



## ABSOLUTE MAXIMUM RATINGS

Operating temperature range applies unless otherwise specified

$V_I$ , Input Voltage	35V
$R_{\theta JA}$ , Thermal Resistance from Junction to Ambient	83.3°C/W
$R_{\theta JC}$ , Thermal Resistance from Junction to Case	8.33°C/W
$T_{OPR}$ , Operating Junction Temperature Range	0°C ~ +150°C
$T_{STG}$ , Storage Temperature Range	-55°C ~ +150°C

Stress beyond above listed "Absolute Maximum Ratings" may lead permanent damage to the device. These are stress ratings only and operations of the device at these or any other conditions beyond those indicated in the operational sections of the specifications are not implied. Exposure to absolute maximum rating conditions for extended periods may affect device reliability.

## ELECTRICAL CHARACTERISTICS

$V_I=23V$ ,  $I_o=500mA$ ,  $C_I=0.33\mu F$ ,  $C_O=0.1\mu F$ , unless otherwise specified

Parameter	Symbol	Conditions	Min.	Typ.	Max.	Unit
Output Voltage	$V_o$	25°C	14.4	15	15.6	V
		17.5V ≤ $V_I$ ≤ 30V, $I_o=5mA-1A$ , $P \leq 15W$ 0~125°C	14.25	15	15.75	
Load Regulation	$\Delta V_o$	$I_o=5mA-1.5A$ 25°C	-	12	300	mV
		$I_o=250mA-750mA$ 25°C	-	4	150	
Line Regulation	$\Delta V_o$	17.5V ≤ $V_I$ ≤ 30V 25°C	-	12	300	mV
		20V ≤ $V_I$ ≤ 26V 25°C	-	3	150	
Quiescent Current	$I_q$	25°C	-	4.3	8	mA
Quiescent Current Change	$\Delta I_q$	17.5V ≤ $V_I$ ≤ 30V 0~125°C	-	-	1	mA
		5mA ≤ $I_o$ ≤ 1A 0~125°C	-	-	0.5	
Output Noise Voltage	$V_N$	10Hz ≤ $f$ ≤ 100kHz 25°C	-	90	-	μV
Output Voltage Drift	$\Delta V_o/\Delta T$	$I_o=5mA$ 0~125°C	-	-1	-	mV/°C
Ripple Rejection	RR	18.5V ≤ $V_I$ ≤ 28.5V, $f=120Hz$ 0~125°C	54	70	-	dB
Dropout Voltage	$V_d$	$I_o=1A$ 25°C	-	2	-	V
Output Resistance	$R_o$	$f=1kHz$ 25°C	-	19	-	mΩ
Short Circuit Current	$I_{SC}$	25°C	-	230	-	mA
Peak Current	$I_{PK}$	25°C	-	2.1	-	A



## TYPICAL PERFORMANCE CHARACTERISTICS

### 1. Output Characteristics

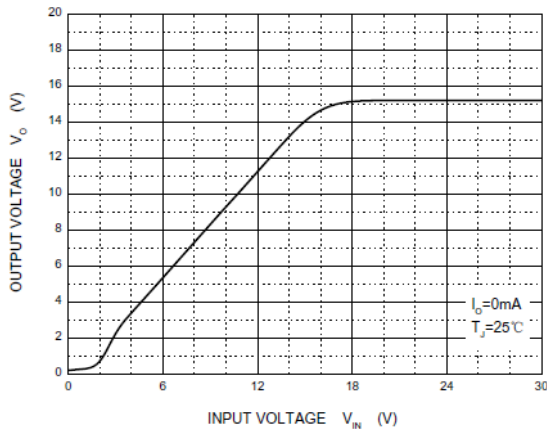

### 2. Dropout Characteristics

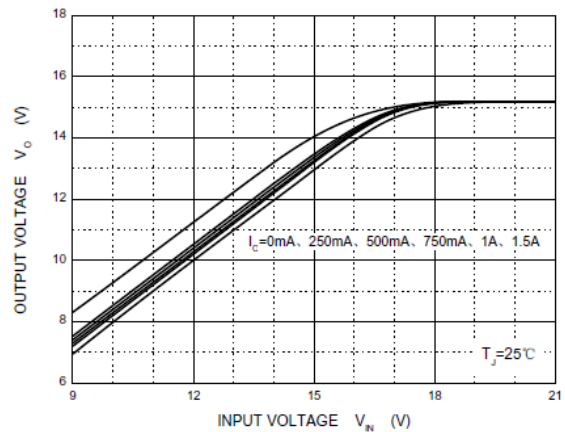

### 3. Quiescent Current vs. Input Voltage

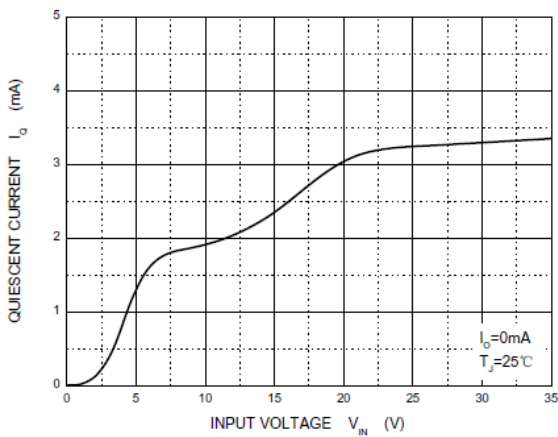

### 4. Quiescent Current vs. Output Current

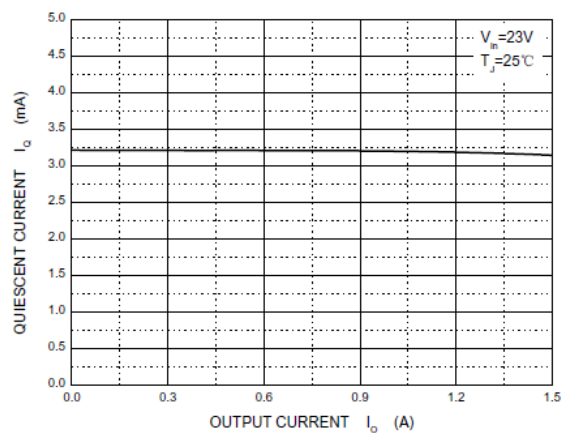

### 5. Output Voltage vs. Ambient Temperature

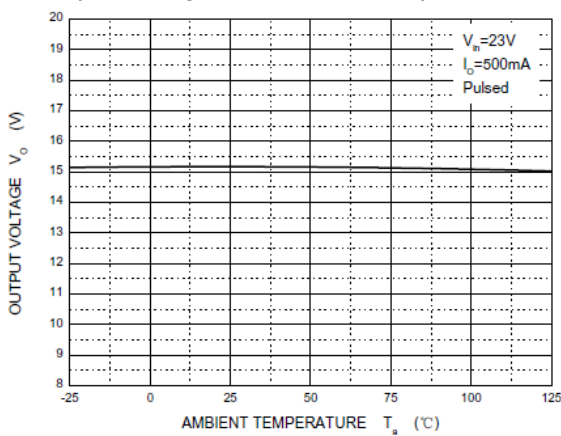

### 6. Current Cut-off Grid Voltage

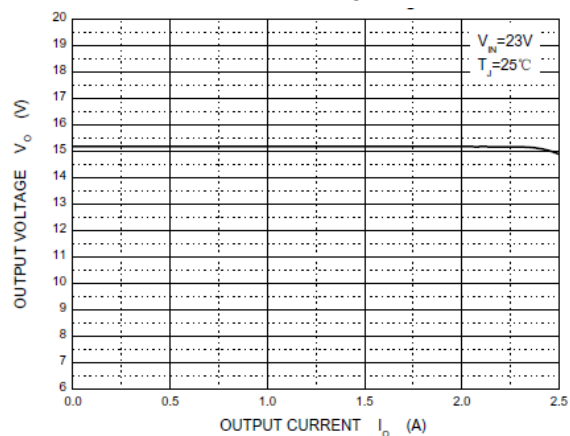



7. Power Derating Curve

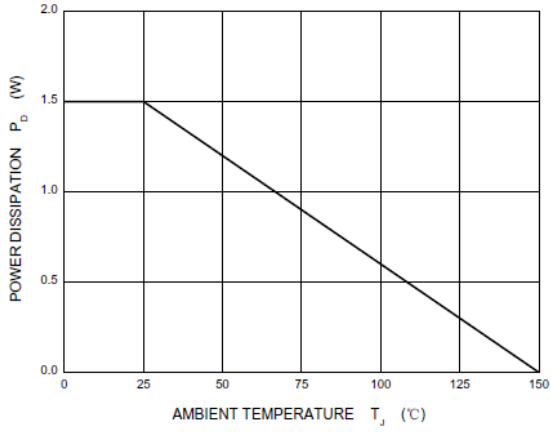



**PACKAGE INFORMATION**

Dimension in TO220-3 (Unit: mm)

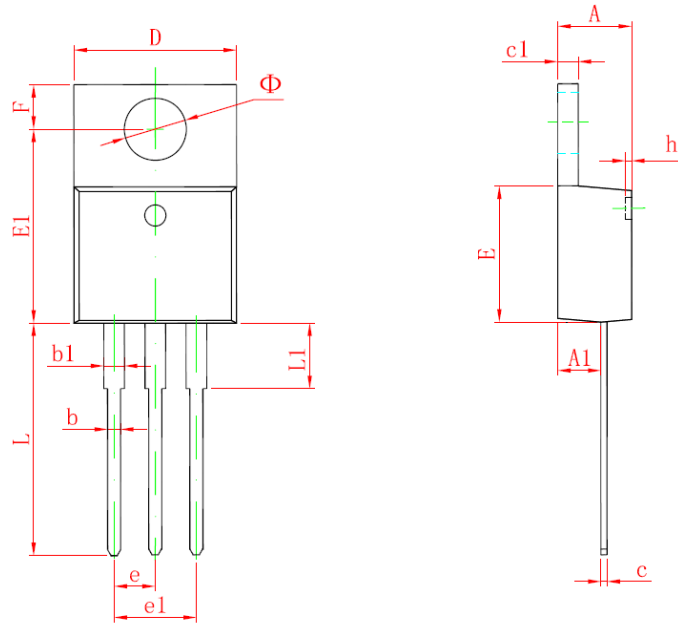

Symbol	Millimeters		Inches	
	Min	Max	Min	Max
A	4.470	4.670	0.176	0.184
A1	2.520	2.820	0.099	0.111
b	0.710	0.910	0.028	0.036
b1	1.170	1.370	0.046	0.054
c	0.310	0.530	0.012	0.021
c1	1.170	1.370	0.046	0.054
D	10.010	10.310	0.394	0.406
E	8.500	8.900	0.335	0.350
E1	12.060	12.460	0.475	0.491
e	2.540 TYP.		0.100 TYP.	
e1	4.980	5.180	0.196	0.204
F	2.590	2.890	0.102	0.114
h	0.000	0.300	0.000	0.012
L	13.400	13.800	0.528	0.543
L1	3.560	3.960	0.140	0.156
Φ	3.735	3.935	0.147	0.155



## IMPORTANT NOTICE

AiT Semiconductor Inc. (AiT) reserves the right to make changes to any its product, specifications, to discontinue any integrated circuit product or service without notice, and advises its customers to obtain the latest version of relevant information to verify, before placing orders, that the information being relied on is current.

AiT Semiconductor Inc.'s integrated circuit products are not designed, intended, authorized, or warranted to be suitable for use in life support applications, devices or systems or other critical applications. Use of AiT products in such applications is understood to be fully at the risk of the customer. As used herein may involve potential risks of death, personal injury, or server property, or environmental damage. In order to minimize risks associated with the customer's applications, the customer should provide adequate design and operating safeguards.

AiT Semiconductor Inc. assumes to no liability to customer product design or application support. AiT warrants the performance of its products of the specifications applicable at the time of sale.