



## DESCRIPTION

Three-terminal negative voltage regulator.

The A79LXX is available in SOT-23, SOT-89-3 and TO-92 Packages.

## FEATURES

- Maximum Output current  $I_{OM}$ : 100mA
- Output voltage  $V_O$ : -5V/-6/-8/-9/-12
- Continuous total dissipation  
SOT-23  $P_D$ : 0.35W  
SOT-89-3  $P_D$ : 0.5W  
TO-92  $P_D$ : 0.625W
- Available in SOT-23, SOT-89-3 and TO-92 Packages

## ORDERING INFORMATION

Package Type	Part Number	
SOT-23	E3	A79LXXE3R
		A79LXXE3VR
SOT-89-3	K3	A79LXXK3R
		A79LXXK3VR
TO-92	Z	A79LXXZA
		A79LXXZVA
		A79LXXZB
		A79LXXZVB
Note	XX: Output Voltage 05=5.0V, 12=12V A: Ammo Pack B: Bulk R: Tape & Reel V: Halogen free Package	
AiT provides all RoHS products Suffix "V" means Halogen free Package		

## TYPICAL APPLICATION

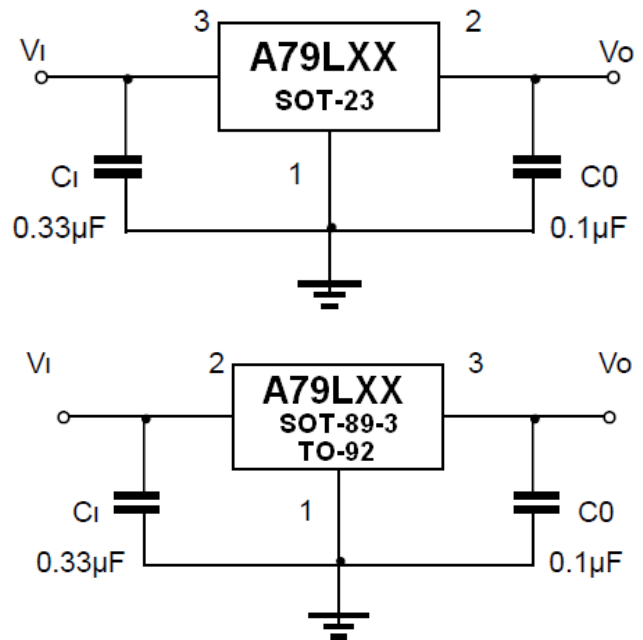

NOTE: Bypass capacitors are recommended for optimum stability and transient response and should be located as close as Possible to the regulators.



**PIN DESCRIPTION**

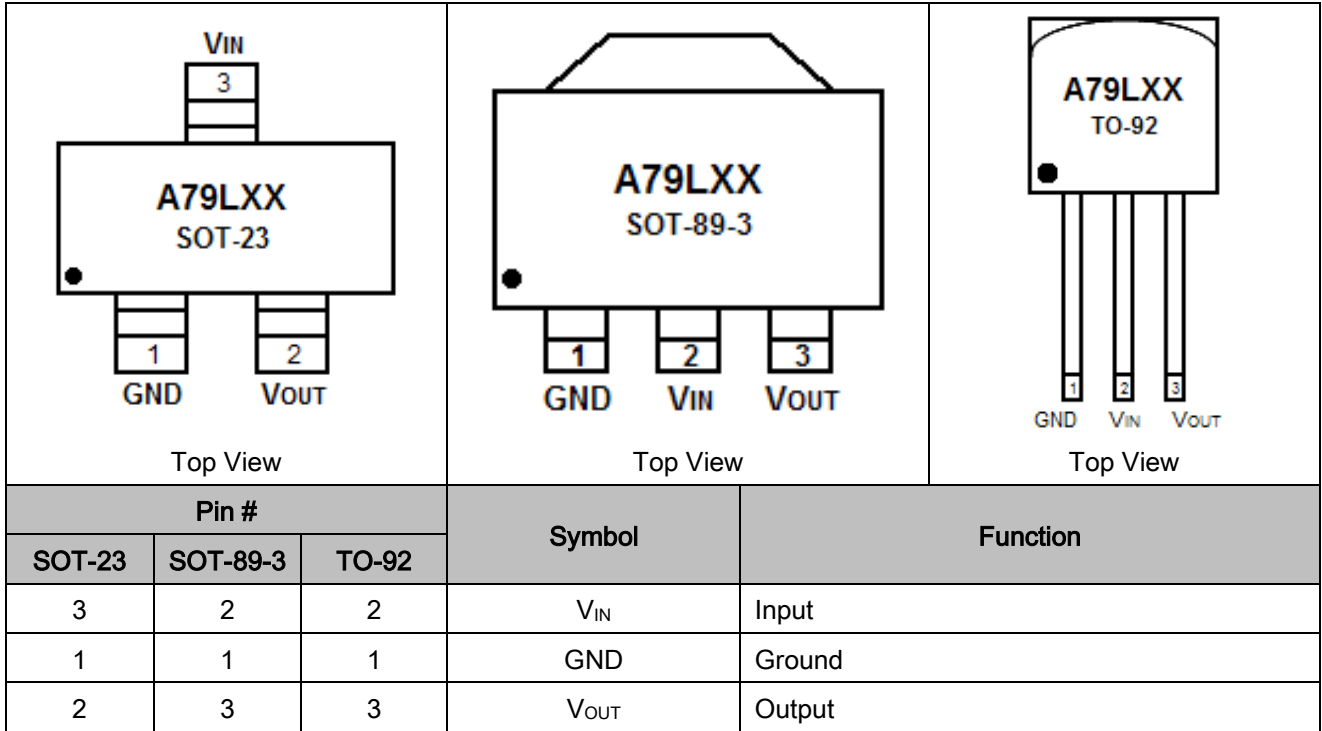



## ABSOLUTE MAXIMUM RATINGS

Operating temperature range applies unless otherwise specified

V <sub>I</sub> , Input Voltage	79L05~79L09	-30V
	79L12	-35V
T <sub>OPR</sub> , Operating Junction Temperature Range		0°C ~+125°C
T <sub>STG</sub> , Storage Temperature Range		-55°C ~ +150°C

Stresses above may cause permanent damage to the device. These are stress ratings only, and functional operation of the device at these or any other conditions beyond those indicated in the Electrical Characteristics is not implied. Exposure to absolute maximum rating conditions for extended periods may affect device reliability.



## ELECTRICAL CHARACTERISTICS

$V_I = -10V(A79L05)$ ,  $V_I = -11V(A79L06)$ ,  $V_I = -14V(A79L08)$ ,  $V_I = -16V(A79L09)$ ,  $V_I = -19V(A79L12)$ ,  
 $I_O = 40mA$ ,  $C_I = 0.33\mu F$ ,  $C_O = 0.1\mu F$ , unless otherwise specified

Parameter	Symbol	Conditions		Min.	Typ.	Max.	Unit			
Output Voltage	$V_O$		5V	25°C	-4.8	-5.0	-5.2	V		
			6V		-5.75	-6.0	-6.3			
			8V		-7.7	-8.0	-8.3			
			9V		-8.64	-9.0	-9.36			
			12V		-11.5	-12	-12.5			
				-7V ≤ $V_I$ ≤ -20V, $I_O = 1mA \sim 40mA$	5V	0~ 125°C	-4.75		-5.0	-5.25
				$I_O = 1mA \sim 70mA$						
				-8V ≤ $V_I$ ≤ -20V, $I_O = 1mA \sim 40mA$	6V		-5.7		-6.0	-6.3
				$I_O = 1mA \sim 70mA$						
				-10.5V ≤ $V_I$ ≤ -23V, $I_O = 1mA \sim 40mA$	8V		-7.6		-8.0	-8.4
				$I_O = 1mA \sim 70mA$						
				-12V ≤ $V_I$ ≤ -24V, $I_O = 1mA \sim 40mA$	9V		-8.55		-9.0	-9.45
				$I_O = 1mA \sim 70mA$						
				-14.5V ≤ $V_I$ ≤ -27V, $I_O = 1mA \sim 40mA$	12V		-11.4		-12	-12.6
		$I_O = 1mA \sim 70mA$								
Load Regulation	$\Delta V_O$	$I_O = 1mA \sim 100mA$	5V	25°C	-		20	60	mV	
			6V				21	80		
			8V				30	100		
			9V				19	90		
			12V			24	100			
		$I_O = 1mA \sim 40mA$	5V			10	30			
			6V			11	40			
			8V			15	50			
			9V			11	40			
			12V			15	50			



Parameter	Symbol	Conditions		Min.	Typ.	Max.	Unit		
Line Regulation	$\Delta V_o$	$-7V \leq V_I \leq -20V$	5V	25°C	-	15	150	mV	
		$-8V \leq V_I \leq -20V$				12	100		
		$-8V \leq V_I \leq -20V$	6V			20	175		
		$-9V \leq V_I \leq -20V$				15	125		
		$-10.5V \leq V_I \leq -23V$	8V			42	200		
		$-11V \leq V_I \leq -23V$				36	150		
		$-12V \leq V_I \leq -24V$	9V			45	175		
		$-13V \leq V_I \leq -24V$				40	125		
		$-14.5V \leq V_I \leq -27V$	12V			50	250		
		$-16V \leq V_I \leq -27V$				40	200		
Quiescent Current	$I_q$		5V	25°C	-	-	6.0	mA	
			6V			3.9			
			8V			4.0			
			9V			4.1			
			12V			-			6.5
Quiescent Current Change	$\Delta I_q$	$-8V \leq V_I \leq -20V$	5V	0~125°C	-	-	1.5	mA	
		$-9V \leq V_I \leq -20V$	6V						
		$-11V \leq V_I \leq -23V$	8V						
		$-16V \leq V_I \leq -27V$	12V						
		$1mA \leq I_o \leq 40mA$	5V						0.1
			6V						
			8V						
			9V						
	12V								
Output Noise Voltage	$V_N$	$10Hz \leq f \leq 100KHz$	5V	25°C	-	40	-	uV	
			6V			44			
			8V			54			
			9V			58			
			12V			80			
Ripple Rejection	RR	$-8V \leq V_I \leq -18V, f = 120Hz$	5V	0~125°C	-	41	49	dB	
		$-9V \leq V_I \leq -19V, f = 120Hz$	6V			40	48		
		$-11V \leq V_I \leq -21V, f = 120Hz$	8V			37	46		
		$-15V \leq V_I \leq -24V, f = 120Hz$	9V			-	45		
		$-15V \leq V_I \leq -25V, f = 120Hz$	12V			37	42		
Dropout Voltage	$V_d$			25°C	-	1.7	-	V	



### TYPICAL CHARACTERISTICS

1.

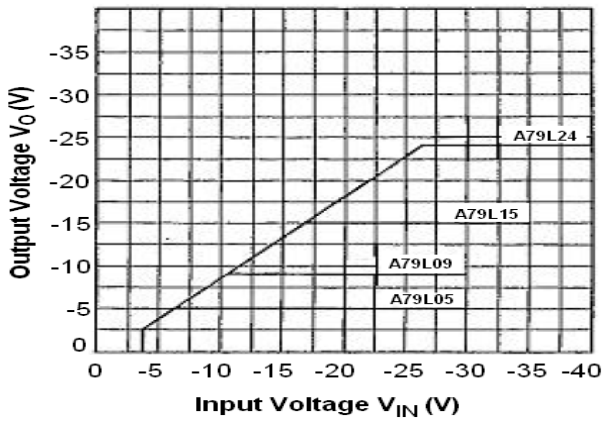

2.

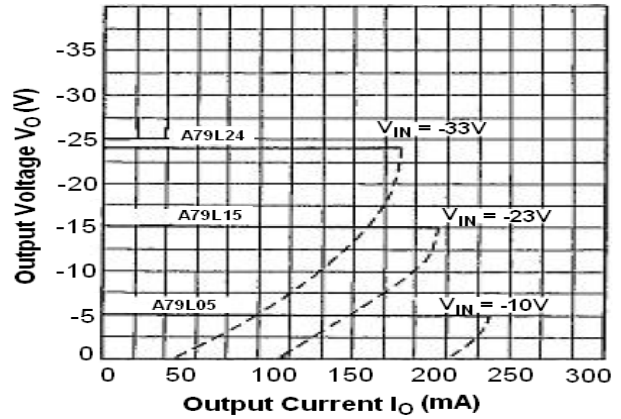

3.

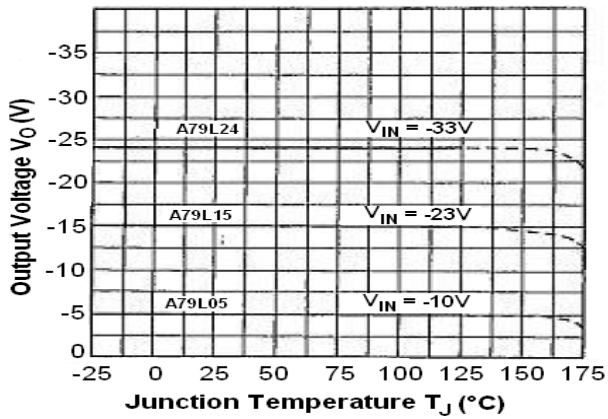

4.

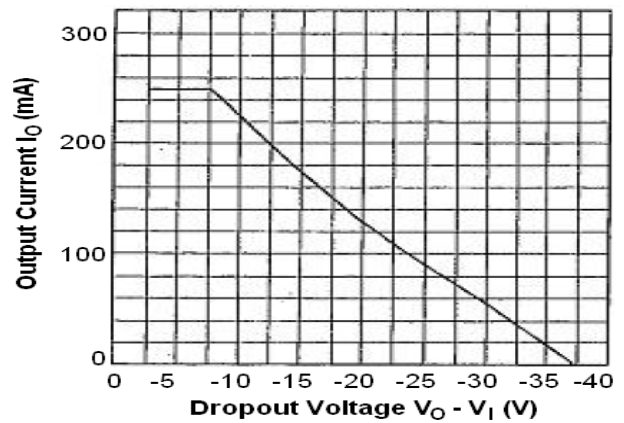

5.

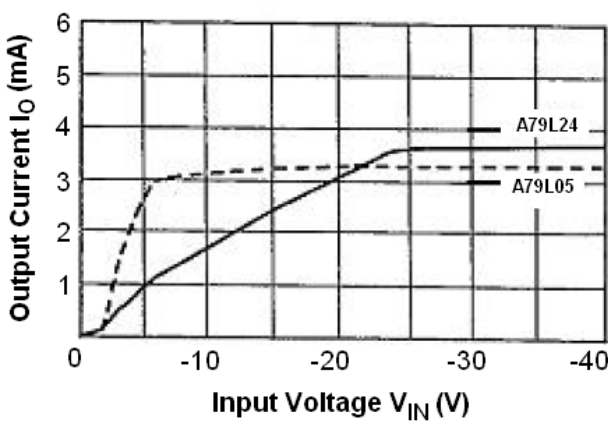

6. PD -  $T_A$  (SOT-23)

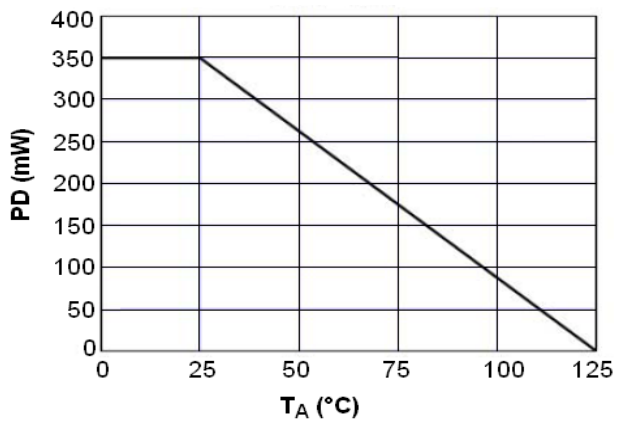



7. PD - T<sub>A</sub> (SOT-89-3)

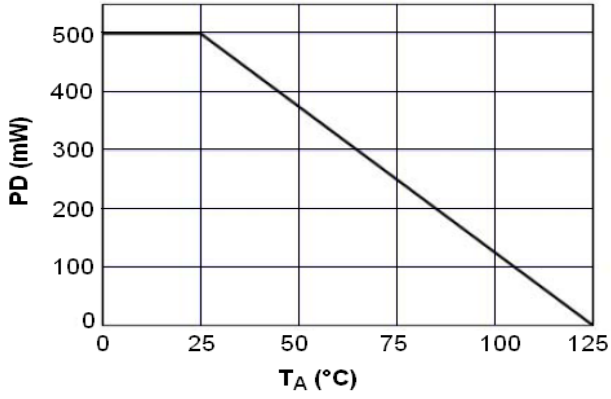

8. PD - T<sub>A</sub> (TO-92)

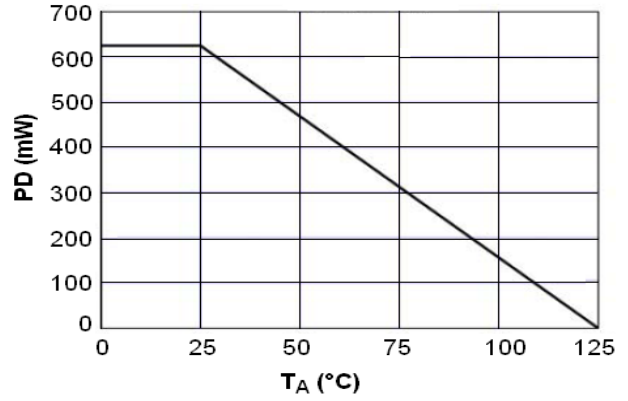



**PACKAGE INFORMATION**

Dimension in SOT-23 Package (Unit: mm)

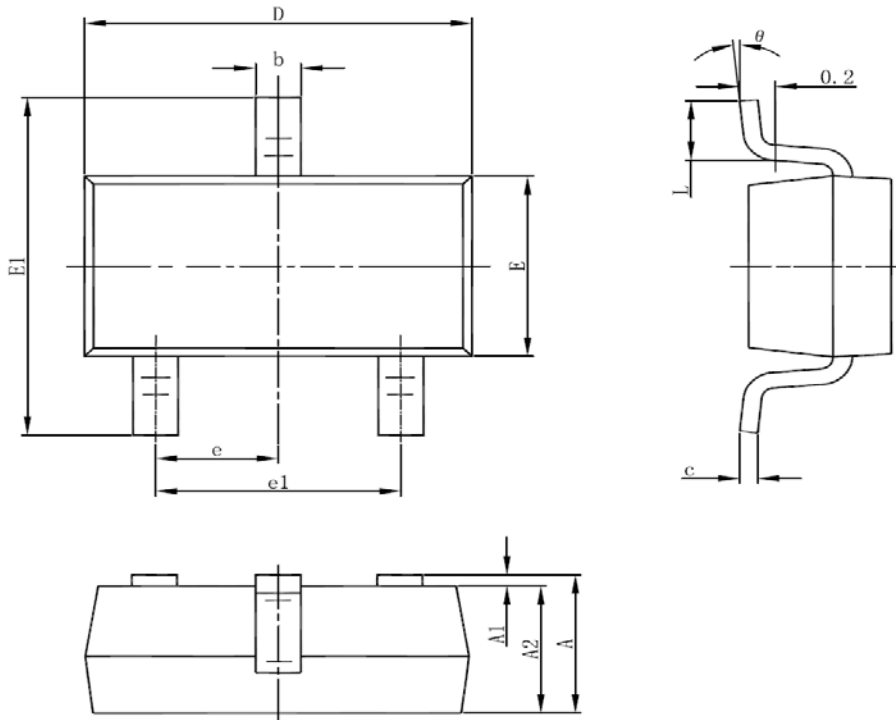

SYMBOL	MIN	MAX
A	1.050	1.250
A1	0.000	0.100
A2	1.050	1.150
b	0.300	0.500
c	0.100	0.200
D	2.820	3.020
E	1.500	1.700
E1	2.650	2.950
e	0.950(BSC)	
e1	1.800	2.000
L	0.300	0.600
θ	0°	8°





Dimension in SOT-89-3 (Unit: mm)

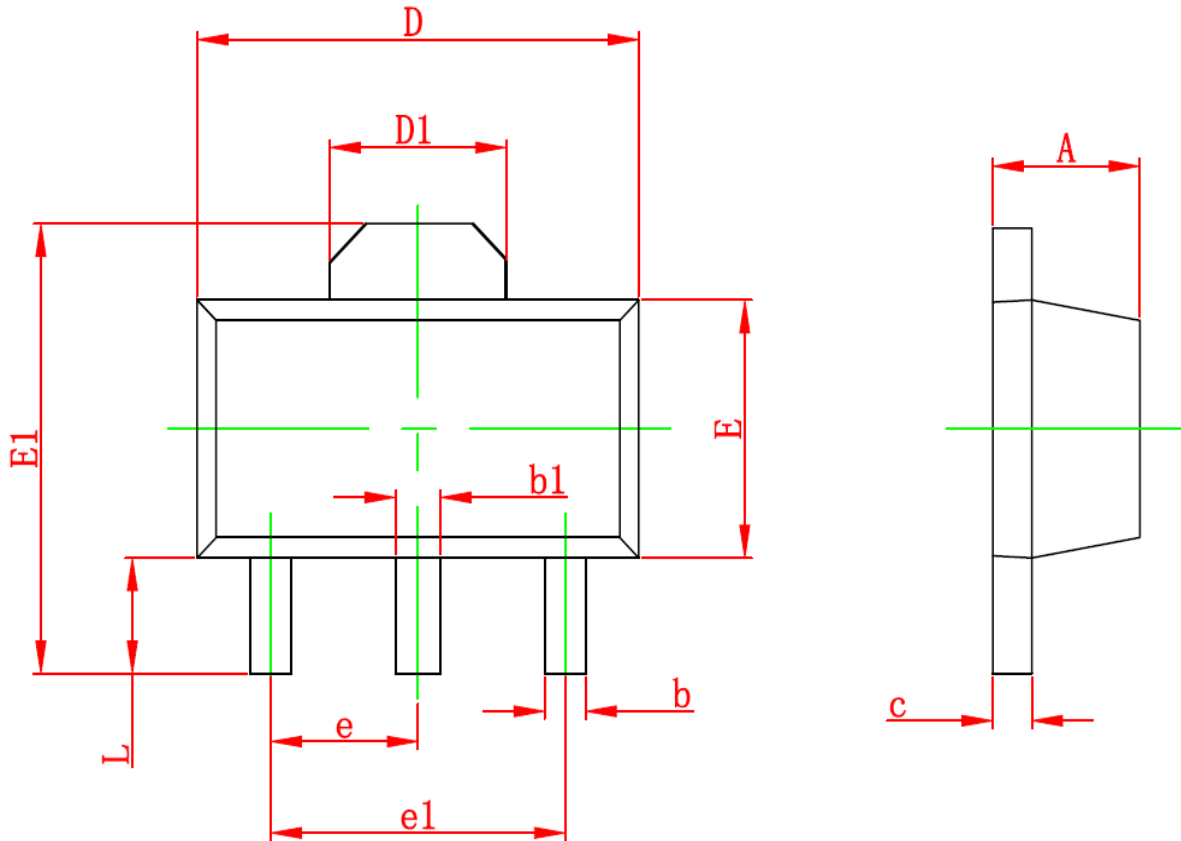

Symbol	Min	Max
A	1.400	1.600
b	0.320	0.520
b1	0.400	0.580
c	0.350	0.440
D	4.400	4.600
D1	1.550 REF	
E	2.300	2.600
E1	3.940	4.250
e	1.500 TYP	
e1	3.000 TYP	
L	0.900	1.200



Dimension in TO-92 (Unit: mm)

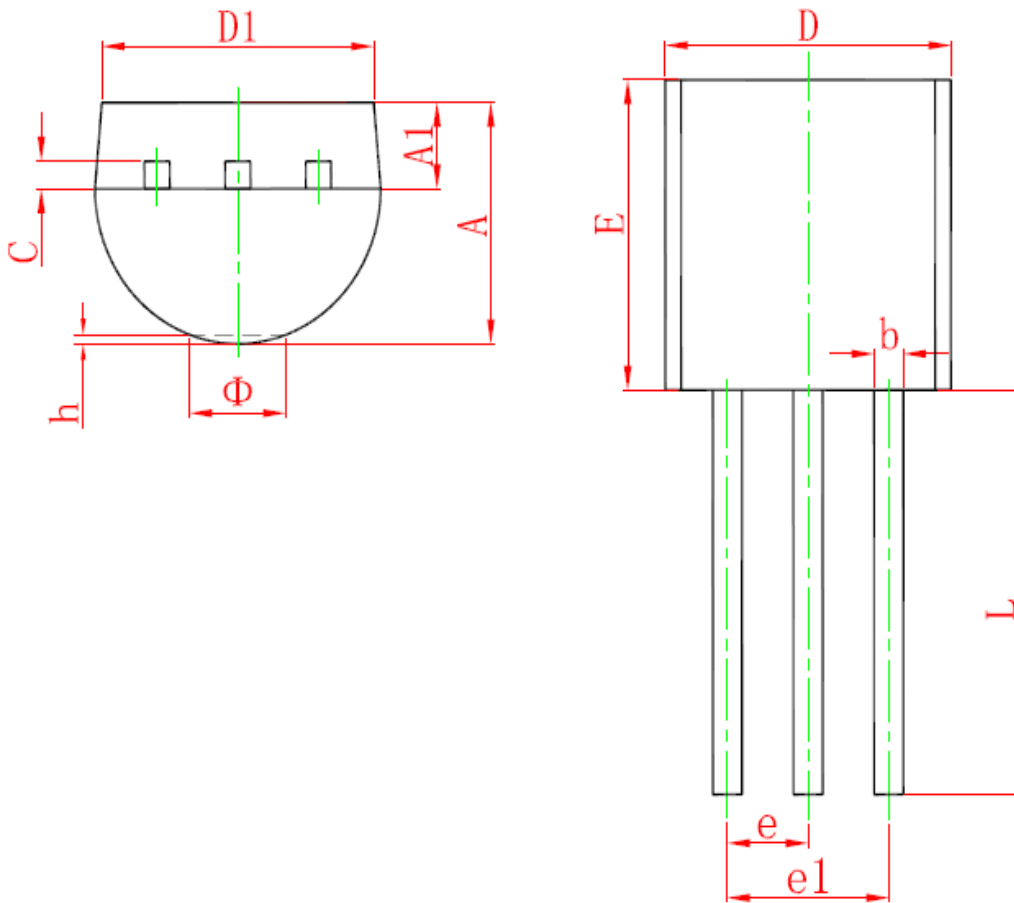

Symbol	Min	Max
A	3.300	3.700
A1	1.100	1.400
b	0.380	0.550
c	0.360	0.510
D	4.400	4.700
D1	3.430	-
E	4.300	4.700
e	1.270 TYP	
e1	2.440	2.640
L	14.100	14.500
Φ	-	1.600
h	0.000	0.380



## IMPORTANT NOTICE

AiT Semiconductor Inc. (AiT) reserves the right to make changes to any its product, specifications, to discontinue any integrated circuit product or service without notice, and advises its customers to obtain the latest version of relevant information to verify, before placing orders, that the information being relied on is current.

AiT Semiconductor Inc.'s integrated circuit products are not designed, intended, authorized, or warranted to be suitable for use in life support applications, devices or systems or other critical applications. Use of AiT products in such applications is understood to be fully at the risk of the customer. As used herein may involve potential risks of death, personal injury, or severe property, or environmental damage. In order to minimize risks associated with the customer's applications, the customer should provide adequate design and operating safeguards.

AiT Semiconductor Inc. assumes to no liability to customer product design or application support. AiT warrants the performance of its products of the specifications applicable at the time of sale.