



DESCRIPTION

The A8176 is a constant frequency, SOT-25 current mode step-up converter intended for small, low power applications. The A8176 switches at 1.0MHz and allows the use of tiny, low cost capacitors and inductors 2mm or less in height. Internal soft-start results in small inrush current and extends battery life. The A8176 operates from an input voltage as low as 3.0V and can generate 24V at up to 80mA from a 5V supply.

The A8176 includes current limiting, and thermal overload protection to prevent damage in the event of an output overload.

The A8176 is available in SOT-25 package.

ORDERING INFORMATION

Package Type	Part Number	
SOT-25 SPQ: 3,000pcs/Reel	E5	A8176E5R
		A8176E5VR
Note	V: Halogen free Package R: Tape & Reel	
AiT provides all RoHS products		

FEATURES

- Integrated 0.7Ω Power MOSFET
- 400μA Quiescent Current
- 3.0V to 5.5V Input Voltage
- 1.0MHz Fixed Switching Frequency
- Internal 1.2A Switch Current Limit
- Adjustable Output Voltage
- Internal Compensation
- Up to 24V Output Voltage
- Over 85% Efficiency
- Available in SOT-25 Package

APPLICATION

- OLED Biasing
- LCD Bias Supply
- White LED Driver
- PDAs
- Digital Still Cameras

TYPICAL APPLICATION

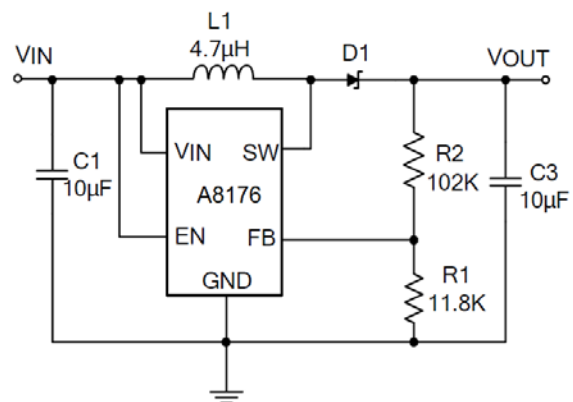
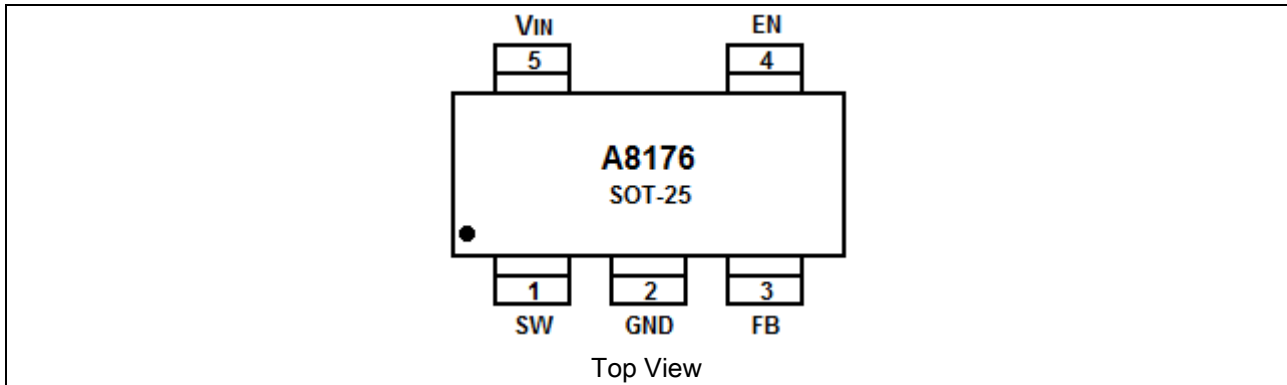

Figure 1. Basic Application Circuit with A8176



PIN DESCRIPTION



Pin #	Symbol	Function
1	SW	Switching Pin
2	GND	Ground Pin
3	FB	Feedback Pin. Feedback voltage is 1.23V
4	EN	Chip Enable (Active High)
5	V _{IN}	Input Supply

ABSOLUTE MAXIMUM RATINGS

V _{IN} , Supply Input Voltage	-0.3V~ 6V
SW, Switching Pin	-0.3V~ 30V
Other Pins	-0.3V~ 6V
P _D , Power Dissipation @ T _A =25°C	SOT-25 0.392W
Package Thermal Resistance ^{NOTE 1}	
SOT-25, θ _{JA}	255°C/W
Lead Temperature (Soldering, 10 sec.)	260°C
Junction Temperature	150°C
Storage Temperature Range	-65°C ~150°C

Stress beyond above listed "Absolute Maximum Ratings" may lead permanent damage to the device. These are stress ratings only and operations of the device at these or any other conditions beyond those indicated in the operational sections of the specifications are not implied. Exposure to absolute maximum rating conditions for extended periods may affect device reliability.

NOTE1: θ_{JA} is measured in the natural convection at T_A = 25°C on a low effective single layer thermal conductivity test board of JEDEC 51-3 thermal measurement standard.



RECOMMENDED OPERATING CONDITIONS^{NOTE2}

Parameter	Min.	Max.	Units
Junction Temperature Range	-40	125	°C
Ambient Temperature Range	-40	85	°C

NOTE2: The device is not guaranteed to function outside its operating conditions.

ELECTRICAL CHARACTERISTICS

$V_{IN}=3.7V$, $T_A = 25^{\circ}C$, unless otherwise specified

Parameter	Conditions	Min.	Typ.	Max.	Unit
Operating Input Voltage		3	-	5.5	V
Under Voltage Lockout		2	2.2	2.45	V
Under Voltage Lockout Hysteresis		-	100	-	mV
Current (Shutdown)	$V_{EN}=0V$	-	1	5	μA
Quiescent Current	$V_{FB}=1.5V$, NO switch	-	400	600	μA
Supply Current	$V_{FB}=0V$, switch	-	1	2	mA
Switching Frequency		0.75	1	1.25	MHz
Maximum Duty Cycle	$V_{FB}=0V$	90	92	-	%
EN Input High Voltage		1.4	-	-	V
EN Input Low Voltage		-	-	0.5	V
FB Voltage		1.193	1.23	1.267	V
FB Input Bias Current	$V_{FB}=1.23V$	-	-10	-	nA
SW ON Resistance		-	0.7	-	Ω
SW Current Limit	$V_{IN}=3.7V$, Duty Cycle=50%	-	1.2	-	A
SW Leakage	$V_{SW}=24V$	-	-	1	μA
Soft Start		-	200	-	μs
Over Temperature Shutdown		-	160	-	°C
Over Temperature Hysteresis		-	40	-	°C



TYPICAL PERFORMANCE CHARACTERISTICS

1. I_q vs. V_{IN}

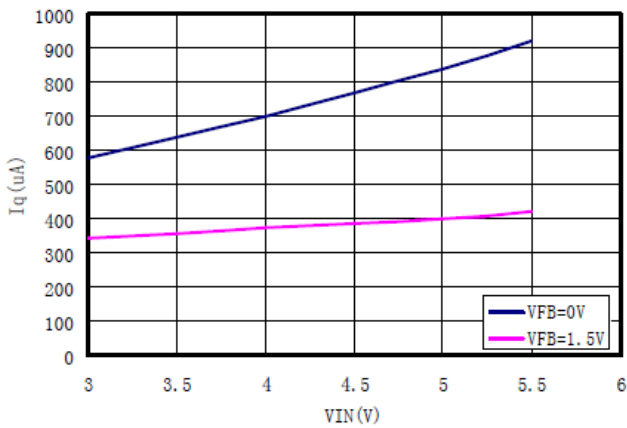

2. f vs. V_{IN}

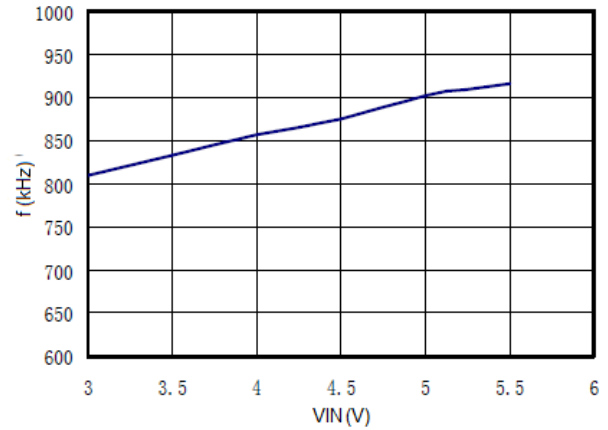

3. V_{FB} vs. V_{IN}

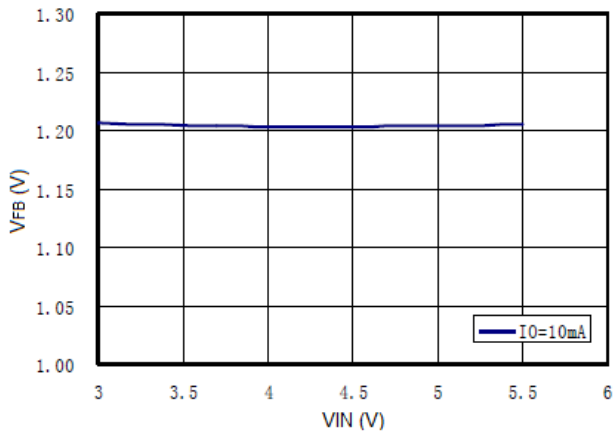

4. V_{EN} vs. V_{IN}

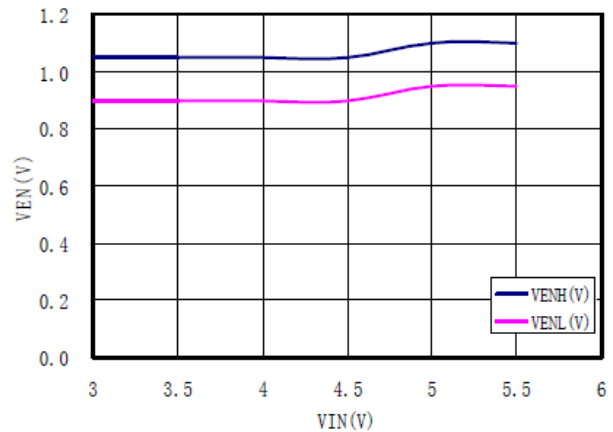

5. Power On/Off from EN (CH1:EN,CH2:Vo)

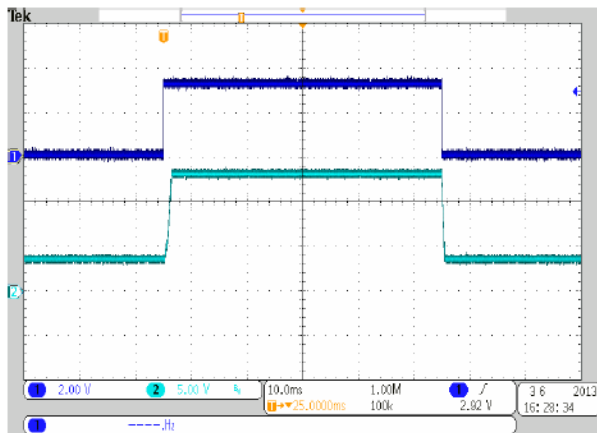

6. Normal Operation (CH1:SW,CH2:Vo,CH4:Isw)

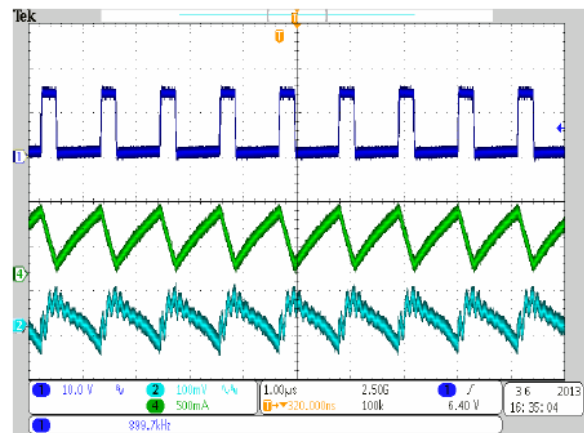



7. η vs. I_O

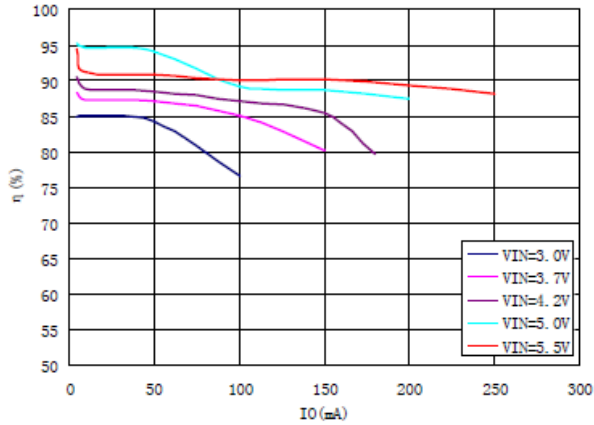

BLOCK DIAGRAM

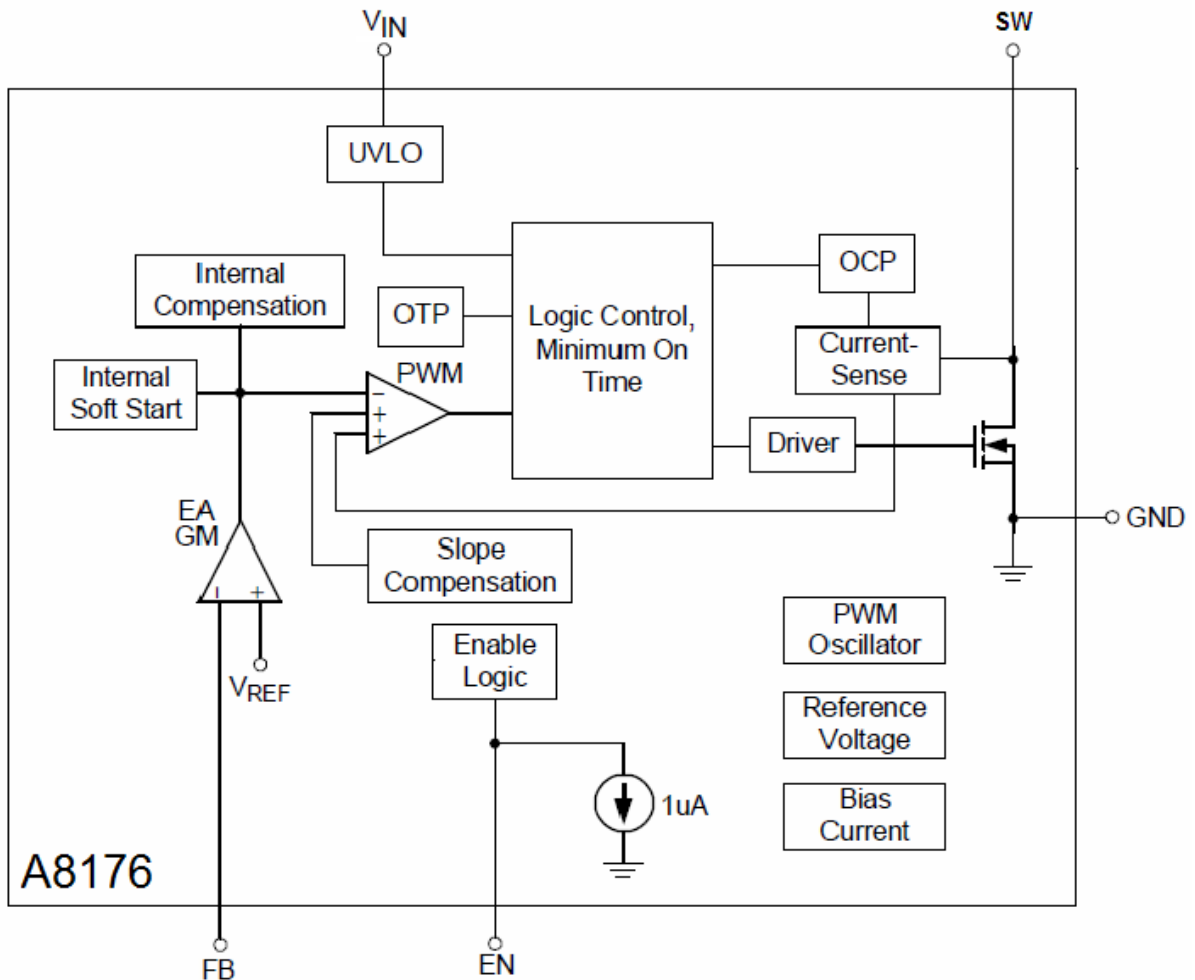



DETAILED INFORMATION

Setting the Output Voltage

The internal reference V_{REF} is 1.23V (Typical). The output voltage is divided by a resistor divider, R2 and R1 to the FB pin. The output voltage is given by

$$V_{OUT} = 1.23V \times \left(1 + \frac{R2}{R1}\right)$$

Power Sequence

In order to assure the normal soft start function for suppressing the inrush current the input voltage should be ready before EN pulls high.

Soft-Start

The function of soft-start is made for suppressing the inrush current to an acceptable value at the beginning of power-on. The A8176 provides a built-in soft-start function by clamping the output voltage of error amplifier so that the duty cycle of the PWM will be increased gradually in the soft-start period.

Current Limiting

The current flow through inductor as charging period is detected by a current sensing circuit. As the value comes across the current limiting threshold, the N-MOSFET will be turned off so that the inductor will be forced to leave charging stage and enter discharging stage. Therefore, the inductor current will not increase over the current limiting threshold.

Capacitor Selection

Input ceramic capacitor of 10uF and output ceramic capacitor of 10uF are recommended for the A8176 applications. For better voltage filtering, ceramic capacitors with low ESR are recommended. X5R and X7R types are suitable because of their wider voltage and temperature ranges.

Inductor Selection

The recommended value of inductor are 4.7 to 22μH. Small size and better efficiency are the major concerns for portable device. Small size and better efficiency are the major concerns for portable devices, such as the A8176 used for mobile phone. The inductor should have low core loss at 1.0MHz and low DCR for better efficiency. The inductor saturation current rating should be considered to cover the inductor peak current.



Diode Selection

Schottky diode is a good choice for A8176 because of its low forward voltage drop and fast reverse recovery. Using Schottky diode can get better efficiency. The high speed rectification is also a good characteristic of Schottky diode for high switching frequency. Current rating of the diode must meet the root mean square of the peak current and output average current multiplication as following:

$$I_D(\text{RMS}) \approx \sqrt{I_{\text{OUT}} \times I_{\text{PEAK}}}$$

The diode's reverse breakdown voltage should be larger than the output voltage.

Layout Consideration

For best performance of the A8176, the following guidelines must be strictly followed.

- Input and Output capacitors should be placed close to the IC and connected to ground plane to reduce noise coupling.
- The GND and Exposed Pad should be connected to a strong ground plane for heat sinking and noise protection.
- Keep the main current traces as possible as short and wide.
- SW node of DC-DC converter is with high frequency voltage swing. It should be kept at a small area.
- Place the feedback components as close as possible to the IC and keep away from the noisy devices.

TYPICAL APPLICATION CIRCUITS

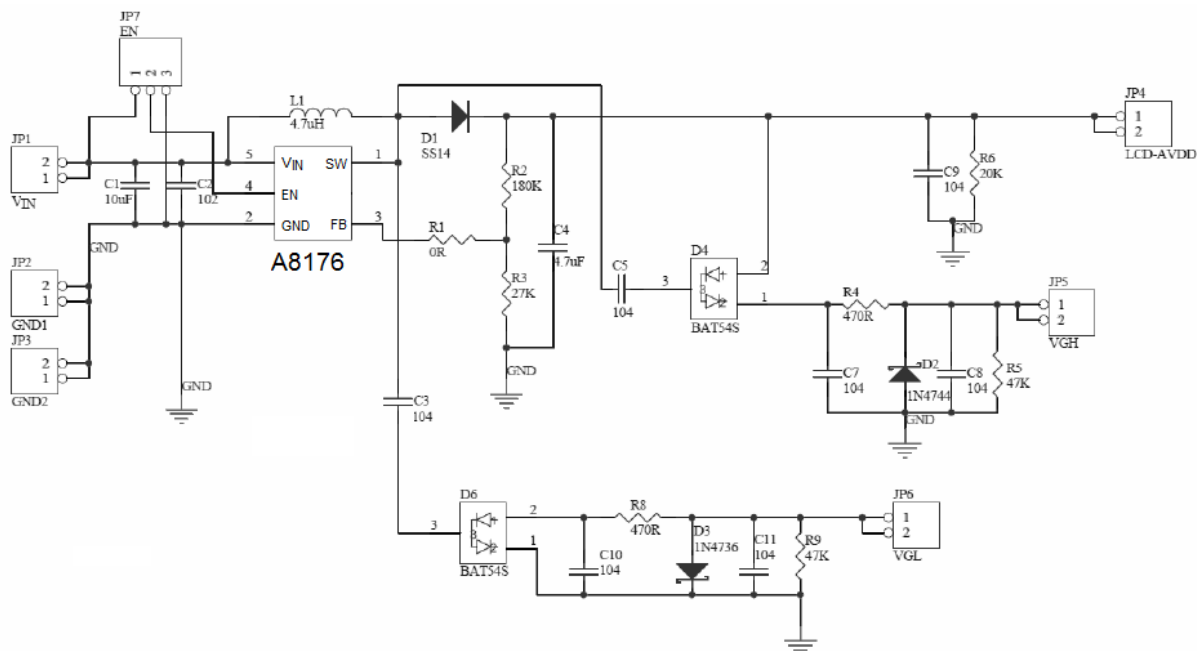
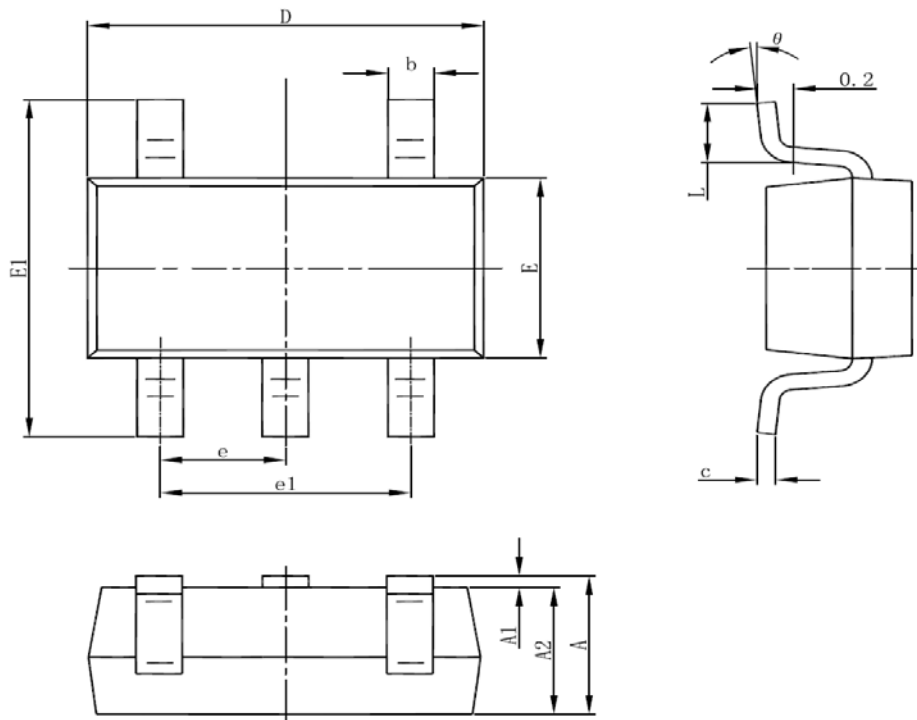

Figure 2 LCD Display Power



PACKAGE INFORMATION

Dimension in SOT-25 (Unit: mm)



Symbol	Millimeters		Inches	
	Min	Max	Min	Max
A	1.050	1.250	0.041	0.049
A1	0.000	0.100	0.000	0.004
A2	1.050	1.150	0.041	0.045
b	0.300	0.500	0.012	0.020
c	0.100	0.200	0.004	0.008
D	2.820	3.020	0.111	0.119
E	1.500	1.700	0.059	0.067
E1	2.650	2.950	0.104	0.116
e	0.950(BSC)		0.037(BSC)	
e1	1.800	2.000	0.071	0.079
L	0.300	0.600	0.012	0.024
θ	0°	8°	0°	8°



IMPORTANT NOTICE

AiT Semiconductor Inc. (AiT) reserves the right to make changes to any its product, specifications, to discontinue any integrated circuit product or service without notice, and advises its customers to obtain the latest version of relevant information to verify, before placing orders, that the information being relied on is current.

AiT Semiconductor Inc.'s integrated circuit products are not designed, intended, authorized, or warranted to be suitable for use in life support applications, devices or systems or other critical applications. Use of AiT products in such applications is understood to be fully at the risk of the customer. As used herein may involve potential risks of death, personal injury, or server property, or environmental damage. In order to minimize risks associated with the customer's applications, the customer should provide adequate design and operating safeguards.

AiT Semiconductor Inc. assumes to no liability to customer product design or application support. AiT warrants the performance of its products of the specifications applicable at the time of sale.