

High Voltage Transistor

A94

FEATURES

- Collector-Emitter voltage: $V_{CEO} = -400V$.
- Collector Dissipation: $P_{C(MAX)} = 350mW$.
- Low collector-Emitter saturation voltage.

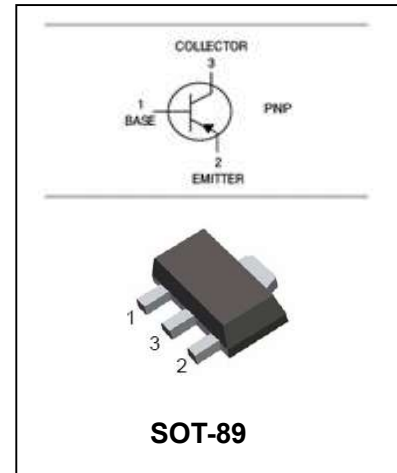

APPLICATIONS

- High voltage switch.
- Telephone switching.

ORDERING INFORMATION

Type No.	Marking	Package Code
A94	A94	SOT-89

MAXIMUM RATING @ $T_a = 25^\circ C$ unless otherwise specified

Symbol	Parameter	Value	UNIT
V_{CBO}	collector-base voltage	-400	V
V_{CEO}	collector-emitter voltage	-400	V
V_{EBO}	emitter-base voltage	-6	V
I_C	collector current (DC)	-0.3	A
P_C	Collector dissipation	0.35	W
T_j, T_{stg}	junction and storage temperature	-40 to +150	$^\circ C$

High Voltage Transistor

A94

ELECTRICAL CHARACTERISTICS @ Ta=25°C unless otherwise specified

Symbol	Parameter	Test conditions	MIN.	MAX.	UNIT
$V_{(BR)CBO}$	Collector-base breakdown voltage	$I_C = -100\mu A, I_E = 0$	-400	-	V
$V_{(BR)CEO}$	Collector-emitter breakdown voltage	$I_C = -1.0mA, I_B = 0$	-400	-	V
$V_{(BR)CES}$	Collector-emitter breakdown voltage	$I_C = -100\mu A, V_{BE} = 0$	-400	-	V
$V_{(BR)EBO}$	Emitter-base breakdown voltage	$I_E = -100\mu A, I_C = 0$	-5	-	V
I_{CBO}	collector cut-off current	$I_E = 0, V_{CB} = -300V$	-	-0.1	μA
I_{CES}	collector cut-off current	$V_{BE} = 0, V_{CE} = -400V$	-	-1	μA
I_{EBO}	emitter cut-off current	$I_C = 0, V_{EB} = -4V$	-	-0.1	μA
h_{FE}	DC current gain	$V_{CE} = -10V; I_C = -1mA$	60	-	
		$V_{CE} = -10V; I_C = -10mA$	70	300	
		$V_{CE} = -10V; I_C = -50mA$	70	-	
		$V_{CE} = -10V; I_C = -100mA$	40	-	
$V_{CE(sat)}$	Collector-emitter saturation voltage	$I_C = -10mA; I_B = -1mA$ $I_C = -50mA; I_B = -5mA$	-	-0.20 -0.5	V
$V_{BE(sat)}$	Base-emitter saturation voltage	$I_C = 10mA; I_B = 1mA$	-	-0.75	V
C_{ob}	Output Capacitance	$V_{CB} = -20V, I_E = 0, f = 1MHz$	-	7	pF

TYPICAL CHARACTERISTICS @ Ta=25°C unless otherwise specified

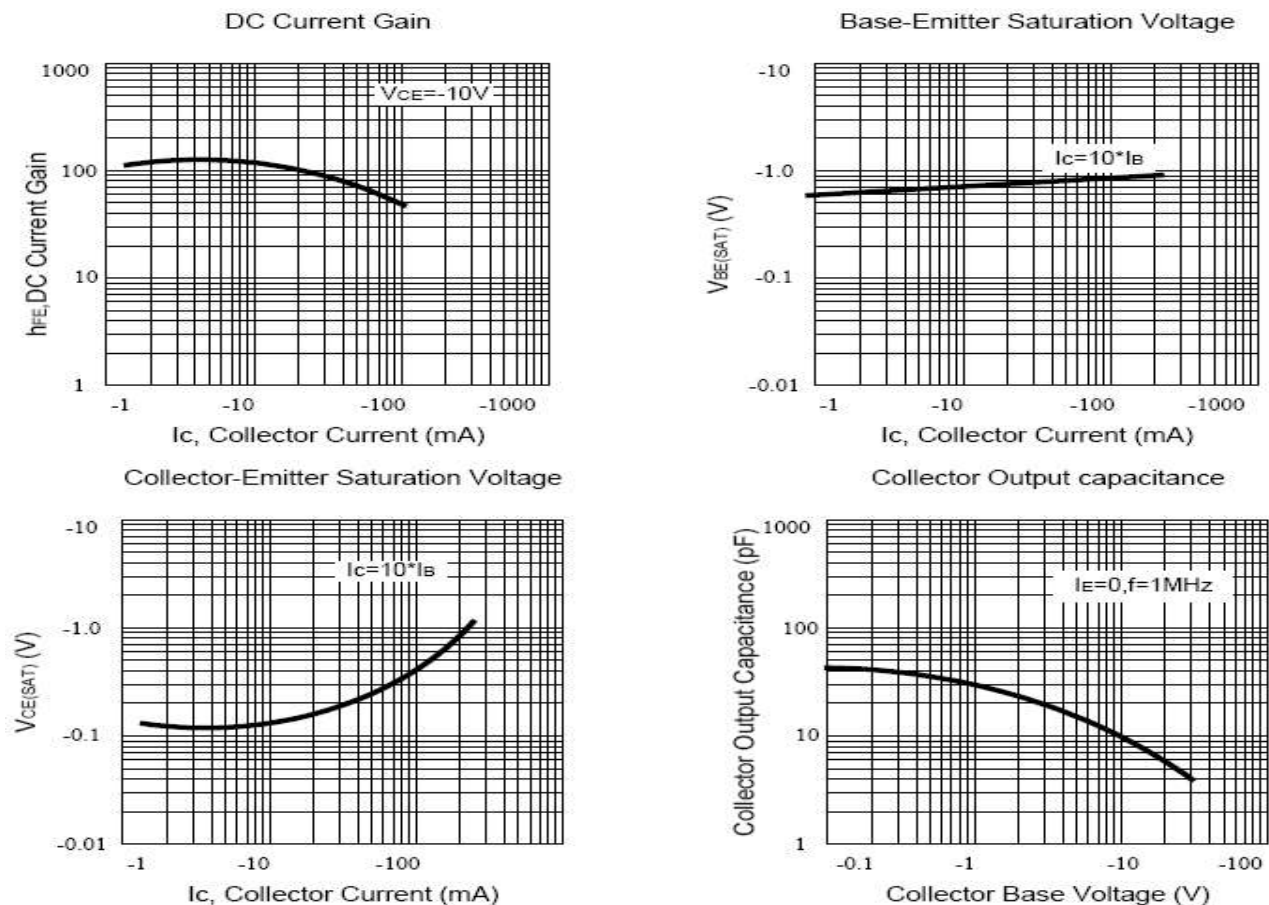

High Voltage Transistor

A94

PACKAGE OUTLINE

Plastic surface mounted package

SOT-89

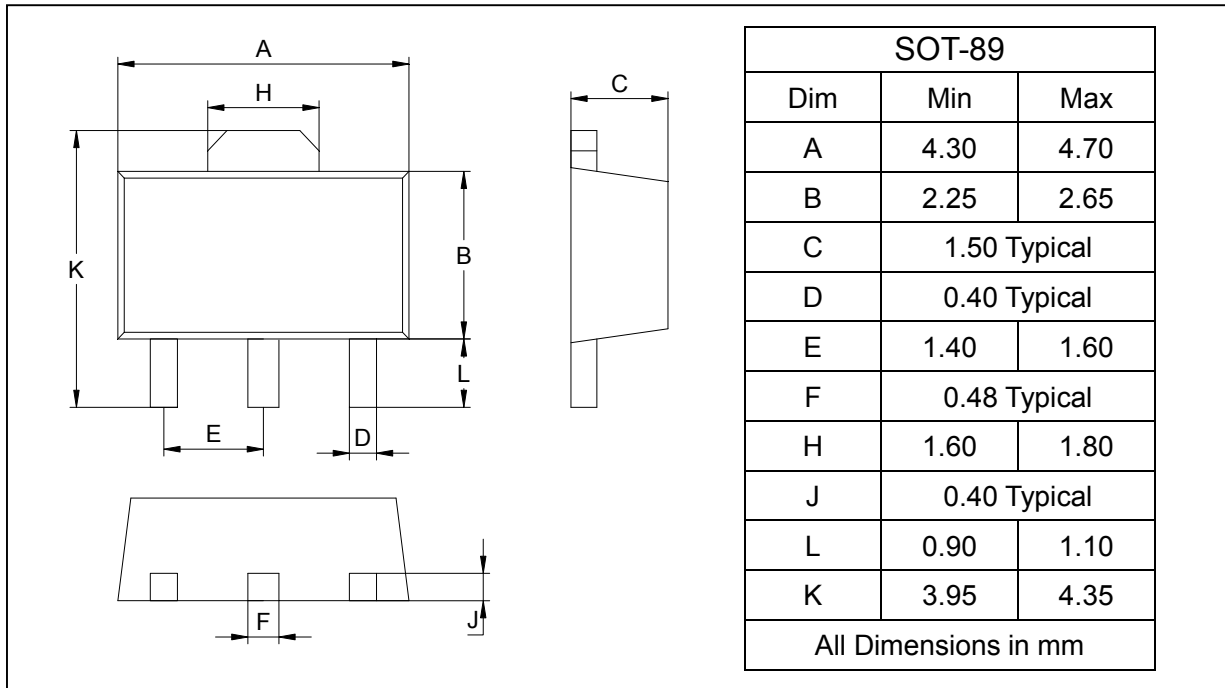

SOLDERING FOOTPRINT

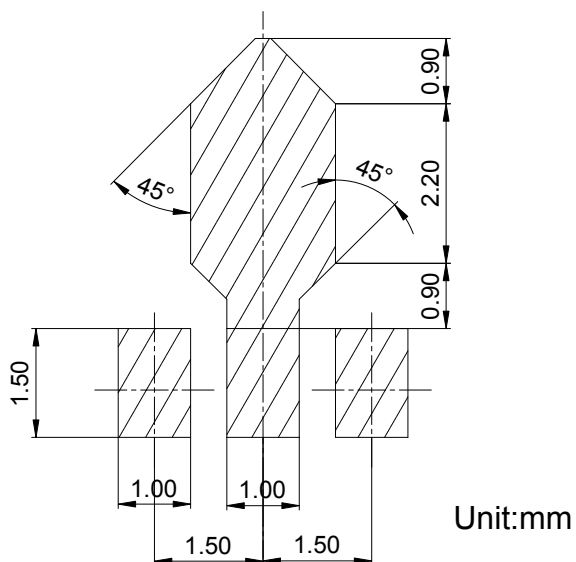

PACKAGE INFORMATION

Device	Package	Shipping
A94	SOT-89	1000/Tape&Reel