

DESCRIPTION

The AA51883 is an integrated circuit to be applied on servo motor of radio controlled operation. It provides some flexible functions to tune the servo. External PNP driver will be chosen for servo motor application.

FEATURES

- Internal output NPN power transistor.
- Adjustable dead band range control by external capacitor.
- Fixed pulse width setting to provide start-up power and speed control
- Incorporates a protection circuit for "H-Bridge" driving configuration

APPLICATIONS

- Servo motor control.
- Radio controlled car, boat, and airplane.
- IA products (such as air-condition).
- Remote positioning.

BLOCK DIAGRAM

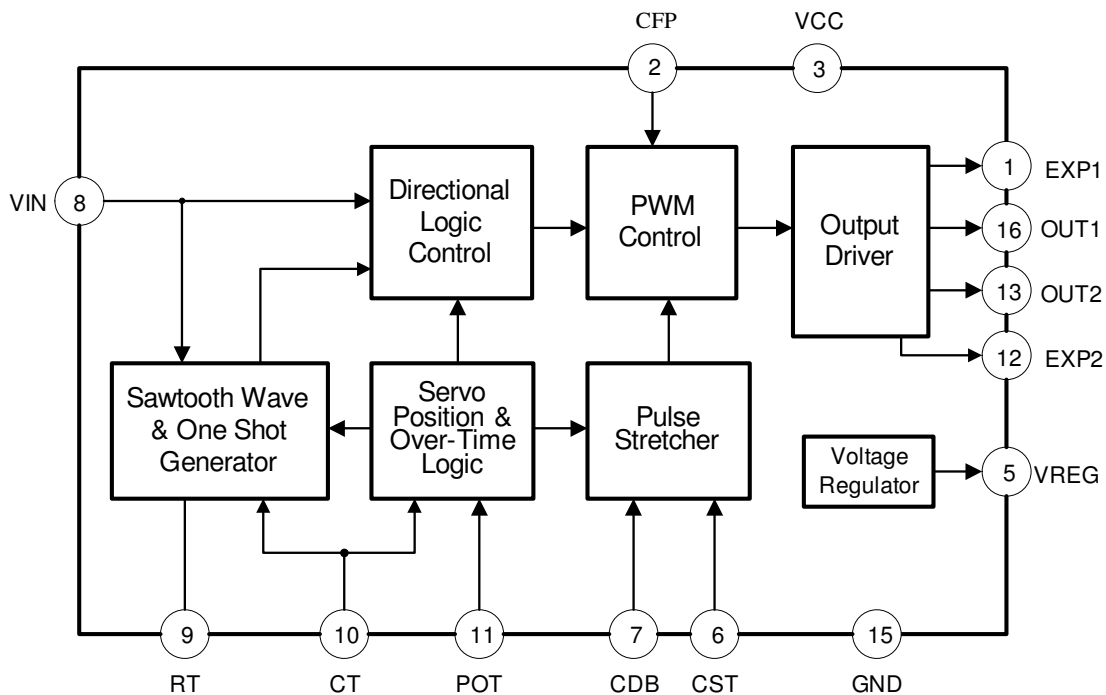

■ PIN DESCRIPTION

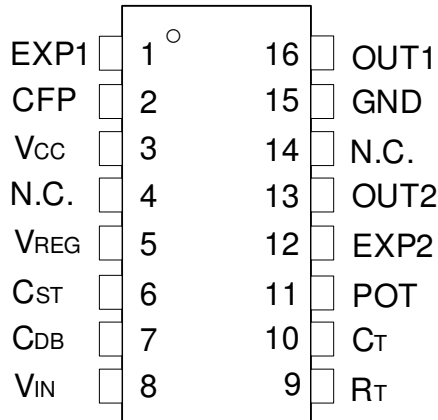

TOP VIEW

PIN NO.	PIN NAME	PIN FUNCTION
1	EXP1	Connect to the (Q1) base of the external PNP transistor
2	CFP	Fixed driving pulse setting
3	V _{CC}	Power supply pin
5	V _{REG}	Constant output voltage of 2.5V (typical). Make connections from this pin to a potentiometer or pulse stretcher resistor.
6	C _{ST}	Connect the capacitor and resistor of the pulse stretcher section.
7	C _{DB}	Dead band setting by connecting a capacitor.
8	V _{IN}	Input signal, an adjustable pulse of 20ms cycle and 1.0-2.0ms pulse-width, operate with a positive pulse of peak value 3V or greater.
9	R _T	Timing Resistor, connect a resistor that will determine the value of the constant current of this pin. A resistor of 18kΩ will yield a current of 1.0mA.
10	C _T	Local pulse setting, connect a capacitor that will generate a triangular wave by constant current charging.
11	POT	Servo position voltage from the potentiometer connected to the servo's drive shaft.
12	EXP2	Connect to the (Q2) base of the external PNP transistor
13	OUT2	Output Driver 2 (connect to motor)
15	GND	Ground pin
16	OUT1	Output Driver 1 (connect to motor)



■ ABSOLUTE MAXIMUM RATINGS

Ta=25°C

SYMBOL	PARAMETER	RATINGS	UNIT
Vcc	Supply voltage	9	V
IO	Output current	50	mA
Pd	Power dissipation	500	mW
Tstg	Storage temperature range	-40~125	°C

■ ELECTRICAL CHARACTERISTICS

Ta=25°C and Vcc=5V

SYMBOL	PARAMETER	CONDITIONS	LIMITS			UNIT
			MIN	TYP	MAX	
Vcc	Supply voltage		3.0	5	7.5	V
Icc	Operating current	When output is OFF	---	5	8	mA
		When output is ON	---	6	11	mA
V _{REG}	Regulator output voltage	Load capacitor 0.1uF	2.35	2.5	2.65	V
I _{REF}	Reference current	RT = 18 kΩ, Pin 5 current value	80	100	120	uA
V _{inH}	High input voltage	Pin4	3.0	---	Vcc	V
W _{SL}	Standard local pulse width	RT = 18 kΩ, CT = 0.1 uF	1.4	1.5	1.6	ms
W _{db1}	Minimum dead bandwidth	CFP = 0.01uF, Not connect CDB	---	---	1.0	us
W _{db2}	Standard driving band width	Not connect CFP and CDB	---	2.5	6.0	us
A _{STR}	Pulse Stretcher gain	RT=18 kΩ, RST=120 kΩ, CST=0.1 uF	---	100	---	times
W _{FP}	Fixed driving pulse width	CFP = 0.01uF, Not connect CDB	0.7	1.0	1.3	ms
W _{SDP}	Standard driving pulse width	Not connect CFP and CDB	0.3	0.5	0.8	ms
W _{op}	Output pulse width	CST = 0.1 uF, RST = 120 kΩ, Pulse width 100uS (3pin)	8.0	10.0	12.0	ms
V _{sat}	Output pin saturation voltage	I _{SINK} = 20 mA	---	0.2	0.4	V

APPLICATION CIRCUIT

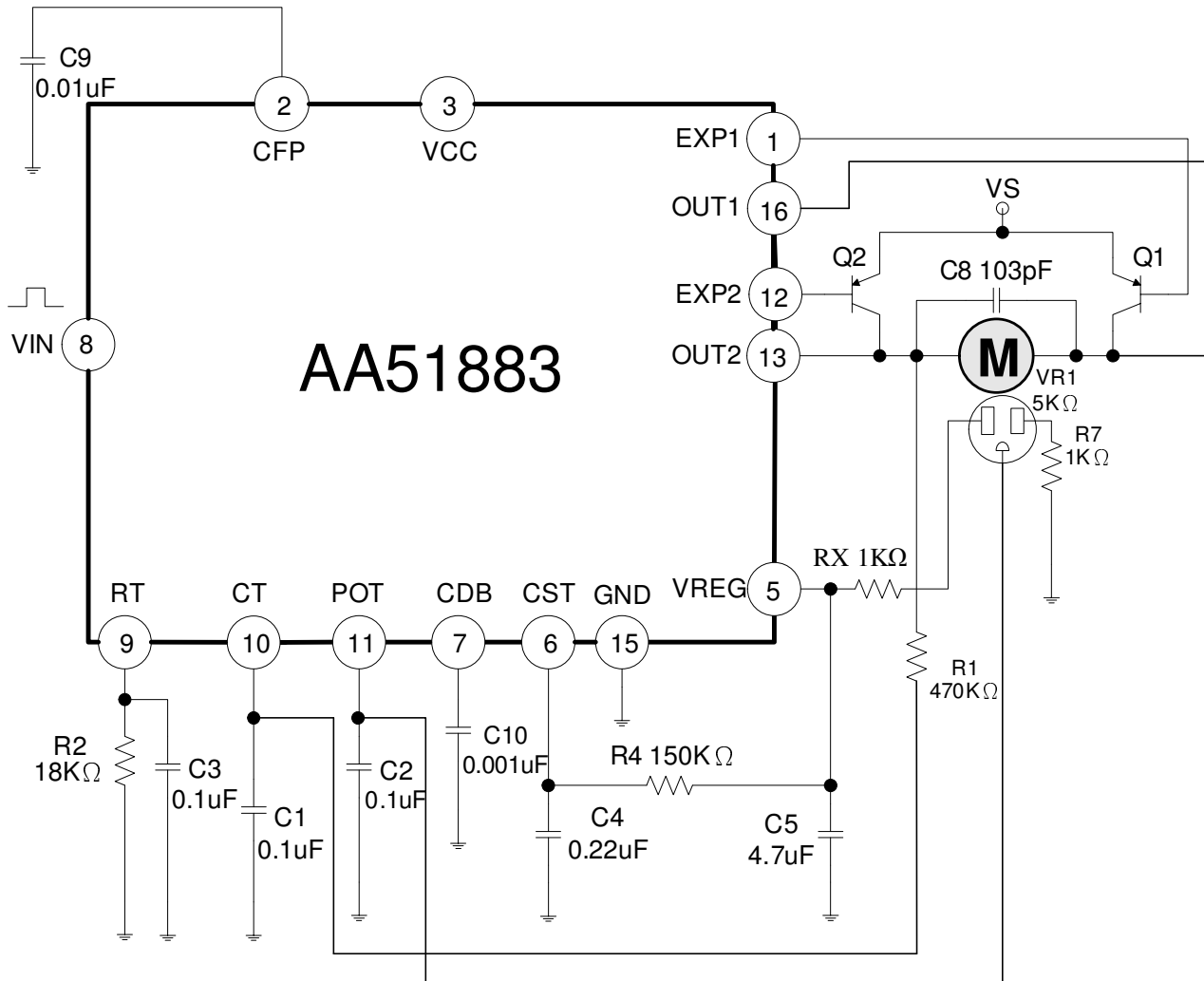

Half H-Bridge application using two external PNPs

When the servo is about to reach the target position, the servo maybe overshoot for speed issue. OUT1 and OUT2 pins are connected to both side of servo, you can try to reduce the value of R1 to let servo make an instant stop on the target position.

The application circuit is for reference only. The value of resistor and capacitor needs to be changed and gets the best performance in various servos.

**■ FUNCTIONAL DESCRIPTION****(1) Voltage Regulator**

This circuit is composed of a band gap circuit, and outputs a 2.5-volt temperature compensated reference voltage. This reference voltage is stabilized when the supply voltage is variable.

(2) Saw tooth wave & One-Shot Generator

Connect a capacitor to CT pin will generate a triangular wave by constant current charging. A typical value is 0.1 μ F. The constant current is determined by a resistor connected to RT pin. A typical capacitor of approximately 0.1 μ F should be connected in parallel with the resistor to increase stability.

(3) Servo Position & Over-Time logic

This circuitry consists of a pulse width comparator, which compares the servo position detection signal (POT pin) from the one-shot timer (CT pin) whose period depends on the resistance of a potentiometer connected to the servo's drive shaft. This feedback provides the stability for the control circuitry.

(4) Pulse Stretcher

The difference between the servo control signal and the feedback signal is the error signal. This error signal is used to toggle the direction of the current flows through the servo. The function of this pulse stretcher is to “stretch” the small error signal long enough and increases the duty cycle to the motor for it can maintain sufficient holding force. The circuit also implements a “dead band” function that prevents servo jitter and hunting. This is a range over which differences between the input and reference signals will not cause servo operation. When the signal differences exceed this “dead band” range, the servo will start to shift. The dead band will change according to the value of capacitor connected to the C_{DB} pin.

(5) Directional Logic Control

The comparator circuit compares pulses from the servo control input (VIN pin) and the voltage controlled pulse generator. It provides either a positive or a negative output depending on whether the signal pulse width is larger or smaller than the position generator's output pulse (POT pin). Application of this error voltage to the motor driver circuit causes the motor to turn in a direction that will minimize the error until both pulse widths are the same.

(6) PWM Control

This signal generated by directional logic control block is used to control a flip-flop that toggles the direction the current flows through the motor. The outputs of the flip-flop drive



an external H-Bridge output driver that handles the high current going through the motor. This output of this block will be turned on or off with each input pulse based on the status of the directional logic. The PWM drive techniques provide the benefits of reduced power dissipation, improved servo motor performance and positively affect system efficiency.

(7) Output driver

The output driver controls the servo current direction. For light load application, the servo can be connected with OUT1 and OUT2 pin only. For heavy load application, the EXP1 and EXP2 pin will be connected to the base of the external PNP transistor. It drives in an H-bridge configuration (The sink NPN drivers are built inside the chip).

■ NOTES ON USE

- The specifications for the product described in this document are for reference only. Upon actual use, therefore, please request that specifications to be separately delivered.
- The application circuit examples explain typical applications of the products, and do not guarantee the success of any specific mass-production design.
- Application circuit diagrams and circuit constants contained herein are shown as examples of standard use and operation. Please pay careful attention to the peripheral conditions when designing circuits and deciding upon circuit constants in the set.
- Take account of common impedance when designing the earth line on a printed wiring board.

■ ORDERING INFORMATION

ORDER NO.	PACKAGE	PACKING	Q'TY	MARK CHART
AA51883A	TSSOP 16L	TAPE & REEL	2,500ea	

PACKAGE DIMENSIONS

TSSOP 16L

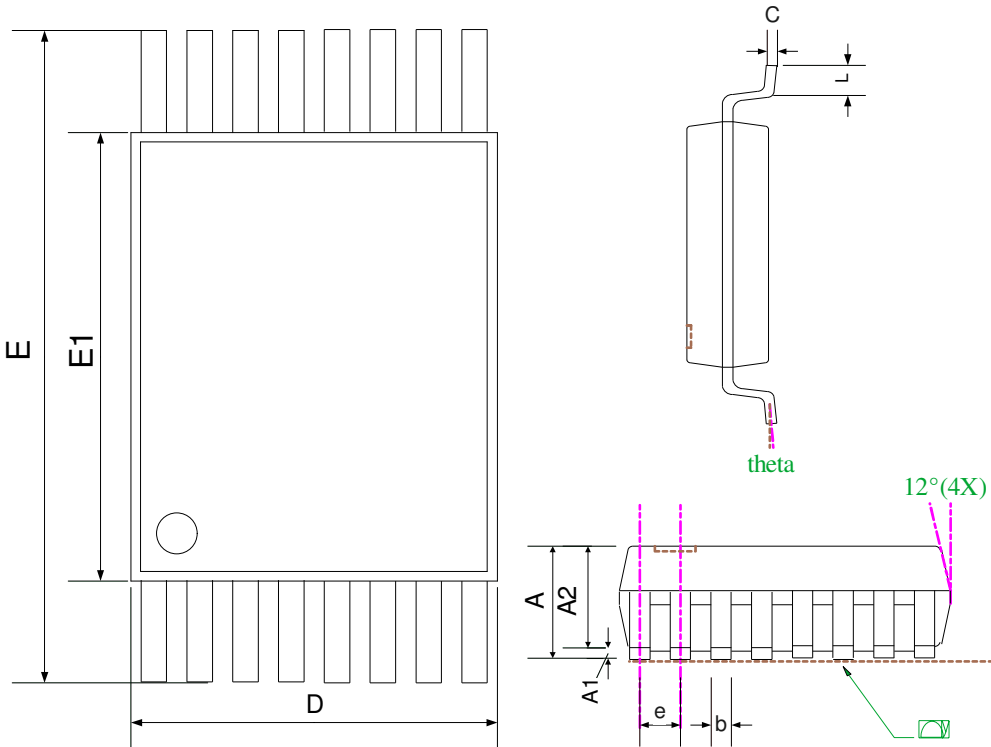

SYMBOLS	DIMENSIONS IN MILLIMETERS			DIMENSIONS IN INCHES		
	MIN	NOM	MAX	MIN	NOM	MAX
A	---	---	1.20	---	---	0.048
A1	0.05	---	0.15	0.002	---	0.006
A2	0.80	1.00	1.05	0.031	0.039	0.041
b	0.19	---	0.30	0.007	---	0.012
C	0.09	---	0.20	0.004	---	0.008
D	4.90	5.00	5.10	0.193	0.197	0.201
E	6.20	6.40	6.60	0.244	0.252	0.260
E1	4.30	4.40	4.50	0.169	0.173	0.177
e	---	0.65	---	---	0.026	---
L	0.45	0.60	0.75	0.018	0.024	0.030
y	---	---	0.10	---	---	0.004
theta	0°	---	8°	0°	---	8°

NOTE

1. PACKAGE BODY SIZES EXCLUDE MOLD FLASH PROTRUSION OR GATE BURRS
2. TOLERANCE +/- 0.1 mm UNLESS OTHERWISE SPECIFIED
3. COPLANARITY: 0.1 mm
4. CONTROLLING DIMENSION IS MILLIMETER CONVERTED INCH DIMENSIONS ARE NOT NECESSARILY EXACT
5. FOLLOWED FROM JEDEC MO-153