

**High Efficiency 1X/1.5X/2X Charge Pump for White LED Applications**

**General Description**

The AAT3141 is a low noise, constant frequency charge pump DC/DC converter that uses a tri-mode load switch (1X), fractional (1.5X), and doubling (2X) conversion to maximize efficiency for white LED applications. The device produces current levels up to 30mA on each of its four current source outputs to drive various arrangements of LEDs from a 2.7V to 5.5V input. Outputs may be operated individually or in parallel for driving higher-current LEDs. A low external parts count (two 1µF flying capacitors and two small 1µF capacitors at V<sub>IN</sub> and CP) make the AAT3141 ideally suited for small battery-powered applications.

The AAT3141 is equipped with Skyworks' unique AutoBias™ technology which allows individual LEDs to be powered either by charge pump or battery input, determined internally and automatically to maximize the power efficiency even with a large difference in LED forward voltage.

Skyworks' Advanced Simple Serial Control™ (AS<sup>2</sup>Cwire™) digital input is used to enable, disable, and set the LED drive current with a 32-level logarithmic scale LED brightness control. The AAT3141 has a thermal management system to protect the device in the event of a short-circuit condition at an output pin. Built-in soft-start circuitry prevents excessive inrush current during start-up. A high charge pump switching frequency enables the use of very small external capacitors. In shutdown mode, the device disconnects the load from V<sub>IN</sub> and reduces quiescent current to less than 1µA. The AAT3141 is available in the very small, Pb-free 12-pin TSOPJW package.

**Features**

- V<sub>IN</sub> Range: 2.7V to 5.5V
- Tri-Mode 1X, 1.5X, and 2X Charge Pump for Maximum Efficiency and V<sub>F</sub> Coverage
- Drives Low-V<sub>F</sub> and High-V<sub>F</sub> Type LEDs
- Up to Four 30mA Outputs
- AS<sup>2</sup>Cwire Independent 3+1 Output Addressing
- 32-Position Logarithmic Scale with Digital Control
- Low Noise Constant Frequency Operation
- 1MHz Switching Frequency
- AutoBias Technology
- Small Application Circuit
- Regulated Output Current
- Automatic Soft Start
- No Inductors
- I<sub>Q</sub> < 1µA in Shutdown
- 12-Pin TSOPJW Package

**Applications**

- Color (RGB) Lighting
- Programmable Current Sources
- White LED Backlighting
- White Photo Flash for Digital Still Cameras

**Typical Application**

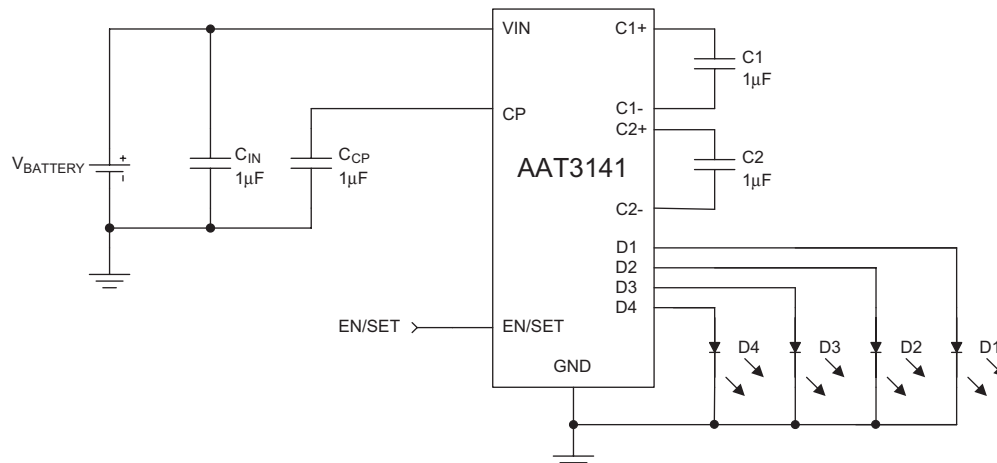

**AAT3141****High Efficiency 1X/1.5X/2X Charge Pump for White LED Applications****Pin Descriptions**

Pin #	Symbol	Function
1	C2+	Flying capacitor 2 positive terminal. Connect a 1 $\mu$ F capacitor between C2+ and C2-.
2	CP	Charge pump output. Requires 1 $\mu$ F capacitor connected between this pin and ground.
3	C1-	Flying capacitor 1 negative terminal.
4	C1+	Flying capacitor 1 positive terminal. Connect a 1 $\mu$ F capacitor between C1+ and C1-.
5	D3	Current source output #3.
6	D2	Current source output #2.
7	D4	Current source output #4.
8	D1	Current source output #1.
9	EN/SET	AS <sup>2</sup> Cwire serial interface control pin.
10	IN	Input power supply. Requires 1 $\mu$ F capacitor connected between this pin and ground.
11	GND	Ground.
12	C2-	Flying capacitor 2 negative terminal.

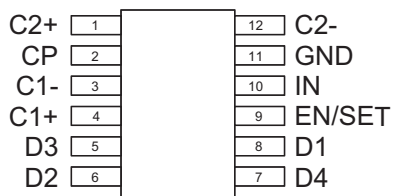
**Pin Configuration****TSOPJW-12  
(Top View)**

**High Efficiency 1X/1.5X/2X Charge Pump for White LED Applications****Absolute Maximum Ratings<sup>1</sup>**

Symbol	Description	Value	Units
$V_{IN}$	Input Voltage	-0.3 to 6	V
$V_{EN/SET}$	EN/SET to GND Voltage	-0.3 to $V_{IN} + 0.3$	V
$I_{OUT}^2$	Maximum DC Output Current	150	mA
$T_J$	Operating Junction Temperature Range	-40 to 150	°C

**Thermal Information<sup>3</sup>**

Symbol	Description	Value	Units
$P_D$	Maximum Power Dissipation <sup>4</sup>	625	mW
$\theta_{JA}$	Maximum Thermal Resistance	160	°C/W

1. Stresses above those listed in Absolute Maximum Ratings may cause permanent damage to the device. Functional operation at conditions other than the operating conditions specified is not implied. Only one Absolute Maximum Rating should be applied at any one time.

2. Based on long-term current density limitation.

3. Mounted on an FR4 board.

4. Derate 6.25mW/°C above 25°C.

## High Efficiency 1X/1.5X/2X Charge Pump for White LED Applications

Electrical Characteristics<sup>1</sup>

$C_{IN} = C_{CP} = C_1 = C_2 = 1.0\mu\text{F}$ ;  $T_A = -40^\circ\text{C}$  to  $+85^\circ\text{C}$ , unless otherwise noted. Typical values are at  $T_A = 25^\circ\text{C}$ ,  $V_{IN} = 3.5\text{V}$ .

Symbol	Description	Conditions	Min	Typ	Max	Units
<b>Input Power Supply</b>						
$V_{IN}$	Operation Range		2.7		5.5	V
$I_{CC}$	Operating Current	VD1:D4 = 2.0V, CP = 1X No Load Current, CP = 1.5X		550 3		$\mu\text{A}$ mA
$I_{SHDN}$	Shutdown Current	$V_{IN} = 3.5\text{V}$ , EN/SET = 0			1	$\mu\text{A}$
$I_{DX}$	Output Current Accuracy <sup>2</sup>	$V_{IN} = 3.5\text{V}$ , $T_A = 25^\circ\text{C}$ $V_{IN} = 3.5\text{V}$ , $T_A = 25^\circ\text{C}$ , Code 28	-10 17.1		10 20	% mA
$I_{(D-Match)}$	Current Matching <sup>3</sup>	VD1:D4 = 3.6V, $V_{IN} = 3.5\text{V}$	-3	$\pm 0.5$	3	%
$\eta_{CP}$	Charge Pump Section Efficiency	$V_{IN} = 3.5\text{V}$ , $I_{OUT(TOTAL)} = 120\text{mA}$ , Measured from IN to CP		93		%
<b>Charge Pump Section</b>						
$T_{SS}$	Soft-Start Time			50		$\mu\text{s}$
$F_{CLK}$	Clock Frequency			1		MHz
<b>EN/SET</b>						
$V_{EN(L)}$	Enable Threshold Low	$V_{IN} = 2.7\text{V}$			0.4	V
$V_{EN(H)}$	Enable Threshold High	$V_{IN} = 5.5\text{V}$	1.4			V
$T_{EN/SET LO}$	EN/SET Low Time		0.3		75	$\mu\text{s}$
$T_{EN/SET HI MIN}$	Minimum EN/SET High Time			50		ns
$T_{EN/SET HI MAX}$	Maximum EN/SET High Time				75	$\mu\text{s}$
$T_{OFF}$	EN/SET Off Timeout				500	$\mu\text{s}$
$T_{LAT}$	EN/SET Latch Timeout				500	$\mu\text{s}$
$I_{EN/SET}$	EN/SET Input Leakage	$V_{EN/SET} = 5.5\text{V}$ , $V_{IN} = 5.5\text{V}$	-1		1	$\mu\text{A}$

1. The AAT3141 is guaranteed to meet performance specifications over the  $-40^\circ\text{C}$  to  $+85^\circ\text{C}$  operating temperature range and is assured by design, characterization, and correlation with statistical process controls.

2. Codes 2 through 7 are guaranteed to be within  $\pm 15\%$  of stated current level.

3. Current matching is defined as  $I_{(D-Match)} = (I_D - I_{AVE})/I_{AVE}$ .

# AAT3141

## High Efficiency 1X/1.5X/2X Charge Pump for White LED Applications

### Typical Characteristics

Unless otherwise noted,  $V_{IN} = 3.5V$ ,  $C_{IN} = C_{CP} = C_1 = C_2 = 1\mu F$ ,  $T_A = 25^\circ C$ .

**Efficiency vs. Input Voltage**  
(Code 26)

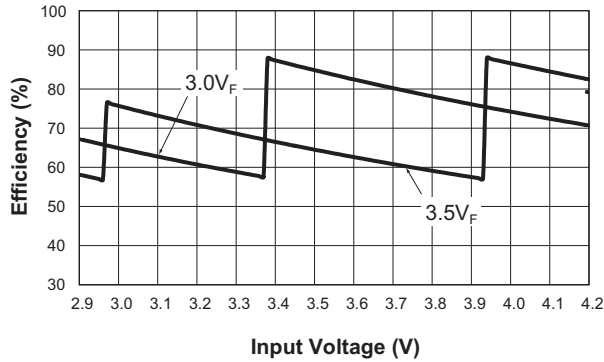

**Efficiency vs. Input Voltage**  
(D1 = 3.5V; D2 = 3.3V; D3 = 3.2V; D4 = 3.0V)

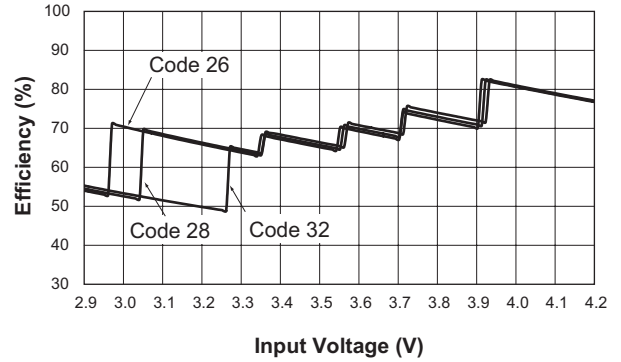

**Efficiency vs. Input Voltage**  
(D1-D2 = 3.5V; D3-D4 = 3.2V)

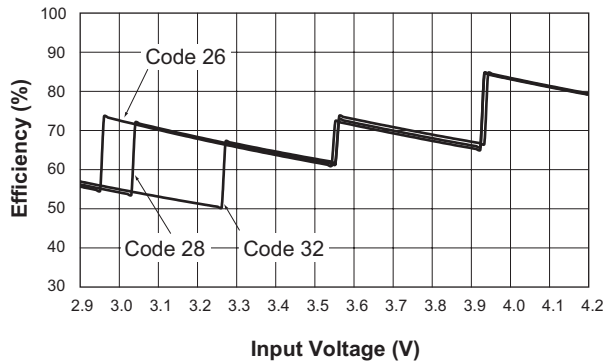

# AAT3141

## High Efficiency 1X/1.5X/2X Charge Pump for White LED Applications

### Typical Characteristics

Unless otherwise noted,  $V_{IN} = 3.5V$ ,  $C_{IN} = C_{CP} = C_1 = C_2 = 1\mu F$ ,  $T_A = 25^\circ C$ .

**Line Response**  
(1X Mode, 4x19mA Load)

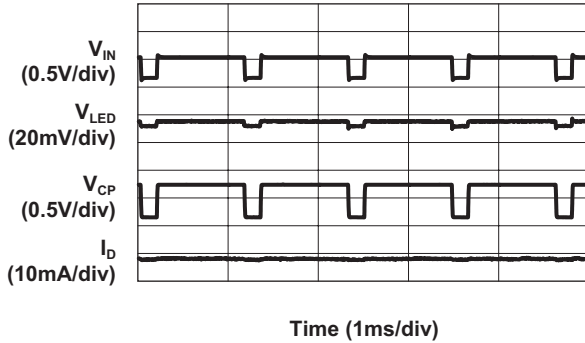

**Line Response**  
(1X Mode, 4x30mA Load)

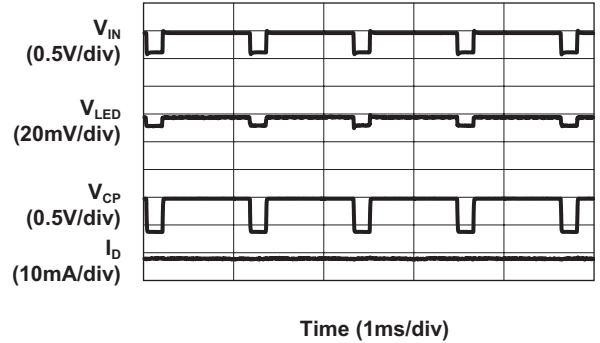

**Line Response**  
(1.5X Mode, 4x19mA Load)

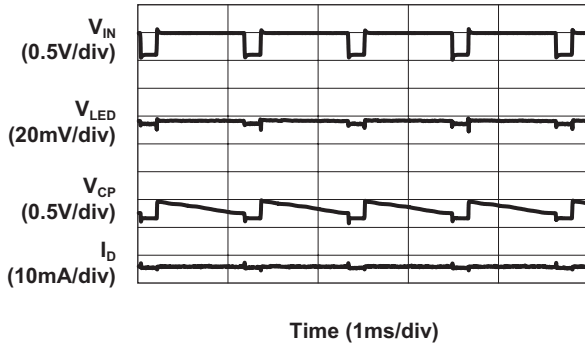

**Turn-On to 1.5X Mode**  
(4x30mA Load)

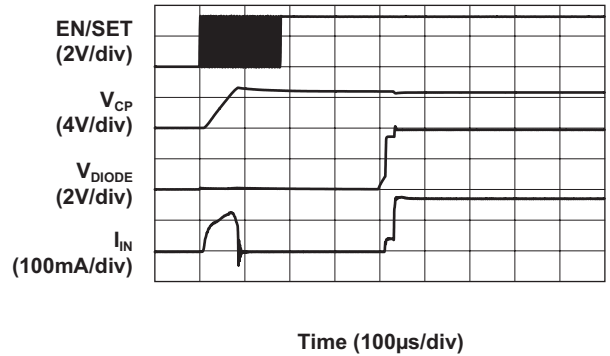

**Load Characteristics**  
(1.5X Mode, 4x15mA Load)

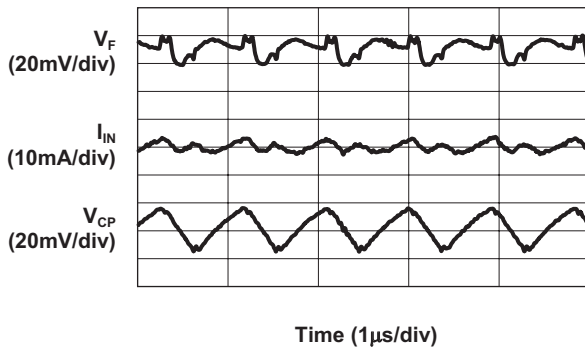

**Load Characteristics**  
(1.5X Mode, 4x30mA Load)

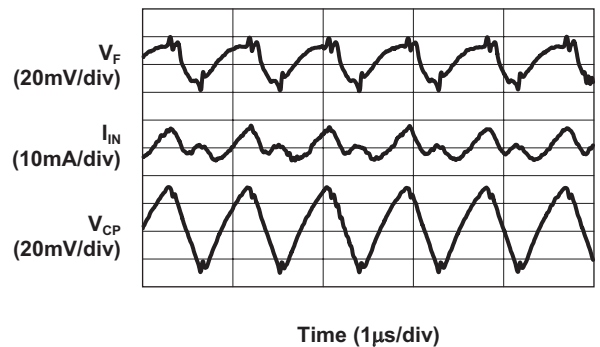

## High Efficiency 1X/1.5X/2X Charge Pump for White LED Applications

### Typical Characteristics

Unless otherwise noted,  $V_{IN} = 3.5V$ ,  $C_{IN} = C_{CP} = C_1 = C_2 = 1\mu F$ ,  $T_A = 25^\circ C$ .

**Charge Pump to Load Switch**  
(1.5X Mode, 4x19mA Load)

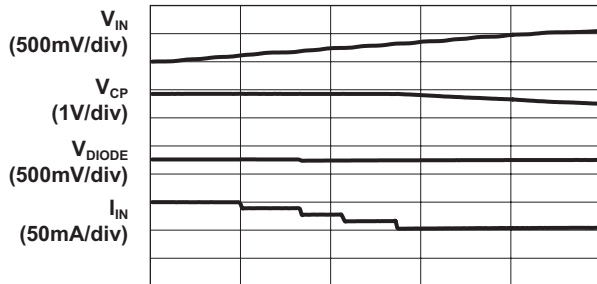

Time (5ms/div)

**Charge Pump to Load Switch**  
(1.5X Mode, 4x30mA Load)

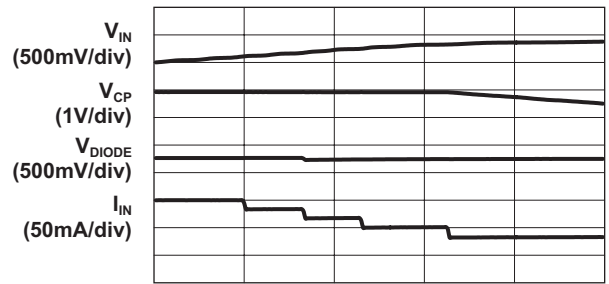

Time (5ms/div)

**Charge Pump to Load Switch**  
(2X Mode, 4x19mA Load)

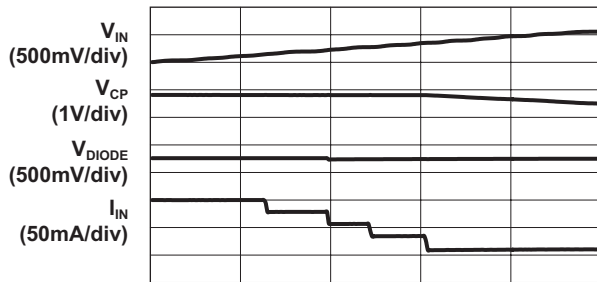

Time (5ms/div)

**Charge Pump to Load Switch**  
(2X Mode, 4x30mA Load)

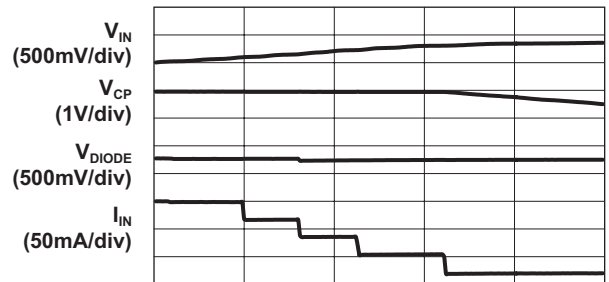

Time (5ms/div)

**Load Switch to Charge Pump**  
(1.5X Mode, 4x19mA Load)



Time (2ms/div)

**Load Switch to Charge Pump**  
(1.5X Mode, 4x30mA Load)

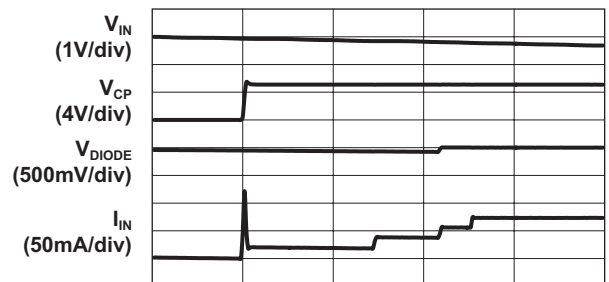

Time (2ms/div)

## High Efficiency 1X/1.5X/2X Charge Pump for White LED Applications

### Typical Characteristics

Unless otherwise noted,  $V_{IN} = 3.5V$ ,  $C_{IN} = C_{CP} = C_1 = C_2 = 1\mu F$ ,  $T_A = 25^\circ C$ .

**Turn-On to 1X Mode**  
(4x19mA Load)

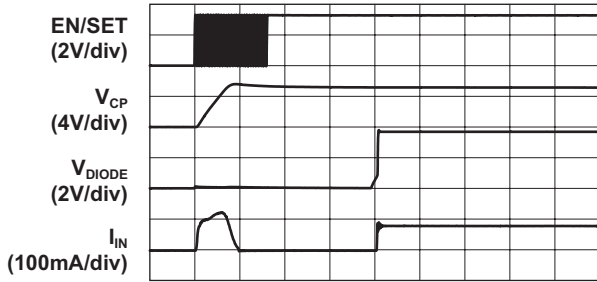

Time (100 $\mu$ s/div)

**Turn-On to 1X Mode**  
(4x30mA Load)

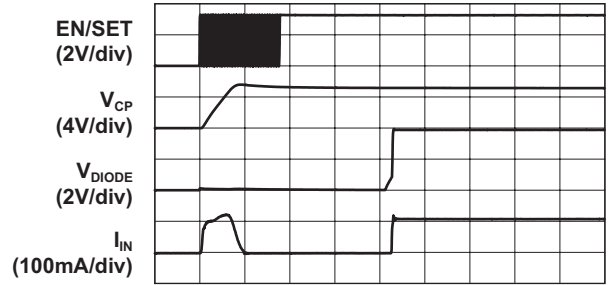

Time (100 $\mu$ s/div)

**Turn-On to 1.5X Mode**  
(4x19mA Load)

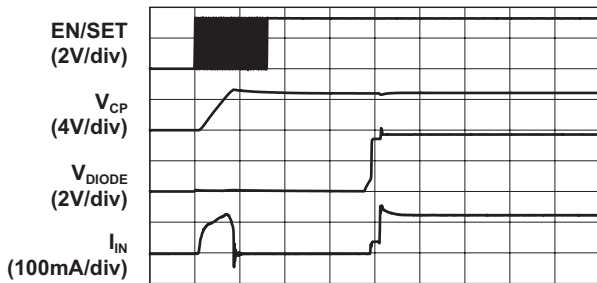

Time (100 $\mu$ s/div)

**Turn-On to 1.5X Mode**  
(4x30mA Load)

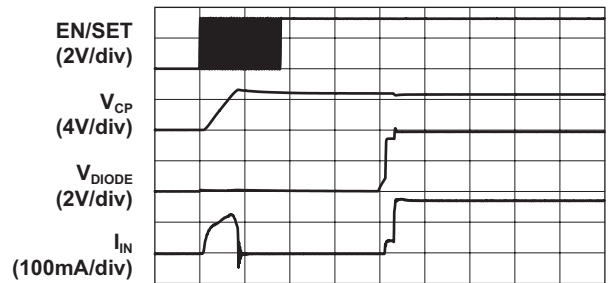

Time (100 $\mu$ s/div)

**Turn-Off from Full-Scale 2X Mode**

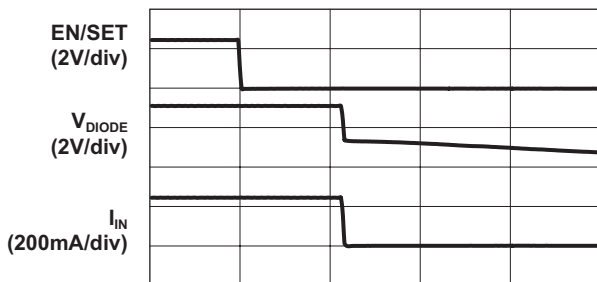

Time (100 $\mu$ s/div)



## High Efficiency 1X/1.5X/2X Charge Pump for White LED Applications

### Typical Characteristics

Unless otherwise noted,  $V_{IN} = 3.5V$ ,  $C_{IN} = C_{CP} = C_1 = C_2 = 1\mu F$ ,  $T_A = 25^\circ C$ .

**Input Current vs. Input Voltage  
(4x10mA)**

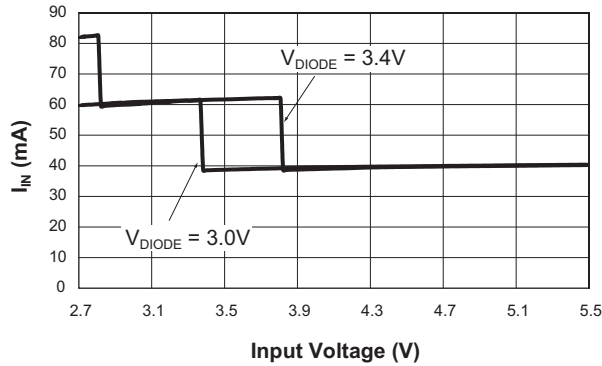

**Input Current vs. Input Voltage  
(4x30mA)**

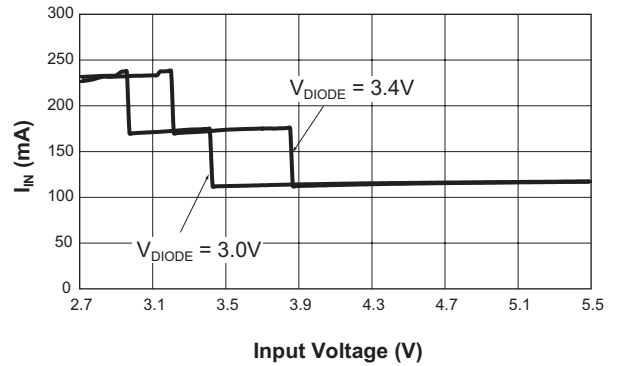

**Diode Current vs. Input Voltage  
(30mA, 15mA Settings)**

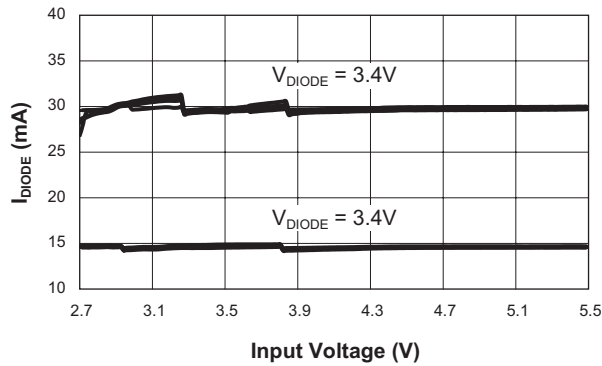

**$V_{IH}$  and  $V_{IL}$  vs.  $V_{IN}$**

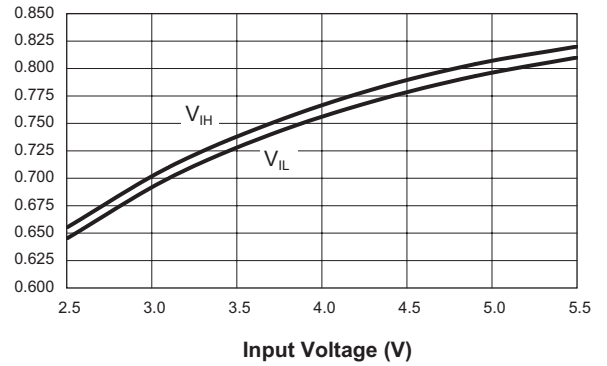

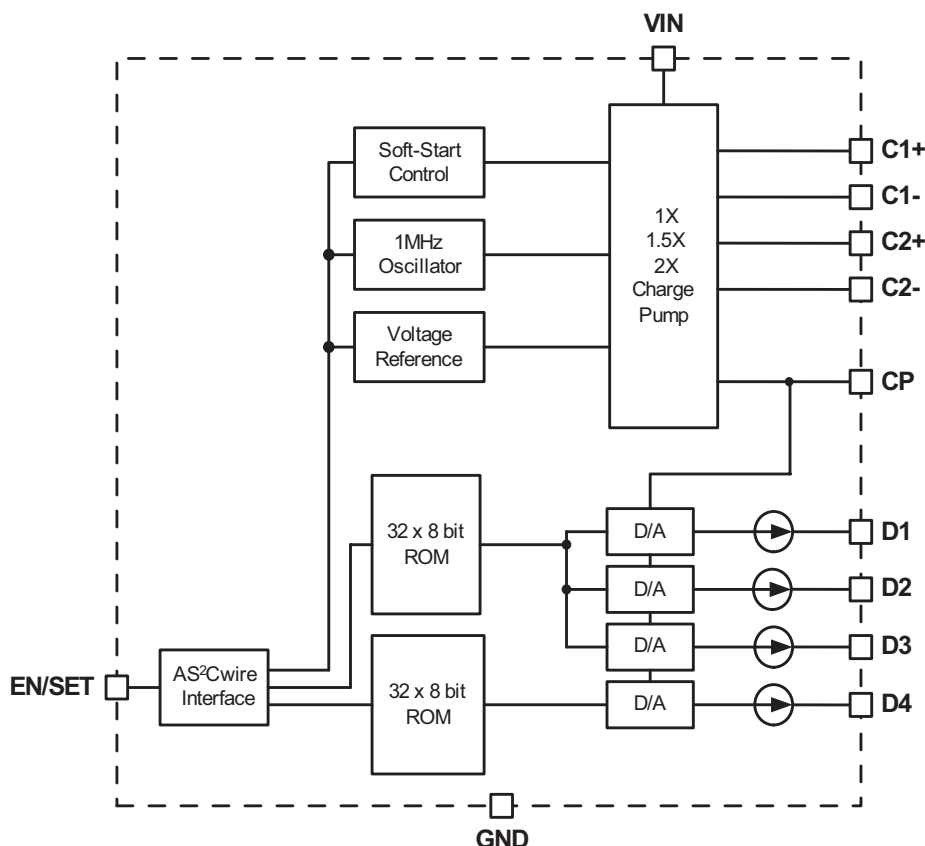
**High Efficiency 1X/1.5X/2X Charge Pump for White LED Applications****Functional Block Diagram****Functional Description**

The AAT3141 is a tri-mode load switch (1X) and high efficiency (1.5X or 2X) charge pump device intended for white LED backlight applications. To maximize power conversion efficiency, an internal sensing circuit monitors the voltage required on each constant current source output and sets the load switch and charge pump modes based on the input battery voltage and the current source output voltage. As the battery discharges over time, the AAT3141 charge pump is enabled when any of the four current source outputs nears dropout. The charge pump initially starts in 1.5X mode. If the charge pump output drops enough for any current source output to become close to dropout, the charge pump will automatically transition to 2X mode.

**AutoBias Technology**

Each of the four current source outputs is independently switched between the battery input (1X) or the charge pump output (1.5X or 2X), depending on the voltage at the current source output. Since the LED-to-LED forward voltage ( $V_F$ ) can vary as much as 1V, this function significantly enhances overall device efficiency when the battery input voltage level is greater than the voltage required at any current source output.

The AAT3141 requires only four external components: two  $1\mu\text{F}$  ceramic capacitors for the charge pump flying capacitors ( $C_1$  and  $C_2$ ), one  $1\mu\text{F}$  ceramic input capacitor ( $C_{IN}$ ), and one  $0.33\mu\text{F}$  to  $1\mu\text{F}$  ceramic charge pump output capacitor ( $C_{CP}$ ). The four constant current outputs (D1 to D4) drive four individual LEDs with a maximum current of 30mA each. The EN/SET AS<sup>2</sup>Cwire serial interface enables the AAT3141 and sets the current source magnitudes.

## High Efficiency 1X/1.5X/2X Charge Pump for White LED Applications

### Applications Information

#### Constant Current Output Level Settings

The constant current source amplitudes for D1 to D4 are set via the serial interface according to a logarithmic scale where each code is 1dB greater than the previous code. In this manner, LED brightness appears linear with each increasing code count. Because the outputs D1 to D4 are true independent constant current sources, the voltage observed on any single given output will be determined by the actual forward voltage ( $V_F$ ) for the LED being driven.

Since the output current of the AAT3141 is programmable, no PWM (pulse width modulation) or additional control circuitry are needed to control LED brightness. This feature greatly reduces the burden on a microcontroller or system IC to manage LED or display brightness, allowing the user to “set it and forget it.” With its high-speed serial interface (1MHz data rate), the output

current of the AAT3141 can be changed successively to brighten or dim LEDs in smooth transitions (e.g., to fade out) or in abrupt steps, giving the user complete programmability and real-time control of LED brightness.

The individual current level settings are each approximately 1dB apart for settings above Code 8 (see Figure 1). The current level settings below Code 8 are more than 1dB apart and serve the needs of transmissive displays and other low-current applications.

#### AS<sup>2</sup>Cwire Serial Interface

The current source output magnitude is controlled by the AS<sup>2</sup>Cwire serial digital input. AS<sup>2</sup>Cwire adds addressing capability for multiple data registers over the Simple Serial Control™ (S<sup>2</sup>Cwire™), which is only capable of controlling a single register. The AAT3141 has two registers. One contains the current level setting for outputs D1 to D3, and the other contains the current level setting for output D4.

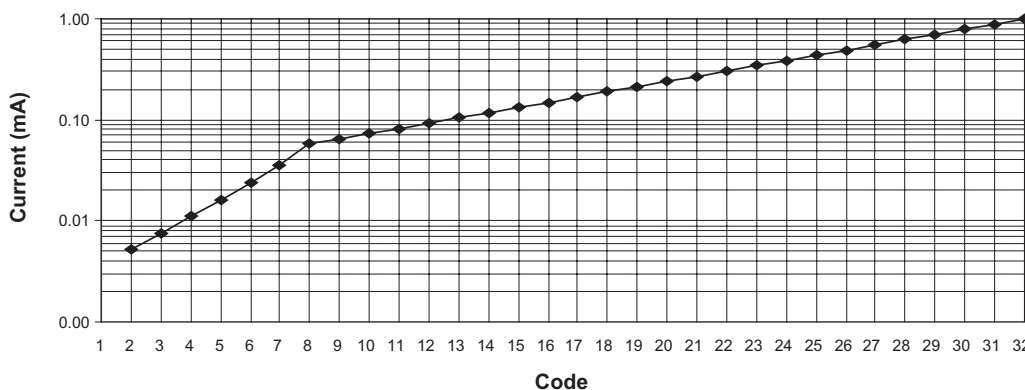

Figure 1: Normalized Current Level Settings.

Code	I <sub>OUT</sub> (typ) (mA)	Code	I <sub>OUT</sub> (typ) (mA)	Code	I <sub>OUT</sub> (typ) (mA)	Code	I <sub>OUT</sub> (typ) (mA)
1	0.0	9	2.0	17	5.1	25	13
2	0.1	10	2.2	18	5.6	26	15
3	0.2	11	2.5	19	6	27	17
4	0.4	12	2.8	20	7	28	19
5	0.5	13	3.2	21	8	29	21
6	0.7	14	3.5	22	9	30	24
7	1.1	15	4.0	23	10	31	27
8	1.8	16	4.5	24	12	32	30

Table 1: Constant Current Source Output Nominal Programming Levels.

**High Efficiency 1X/1.5X/2X Charge Pump for White LED Applications**

Three addresses are used to control the two registers. Address 0 addresses both registers simultaneously to allow the loading of both registers with the same data using a single write protocol. Address 1 addresses Register 1 for D1 to D3 current level settings. Address 2 addresses Register 2 for D4 current level settings.

As with S<sup>2</sup>Cwire, AS<sup>2</sup>Cwire relies on the number of rising edges of the EN/SET pin to address and load the registers. AS<sup>2</sup>Cwire latches data or address after the EN/SET pin has been held high for time  $T_{LAT}$ . Address or data is differentiated by the number of EN/SET rising edges. Since the data registers are 5 bits each, the differentiating number of pulses is 25 or 32, so that Address 0 is signified by 33 rising edges, Address 1 by 34 rising edges and Address 2 by 35 rising edges. Data is set to any number of rising edges between 1 and including 32. A typical write protocol is a burst of EN/SET rising edges, signifying a particular address, followed by a pause with EN/SET held high for the  $T_{LAT}$  timeout period, a burst of rising edges signifying data, and a  $T_{LAT}$  timeout for the data registers. Once an address is set, then multiple writes to the corresponding data register are allowed. Address 0 is the default address on the first rising edge after the AAT3141 has been disabled. If data is presented on the first rising edge with no prior address, both data registers are simultaneously loaded.

When EN/SET is held low for an amount of time greater than  $T_{OFF}$  the AAT3141 enters into shutdown mode and draws less than 1 $\mu$ A from  $V_{IN}$ . Data and address registers are reset to 0 during shutdown.

Address	EN/SET Rising Edges	Data Register
0	33	1 & 2: D1-D4
1	34	1: D1-D3
2	35	2: D4

**Table 2: AS<sup>2</sup>Cwire Serial Interface Addressing.**

### LED Selection

The AAT3141 is specifically intended for driving white LEDs. However, the device design will allow the AAT3141 to drive most types of LEDs with forward voltage specifications ranging from 1.0V to 4.3V. LED applications may include main and sub-LCD display backlighting, camera photo-flash applications, color (RGB) LEDs, infrared (IR) diodes for remotes, and other loads benefiting from a controlled output current generated from a varying input voltage. Since the D1 to D4 output current sources are matched with negligible voltage dependence, the LED brightness will be matched regardless of the specific LED forward voltage ( $V_F$ ) levels.

In some instances (e.g., in high luminous output applications such as photo flash), it may be necessary to drive high- $V_F$  type LEDs. The low-dropout current sources in the AAT3141 make it capable of driving LEDs with forward voltages as high as 4.3V at full current from an input supply as low as 3.0V. Outputs can be paralleled to drive high-current LEDs without complication.

### AS<sup>2</sup>Cwire Serial Interface Timing

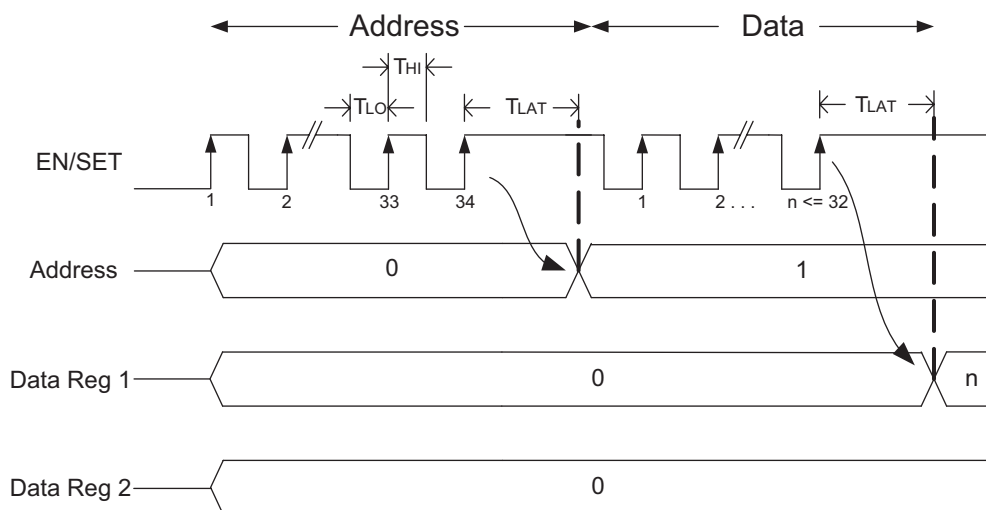

**High Efficiency 1X/1.5X/2X Charge Pump for White LED Applications****Termination of Unused Current Source Outputs**

If any outputs (D1 to D4) are not used, they should be terminated by connecting the respective unused output directly to ground. This is required to assure correct charge pump mode operation. If a given unused output is not terminated to ground, it will appear to the respective output's feedback control as an infinite impedance load and the unused constant current source will be set for a maximum voltage. Although no current flows from the unused current source, the voltage sensed at that node could force the charge pump control to activate the charge pump when it is not necessary. To prevent this effect, simply connect the unused constant current source outputs to ground.

**Device Switching Noise Performance**

The AAT3141 operates at a fixed frequency of approximately 1MHz to control noise and limit harmonics that can interfere with the RF operation of cellular telephone handsets or other communication devices. Back-injected noise appearing on the input pin of the charge pump is 20mV peak-to-peak, typically ten times less than inductor-based DC/DC boost converter white LED backlight solutions. The AAT3141 soft-start feature prevents noise transient effects associated with inrush currents during start-up of the charge pump circuit.

**Power Efficiency and Device Evaluation**

The charge pump efficiency discussion in the following sections only accounts for efficiency of the charge pump section itself. Due to the unique circuit architecture and design of the AAT3141, it is very difficult to measure efficiency in terms of a percent value comparing input power over output power.

Since the AAT3141 outputs are pure constant current sources and typically drive individual loads, it is difficult to measure the output voltage for a given output (D1 to D4) to derive an overall output power measurement. For any given application, white LED forward voltage levels can differ, yet the output drive current will be maintained as a constant.

This makes quantifying output power a difficult task when taken in the context of comparing to other white LED driver circuit topologies. A better way to quantify total device efficiency is to observe the total input power

to the device for a given LED current drive level. The best white LED driver for a given application should be based on trade-offs of size, external component count, reliability, operating range, and total energy usage...*not just % efficiency.*

The AAT3141 efficiency may be quantified under very specific conditions and is dependent upon the input voltage versus the output voltage seen across the loads applied to outputs D1 through D4 for a given constant current setting. Depending upon the case of  $V_{IN}$  being greater than the specific voltage seen across the load on D1 through D4, the device will operate in load switch mode. If the voltage seen on the constant current source output is less than  $V_{IN}$ , then the device will operate in 1.5X or 2X charge pump mode. Each of these modes will yield different efficiency values. Refer to the following two sections for explanations of each operational mode.

**Load Switch Mode Efficiency**

The AAT3141 load switch mode is operational at all times and functions alone to enhance device power conversion efficiency when  $V_{IN}$  is greater than voltage across the load connected to the constant current source outputs. When in load switch mode, the voltage conversion efficiency is defined as output power divided by input power:

$$\eta = \frac{P_{OUT}}{P_{IN}}$$

The expression to define the ideal efficiency ( $\eta$ ) can be rewritten as:

$$\eta = \frac{P_{OUT}}{P_{IN}} = \frac{V_{OUT} \cdot I_{OUT}}{V_{IN} \cdot I_{OUT}} = \frac{V_{OUT}}{V_{IN}}$$

-or-

$$\eta(\%) = 100 \left( \frac{V_{OUT}}{V_{IN}} \right)$$

**Charge Pump Section Efficiency**

The AAT3141 contains a fractional charge pump which will boost the input supply voltage when  $V_{IN}$  is less than the voltage required on the constant current source outputs. The efficiency ( $\eta$ ) can be simply defined as a linear voltage regulator with an effective output voltage that is

## High Efficiency 1X/1.5X/2X Charge Pump for White LED Applications

equal to one and one half or two times the input voltage. Efficiency ( $\eta$ ) for an ideal 1.5X charge pump can typically be expressed as the output power divided by the input power:

$$\eta = \frac{P_{OUT}}{P_{IN}}$$

In addition, with an ideal 1.5X charge pump, the output current may be expressed as 2/3 of the input current. The expression to define the ideal efficiency ( $\eta$ ) can be rewritten as:

$$\eta = \frac{P_{OUT}}{P_{IN}} = \frac{V_{OUT} \cdot I_{OUT}}{V_{IN} \cdot 1.5I_{OUT}} = \frac{V_{OUT}}{1.5V_{IN}}$$

-or-

$$\eta(\%) = 100 \left( \frac{V_{OUT}}{1.5V_{IN}} \right)$$

For a charge pump with an output of 5V and a nominal input of 3.5V, the theoretical efficiency is 95%. Due to internal switching losses and IC quiescent current consumption, the actual efficiency can be measured at 93%. These figures are in close agreement for output load conditions from 1mA to 100mA. Efficiency will decrease as load current drops below 0.05mA or when the level of  $V_{IN}$  approaches  $V_{OUT}$ . Refer to the Typical Characteristics section of this datasheet for measured plots of efficiency versus input voltage and output load current for the given charge pump output voltage options.

### Capacitor Selection

Careful selection of the four external capacitors  $C_{IN}$ ,  $C_1$ ,  $C_2$ , and  $C_{OUT}$  is important because they will affect turn-on time, output ripple, and transient performance. Optimum performance will be obtained when low equivalent series resistance (ESR) ceramic capacitors are used. In general, low ESR may be defined as less than 100m $\Omega$ . A value of 1 $\mu$ F for all four capacitors is a good starting point when choosing capacitors. If the LED current sources are only programmed for light current levels, then the capacitor size may be decreased.

### Capacitor Characteristics

Ceramic composition capacitors are highly recommended over all other types of capacitors for use with the AAT3141. Ceramic capacitors offer many advantages over their tantalum and aluminum electrolytic counterparts. A ceramic capacitor typically has very low ESR, is

lowest cost, has a smaller PCB footprint, and is non-polarized. Low ESR ceramic capacitors help maximize charge pump transient response. Since ceramic capacitors are non-polarized, they are not prone to incorrect connection damage.

### Equivalent Series Resistance

ESR is an important characteristic to consider when selecting a capacitor. ESR is a resistance internal to a capacitor that is caused by the leads, internal connections, size or area, material composition, and ambient temperature. Capacitor ESR is typically measured in milliohms for ceramic capacitors and can range to more than several ohms for tantalum or aluminum electrolytic capacitors.

### Ceramic Capacitor Materials

Ceramic capacitors less than 0.1 $\mu$ F are typically made from NPO or COG materials. NPO and COG materials have tight tolerance and are stable over temperature. Large capacitor values are composed of X7R, X5R, Z5U, or Y5V dielectric materials. Large ceramic capacitors, typically greater than 2.2 $\mu$ F, are often available in low-cost Y5V and Z5U dielectrics, but capacitors greater than 1 $\mu$ F are usually not required for AAT3141 applications.

Capacitor area is another contributor to ESR. Capacitors that are physically large will have a lower ESR when compared to an equivalent material smaller capacitor. These larger devices can improve circuit transient response when compared to an equal value capacitor in a smaller package size.

### Thermal Protection

The AAT3141 has a thermal protection circuit that will shut down the charge pump if the die temperature rises above the thermal limit, as is the case during a short-circuit of the CP pin.

### Charge Pump Compatibility

The four-output AAT3141 is pin-compatible with the AAT3123, AAT3132, and AAT3113 in TSOPJW-12 packages. The AAT3141 offers an improved overall efficiency, wider operating range, and the ability to drive high- $V_F$  type LEDs at full current. The AAT3141 is well suited for battery-powered applications using single-cell lithium-ion/polymer batteries and 3-series connected dry cells (3.6V).

**High Efficiency 1X/1.5X/2X Charge Pump for White LED Applications****Ordering Information**

Package	Marking <sup>1</sup>	Part Number (Tape and Reel) <sup>2</sup>
TSOPJW-12	LYXXY	<b>AAT3141ITP-T1</b>



Skyworks Green™ products are compliant with all applicable legislation and are halogen-free.

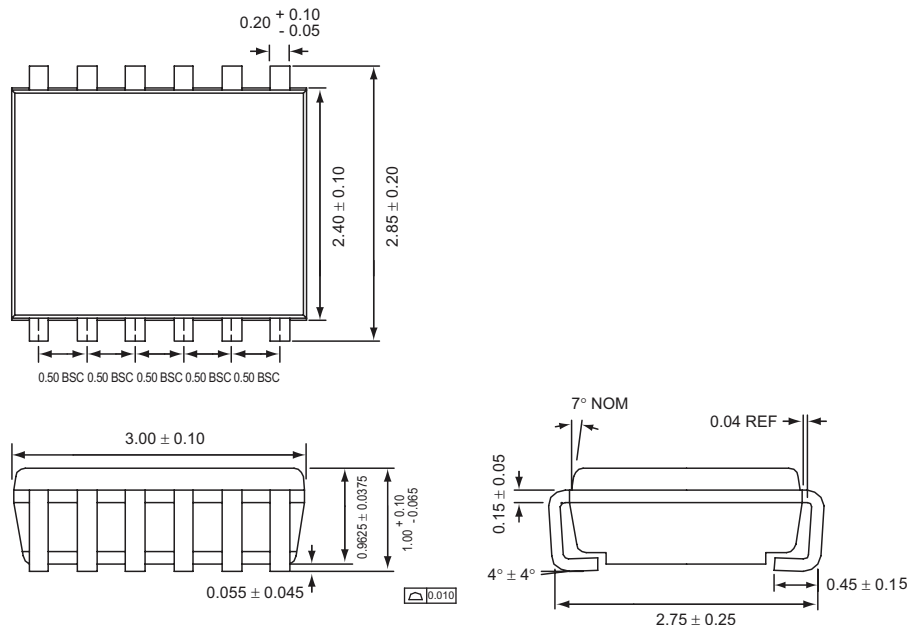

For additional information, refer to *Skyworks Definition of Green™*, document number SQ04-0074.

**Package Information****TSOPJW-12**

All dimensions in millimeters.

1. XYY = assembly and date code.
2. Sample stock is generally held on all part numbers listed in **BOLD**.

Copyright © 2012 Skyworks Solutions, Inc. All Rights Reserved.

Information in this document is provided in connection with Skyworks Solutions, Inc. ("Skyworks") products or services. These materials, including the information contained herein, are provided by Skyworks as a service to its customers and may be used for informational purposes only by the customer. Skyworks assumes no responsibility for errors or omissions in these materials or the information contained herein. Skyworks may change its documentation, products, services, specifications or product descriptions at any time, without notice. Skyworks makes no commitment to update the materials or information and shall have no responsibility whatsoever for conflicts, incompatibilities, or other difficulties arising from any future changes.

No license, whether express, implied, by estoppel or otherwise, is granted to any intellectual property rights by this document. Skyworks assumes no liability for any materials, products or information provided hereunder, including the sale, distribution, reproduction or use of Skyworks products, information or materials, except as may be provided in Skyworks Terms and Conditions of Sale.

THE MATERIALS, PRODUCTS AND INFORMATION ARE PROVIDED "AS IS" WITHOUT WARRANTY OF ANY KIND, WHETHER EXPRESS, IMPLIED, STATUTORY, OR OTHERWISE, INCLUDING FITNESS FOR A PARTICULAR PURPOSE OR USE, MERCHANTABILITY, PERFORMANCE, QUALITY OR NON-INFRINGEMENT OF ANY INTELLECTUAL PROPERTY RIGHT; ALL SUCH WARRANTIES ARE HEREBY EXPRESSLY DISCLAIMED. SKYWORKS DOES NOT WARRANT THE ACCURACY OR COMPLETENESS OF THE INFORMATION, TEXT, GRAPHICS OR OTHER ITEMS CONTAINED WITHIN THESE MATERIALS. SKYWORKS SHALL NOT BE LIABLE FOR ANY DAMAGES, INCLUDING BUT NOT LIMITED TO ANY SPECIAL, INDIRECT, INCIDENTAL, STATUTORY, OR CONSEQUENTIAL DAMAGES, INCLUDING WITHOUT LIMITATION, LOST REVENUES OR LOST PROFITS THAT MAY RESULT FROM THE USE OF THE MATERIALS OR INFORMATION, WHETHER OR NOT THE RECIPIENT OF MATERIALS HAS BEEN ADVISED OF THE POSSIBILITY OF SUCH DAMAGE.

Skyworks products are not intended for use in medical, lifesaving or life-sustaining applications, or other equipment in which the failure of the Skyworks products could lead to personal injury, death, physical or environmental damage. Skyworks customers using or selling Skyworks products for use in such applications do so at their own risk and agree to fully indemnify Skyworks for any damages resulting from such improper use or sale.

Customers are responsible for their products and applications using Skyworks products, which may deviate from published specifications as a result of design defects, errors, or operation of products outside of published parameters or design specifications. Customers should include design and operating safeguards to minimize these and other risks. Skyworks assumes no liability for applications assistance, customer product design, or damage to any equipment resulting from the use of Skyworks products outside of stated published specifications or parameters.

Skyworks, the Skyworks symbol, and "Breakthrough Simplicity" are trademarks or registered trademarks of Skyworks Solutions, Inc., in the United States and other countries. Third-party brands and names are for identification purposes only, and are the property of their respective owners. Additional information, including relevant terms and conditions, posted at [www.skyworksinc.com](http://www.skyworksinc.com), are incorporated by reference.