

## General Description

The AAT3526/7/8 PowerManager products are members of AnalogicTech's Total Power Management IC™ (TPMIC™) product family. These microprocessor reset circuits are ideal for monitoring voltage supplies in portable systems, where extended battery life is critical. They provide a reliable, low-cost solution by eliminating external components. The AAT3526/7/8 products operate by monitoring the system power supply voltage. When the input voltage drops below a fixed threshold, the device asserts a reset signal for a minimum of 150ms after  $V_{CC}$  has risen back above the fixed threshold. They are guaranteed to operate down to 1.2V and designed to ignore fast line transients appearing on  $V_{CC}$ . The AAT3526/7/8 series is available with three output stage versions: AAT3526 push-pull active low output; AAT3527 push-pull active high output; and AAT3528 open drain active low output. The quiescent supply current is extremely low, typically 1 $\mu$ A, making this device ideal for portable battery-operated equipment.

AAT3526/7/8 devices are available in a Pb-free, 4-pin SOT143 package and are specified over the -40°C to +85°C operating temperature range.

## Features

- Input Voltage Range: 1.2V to 5.5V
- Operation Down to 1.2V
- Extremely Low Quiescent Current: Less Than 2 $\mu$ A
- High Accuracy Detection Threshold:  $\pm 1.5\%$
- Monitor Power Supply Voltages
- Fixed Thresholds From 2.2V to 4.6V
- Minimum 150ms Reset Pulse Width With Fast Delay Time <20 $\mu$ s
- Debounced Manual Reset Input
- Available Output Configurations:
  - Open-Drain Output
  - CMOS Active High Output
  - CMOS Active Low Output
- Temperature Range: -40°C to +85°C
- 4-Pin SOT143 Package
- 4kV ESD Rating

## Applications

- Cell Phones
- Embedded Systems
- Intelligent Instruments
- Notebook Computers
- Portable Electronics

## Typical Application

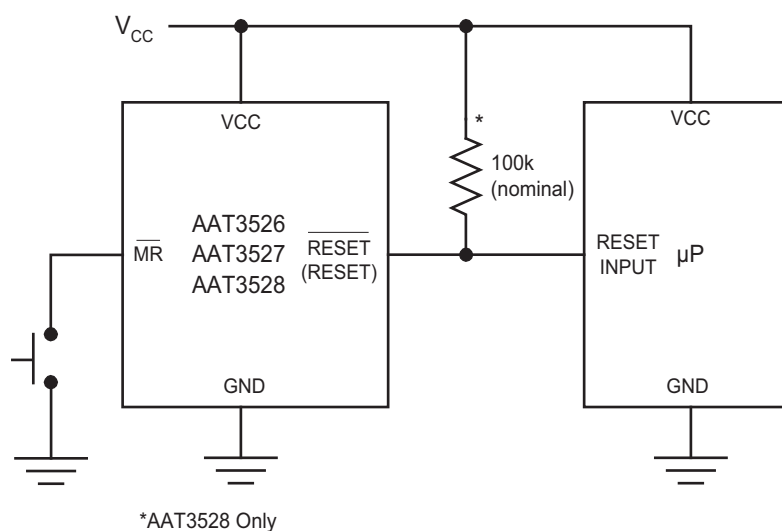

## Pin Descriptions

| Pin # | Symbol   | Function   |
|-------|--|--|
| 1     | GND  | Ground connection.   |
| 2     | RESET<br>(AAT3527)                                 | RESET output remains high while $V_{CC}$ is below the reset threshold and remains so for a minimum of 150ms after $V_{CC}$ raises above the reset threshold.   |
|       | $\overline{\text{RESET}}$<br>(AAT3526,<br>AAT3528) | $\overline{\text{RESET}}$ output remains low while $V_{CC}$ is below the reset threshold and remains so for a minimum of 150ms after $V_{CC}$ raises above the reset threshold.  |
| 3     | $\overline{\text{MR}}$                             | Manual reset active low input. A logic low signal on $\overline{\text{MR}}$ asserts a reset condition. Asserted reset continues as long as $\overline{\text{MR}}$ is low and for a minimum of 150ms after $\overline{\text{MR}}$ returns high. |
| 4     | VCC  | Supply voltage (+1.2V to +5.5V). Due to extremely low operating current, it is recommended to place a 10nF capacitor between $V_{CC}$ and GND.   |

## Part Number Descriptions

| Part Number | Output Type                                   |
|-------------|---|
| AAT3526     | Reset Output Push Pull Active Low with Delay  |
| AAT3527     | Reset Output Push Pull Active High with Delay |
| AAT3528     | Reset Output Open Drain Active Low with Delay |

## Pin Configuration

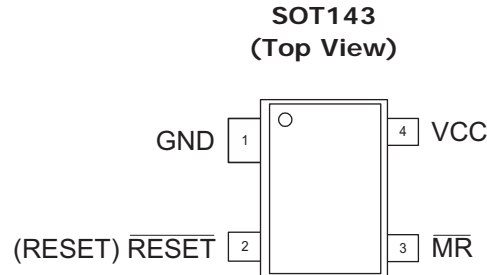

## Absolute Maximum Ratings<sup>1</sup>

T<sub>A</sub> = 25°C, unless otherwise noted.

| Symbol                             | Description                                      | Value                         | Units |
|------------------------------------|--|-------------------------------|-------|
| V <sub>CC</sub>                    | V <sub>CC</sub> to GND                           | -0.3 to 5.5                   | V     |
| V <sub>MR</sub>                    | MR to GND  | -0.3 to V <sub>CC</sub> + 0.3 | V     |
| V <sub>RESET</sub>                 | RESET to GND (Push-Pull Output)                  | -0.3 to V <sub>CC</sub> + 0.3 | V     |
|                                    | RESET to GND (Open Drain Output)                 | -0.3 to 5.5                   |       |
| I <sub>VCC</sub> , I <sub>MR</sub> | Maximum Continuous Input Current                 | 20                            | mA    |
| I <sub>RESET</sub>                 | RESET/RESET Current                              | 20                            | mA    |
| dV <sub>CC</sub> /dt               | Rate of Rise of V <sub>CC</sub>                  | 100                           | V/μs  |
| T <sub>J</sub>                     | Operating Junction Temperature Range             | -40 to 150                    | °C    |
| T <sub>LEAD</sub>                  | Maximum Soldering Temperature (at Leads) for 10s | 300                           | °C    |

## Thermal Information<sup>2</sup>

| Symbol          | Description                | Value | Units |
|-----------------|----------------------------|-------|-------|
| Θ <sub>JA</sub> | Maximum Thermal Resistance | 200   | °C/W  |
| P <sub>D</sub>  | Maximum Power Dissipation  | 320   | mW    |

1. Stresses above those listed in Absolute Maximum Ratings may cause permanent damage to the device. Functional operation at conditions other than the operating conditions specified is not implied. Only one Absolute Maximum Rating should be applied at any one time.  
 2. Mounted on an FR4 board.

## Electrical Characteristics

$V_{IN} = 5V$ ,  $T_A = -40^{\circ}C$  to  $+85^{\circ}C$ , unless otherwise noted. Typical values are  $T_A = 25^{\circ}C$ ,  $V_{CC} = 5V$  for 4.63/4.38V versions,  $V_{CC} = 3.3V$  for 3.08/2.93V versions,  $V_{CC} = 3.0V$  for 2.63V versions, and  $V_{CC} = 2.5V$  for 2.32/2.2V versions.

| Symbol                    | Description                                  | Conditions  | Min                | Typ      | Max                 | Units            |
|---------------------------|--|---|--------------------|----------|---------------------|------------------|
| $V_{CC}$                  | Operation Voltage                            | $T_A = 0^{\circ}C$ to $+70^{\circ}C$  | 1.0                |          | 5.5                 | V                |
|                           |  | $T_A = -40^{\circ}C$ to $+85^{\circ}C$  | 1.2                |          | 5.5                 |                  |
| $I_Q$                     | Quiescent Current                            | $V_{CC} = 5.5V$   |                    | 1.05     | 3                   | $\mu A$          |
|                           |  | $V_{CC} = 3V$   |                    | 0.85     | 2                   |                  |
| $V_{TH}$                  | RESET Threshold <sup>1</sup>                 | $T_A = 25^{\circ}C$   | $V_{TH} - 1.5\%$   | $V_{TH}$ | $V_{TH} + 1.5\%$    | V                |
|                           |  | $T_A = -40^{\circ}C$ to $+85^{\circ}C$  | $V_{TH} - 2.5\%$   | $V_{TH}$ | $V_{TH} + 2.5\%$    |                  |
| $\Delta V_{TH}/^{\circ}C$ | RESET Threshold Tempco                       |   |                    | 40       |                     | ppm/ $^{\circ}C$ |
| $t_P$                     | RESET Propagation Delay                      | $V_{CC} = V_{TH}$ to $(V_{TH} - 100mV)$   |                    | 15       |                     | $\mu s$          |
| $t_{RDY}$                 | RESET Active Timeout Period                  |   | 150                | 250      | 400                 | ms               |
| $t_{MR}$                  | MR Minimum Pulse Width                       |   | 10                 |          |                     | $\mu s$          |
| MARGI                     | MR Glitch Immunity                           |   |                    | 100      |                     | ns               |
| $t_{MD}$                  | MR to Reset Propagation Delay                |   |                    | 0.5      |                     | $\mu s$          |
| $V_{IH}$                  | MR Input Threshold (High)                    | $V_{CC} = V_{TH(MAX)}$ , $V_{TH} \geq 4.38V$  | 2.3                |          |                     | V                |
|                           |  | $V_{CC} = V_{TH(MAX)}$ , $V_{TH} < 4.38V$   | $0.7 \cdot V_{CC}$ |          |                     |                  |
| $V_{IL}$                  | MR Input Threshold (Low)                     | $V_{CC} = V_{TH(MAX)}$ , $V_{TH} \geq 4.38V$  |                    |          | 0.8                 | V                |
|                           |  | $V_{CC} = V_{TH(MAX)}$ , $V_{TH} < 4.38V$   |                    |          | $0.25 \cdot V_{CC}$ |                  |
| $R_{MR}$                  | MR Pull-Up Resistance                        |   | 30                 | 65       | 90                  | k $\Omega$       |
| $V_{OL}$                  | RESET Low Output Voltage<br>AAT3526, AAT3528 | $I_{SINK} = 1.2mA$ , $V_{CC} = V_{TH(min)}$ , $V_{TH} \leq 3.08V$ ,<br>RESET Asserted     |                    |          | 0.3                 | V                |
|                           |  | $I_{SINK} = 3.2mA$ , $V_{CC} = V_{TH(min)}$ , $V_{TH} > 3.08V$ ,<br>RESET Asserted        |                    |          | 0.4                 |                  |
| $V_{OH}$                  | RESET High Output Voltage<br>AAT3526         | $I_{SOURCE} = 800\mu A$ , $V_{TH} > 3.08V$ , $V_{CC} > V_{TH(max)}$                       | $V_{CC} - 1.5$     |          |                     | V                |
|                           |  | $I_{SOURCE} = 500\mu A$ , $V_{TH} \leq 3.08V$ , $V_{CC} > V_{TH(max)}$                    | $0.8 V_{CC}$       |          |                     |                  |
| $V_{OL}$                  | RESET Low Output Voltage<br>AAT3527          | $I_{SINK} = 1.2mA$ , $V_{CC} > V_{TH(max)}$ , $V_{TH} \leq 3.08V$ ,<br>RESET Not Asserted |                    |          | 0.3                 | V                |
|                           |  | $I_{SINK} = 3.2mA$ , $V_{CC} > V_{TH(max)}$ , $V_{TH} > 3.08V$ ,<br>RESET Not Asserted    |                    |          | 0.4                 |                  |
| $V_{OH}$                  | RESET High Output Voltage<br>AAT3527         | $I_{SOURCE} = 500\mu A$ , $V_{CC} > 2.1V$ , RESET Asserted                                | $0.8V_{CC}$        |          |                     | V                |
|                           |  | $I_{SOURCE} = 50\mu A$ , $V_{CC} > 1.2V$ , RESET Asserted                                 | $0.8V_{CC}$        |          |                     |                  |
| $I_{DOFF}$                | RESET Leakage Current,<br>AAT3528            | $V_{CC} > V_{TH}$   |                    |          | 1                   | $\mu A$          |

1. See Ordering Information for factory-trimmed reset thresholds.

## Typical Characteristics

**Supply Current vs. Temperature**

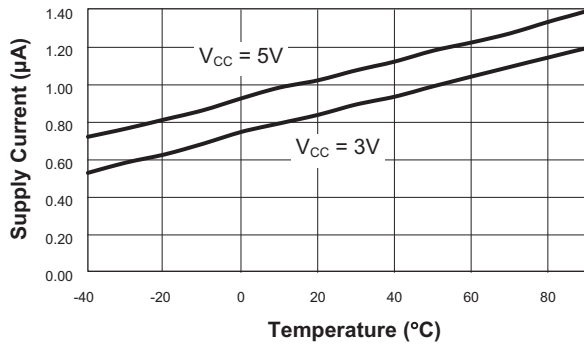

**Normalized Reset Threshold vs. Temperature**

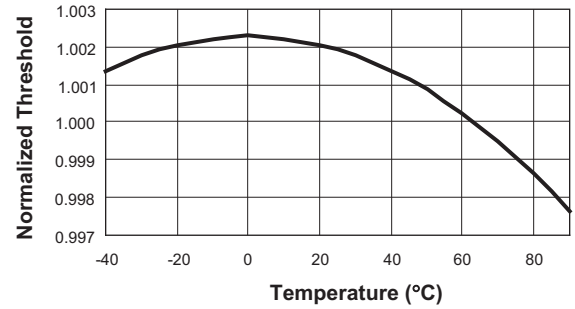

**Power-Up Reset Timeout vs. Temperature**

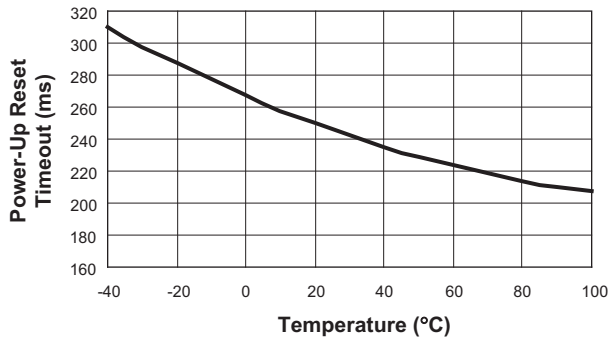

**Power-Down Reset Propagation Delay vs. Temperature**

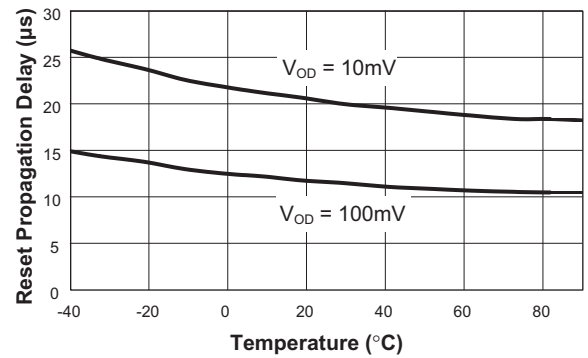

**Maximum Transient Duration vs. Reset Threshold Overdrive**

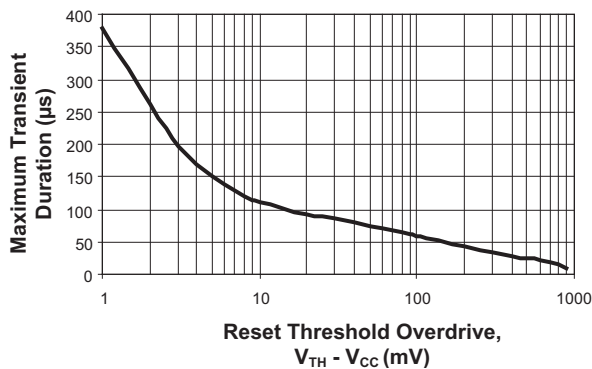

## Functional Block Diagram

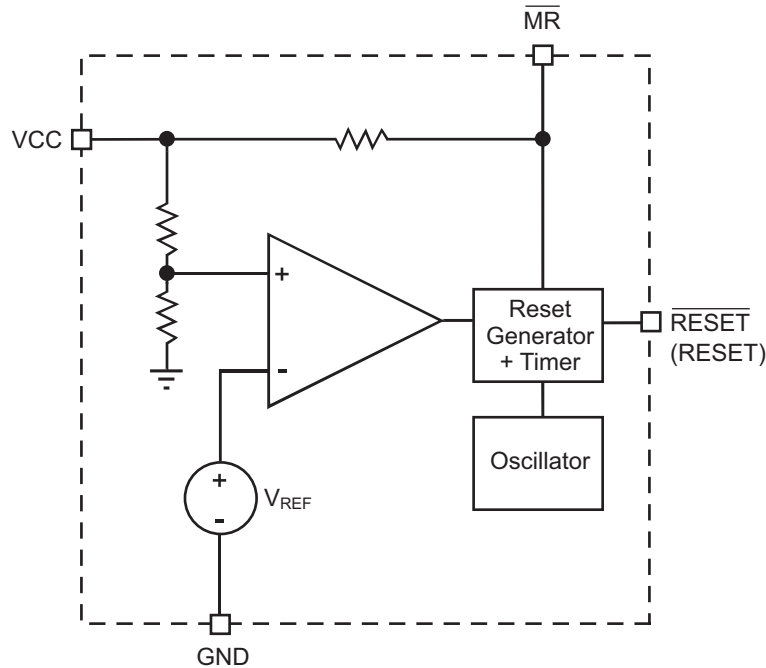

## Functional Description

During start-up, the reset pin on a microprocessor ensures that it is fully reset and starts up in a known condition. The AAT3526/7/8 series of microprocessor reset devices monitor the supply voltage to a microprocessor and assert a reset signal whenever the  $V_{CC}$  voltage falls below a factory-programmed threshold. This threshold is accurate within  $\pm 1.5\%$  at  $25^\circ\text{C}$  and within  $\pm 2.5\%$  over the entire operating temperature range. The reset signal remains asserted for a minimum of 150ms after  $V_{CC}$  has risen above the threshold, as shown in Figure 1.

## Applications Information

### Reset Output Options

The AAT3528 has an active low open drain output and the AAT3526/7 have a push-pull output. The AAT3528 may be used in multiple voltage systems with an external pull-up resistor. This allows the AAT3528 to interface to microprocessors with higher supply voltages up to 5.5V (Figure 2). In the event of a power-down or brown-out condition, the reset signal remains valid until the  $V_{CC}$  drops below 1.2V. To ensure validity down to ground, an external  $100\text{k}\Omega$  resistor should be connected between the RESET output and GND.

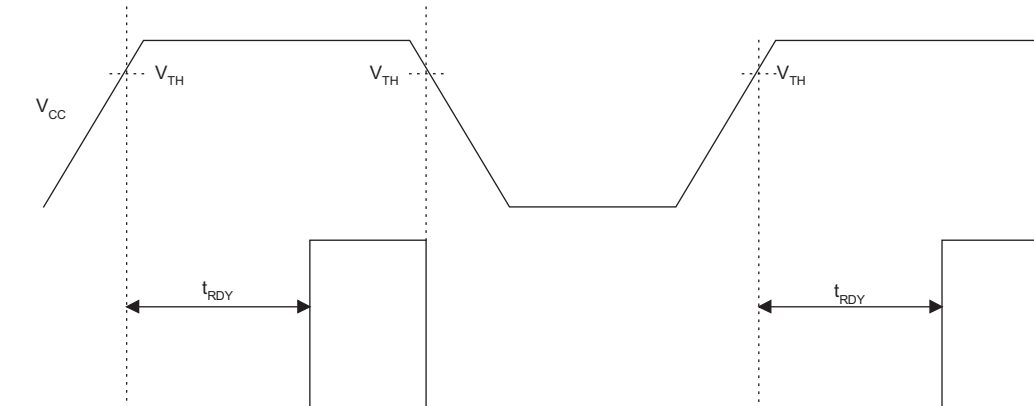
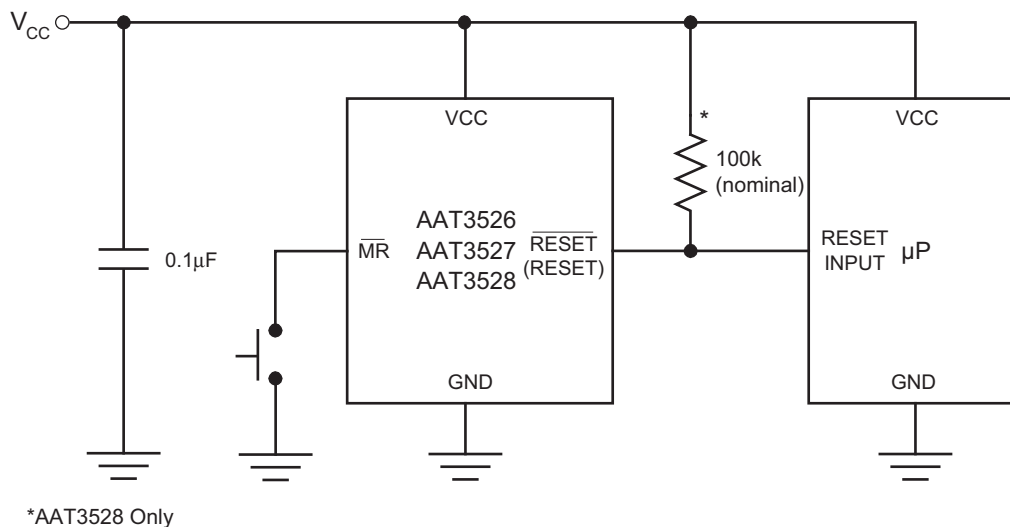

**Figure 1: Reset Timing Diagram.**

### Manual Reset Input

A logic low signal on  $\overline{\text{MR}}$  asserts a reset condition. Reset continues to be asserted as long as  $\overline{\text{MR}}$  is low and for a minimum of 150ms after  $\overline{\text{MR}}$  returns high. This input is internally pulled up to  $V_{\text{CC}}$  via a 65k $\Omega$  resistor, so leaving the pin unconnected is acceptable if the manual reset function is not needed. The  $\overline{\text{MR}}$  input is internally debounced which allows the use of a mechanical switch. It should be a normally-open momentary switch connected from  $\overline{\text{MR}}$  to GND. Additionally, the  $\overline{\text{MR}}$  pin can be driven from TTL, CMOS, or open drain logic outputs.

### Supply Voltage Transient Behavior

In some cases, fast negative transients of short duration can appear on the  $V_{\text{CC}}$  power supply. The AAT3526/7/8 series devices provide some immunity to line transients which can generate invalid reset pulses. Figure 1 shows typical behavior to short duration pulses versus RESET comparator overdrive. As shown in the Maximum Transient Duration vs. Reset Threshold Overdrive graph, when the transient voltage becomes larger, the time allowed before asserting a reset becomes shorter (e.g., typically a transient of 100mV below the reset threshold would have to present for more than 50 $\mu\text{s}$  to cause a reset). Immunity can be increased by the addition of a small bypass capacitor of 0.1 $\mu\text{F}$  connected as close to the  $V_{\text{CC}}$  pin as possible.

**Figure 2: Using Recommended Bypass Capacitor.**

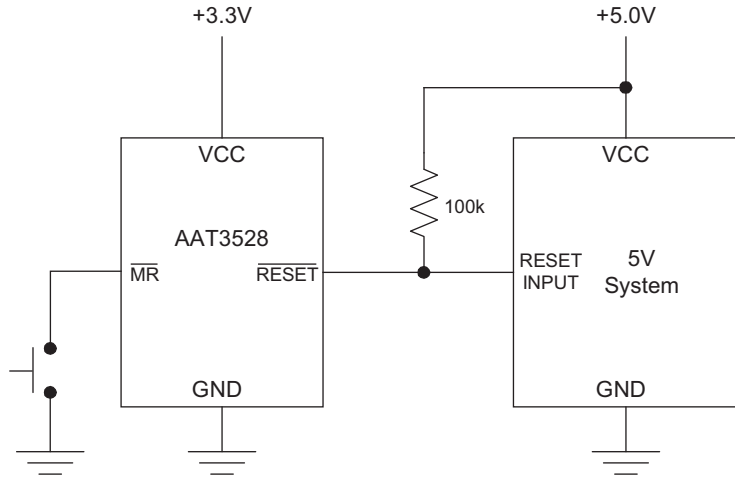

**Figure 3: Using AAT3528 Open Drain Output with Multiple Supplies.**



**Ordering Information and Factory-Trimmed Reset Thresholds<sup>1</sup>**

| Part Number <sup>2</sup>      | Marking <sup>3</sup> | Reset Threshold Voltage, $V_{TH}$ (V) |       |       |   |       |
|-------------------------------|----------------------|---------------------------------------|-------|-------|---|-------|
|                               |                      | $T_A = 25^\circ\text{C}$              |       |       | $T_A = -40^\circ\text{C to } +85^\circ\text{C}$ |       |
|                               |                      | Min                                   | Typ   | Max   | Min   | Max   |
| <b>AAT3526ICX-2.32-200-T1</b> | <b>NOXY</b>          | 2.285                                 | 2.320 | 2.355 | 2.262   | 2.378 |
| AAT3527ICX-2.32-200-T1        |                      |                                       |       |       |   |       |
| AAT3528ICX-2.32-200-T1        |                      |                                       |       |       |   |       |
| <b>AAT3526ICX-2.63-200-T1</b> | <b>DNXY</b>          | 2.591                                 | 2.630 | 2.669 | 2.564   | 2.696 |
| AAT3527ICX-2.63-200-T1        |                      |                                       |       |       |   |       |
| AAT3528ICX-2.63-200-T1        |                      |                                       |       |       |   |       |
| <b>AAT3526ICX-2.93-200-T1</b> | <b>DOXY</b>          | 2.886                                 | 2.930 | 2.974 | 2.857   | 3.003 |
| AAT3527ICX-2.93-200-T1        |                      |                                       |       |       |   |       |
| AAT3528ICX-2.93-200-T1        |                      |                                       |       |       |   |       |
| <b>AAT3526ICX-3.00-200-T1</b> | <b>FIXY</b>          | 2.955                                 | 3.000 | 3.045 | 2.925   | 3.075 |
| AAT3527ICX-3.00-200-T1        |                      |                                       |       |       |   |       |
| AAT3528ICX-3.00-200-T1        |                      |                                       |       |       |   |       |
| <b>AAT3526ICX-3.08-200-T1</b> | <b>EQXY</b>          | 3.034                                 | 3.080 | 3.126 | 3.003   | 3.157 |
| AAT3527ICX-3.08-200-T1        |                      |                                       |       |       |   |       |
| AAT3528ICX-3.08-200-T1        |                      |                                       |       |       |   |       |
| <b>AAT3526ICX-4.38-200-T1</b> | <b>GCXY</b>          | 4.314                                 | 4.380 | 4.446 | 4.271   | 4.490 |
| AAT3527ICX-4.38-200-T1        |                      |                                       |       |       |   |       |
| AAT3528ICX-4.38-200-T1        |                      |                                       |       |       |   |       |
| <b>AAT3526ICX-4.63-200-T1</b> | <b>DPXY</b>          | 4.561                                 | 4.630 | 4.699 | 4.514   | 4.746 |
| AAT3527ICX-4.63-200-T1        |                      |                                       |       |       |   |       |
| AAT3528ICX-4.63-200-T1        |                      |                                       |       |       |   |       |



All AnalogicTech products are offered in Pb-free packaging. The term “Pb-free” means semiconductor products that are in compliance with current RoHS standards, including the requirement that lead not exceed 0.1% by weight in homogeneous materials. For more information, please visit our website at <http://www.analogictech.com/about/quality.aspx>.

1. Contact local Sales Office for custom trimmed options.

2. Sample stock is generally held on all part numbers listed in **BOLD**.

3. XYY = assembly and date code.

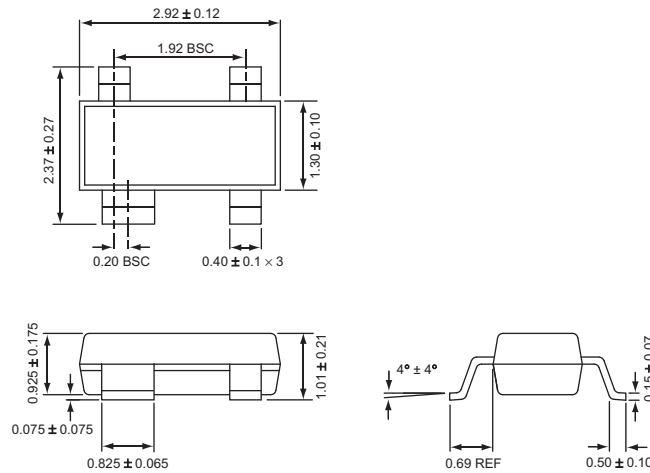
**Package Information**
**SOT143**

All dimensions in millimeters.

**Advanced Analogic Technologies, Inc.**  
 3230 Scott Boulevard, Santa Clara, CA 95054  
 Phone (408) 737-4600  
 Fax (408) 737-4611