



深圳市秋田视佳实业有限公司  
SHENZHEN AV-DISPLAY CO.,LTD.

深圳秋田视佳实业有限公司  
地址：深圳市华侨城东部工业区文昌街东北 C-7 栋  
电话:(086)0755-26919178 传真:(086)0755-26911092  
网址：[Http://www.av-display.com.cn](http://www.av-display.com.cn)

SHENZHEN AV-DISPLAY CO.,LTD  
Address: North East C-7 Building, Wenchang Street  
Eastern District, OCT, ShenZhen, China  
TEL: (086)0755-26919178 FAX: (086)0755-26911092  
[Http://www.av-display.com.cn](http://www.av-display.com.cn)

**SPECIFICATION  
FOR  
LCM MODULE**

**MODULE NO.: ABG122032F05-GHA-R  
DOC.REVISION: 00**

**Customer Approval:**

--

	SIGNATURE	DATE
PREPARED BY (RD ENGINEER)		Mar-08-2007
PREPARED BY (QA ENGINEER)		
CHECKED BY		
APPROVED BY		



深圳市秋田视佳实业有限公司  
SHENZHEN AV-DISPLAY CO.,LTD.

**DOCUMENT REVISION HISTORY**

<b>Version</b>	<b>DATE</b>	<b>DESCRIPTION</b>	<b>CHANGED BY</b>
00	Mar-08-2007	First issue	



深圳市秋田视佳实业有限公司  
SHENZHEN AV-DISPLAY CO.,LTD.

## **CONTENTS**

<b>1. Functions &amp; Features</b>	<b>1</b>
<b>2. Mechanical specifications</b>	<b>1</b>
<b>3. Block diagram</b>	<b>1</b>
<b>4. Dimensional Outline</b>	<b>2</b>
<b>5. Pin description</b>	<b>3</b>
<b>6. Maximum absolute limit</b>	<b>3</b>
<b>7. Electrical characteristics</b>	<b>3</b>
<b>8. Backlight Characteristics</b>	<b>4</b>
<b>9. Electro-Optical characteristics</b>	<b>4</b>
<b>10. Timing Characteristics</b>	<b>5</b>
<b>11. Control and display command</b>	<b>6</b>
<b>12. Quality Specifications</b>	<b>7~14</b>



## 1. FUNCTIONS & FEATURES

1.1. Format	: 122x32dots
1.2. LCD mode	: STN / Positive transfective mode / Grey
1.3. Viewing direction	: 6 o'clock
1.4. Driving scheme	: 1/32 Duty cycle, 1/5 Bias
1.5. Power supply voltage(V <sub>DD</sub> )	: 5.0V
1.6. LCD driving voltage	: 4.5V
1.7. Operation temp	: -20~70
1.8. Storage temp	: -30~80
1.9. Backlight color	: Amber
1.10.ROHS Standard	

## 2. MECHANICAL SPECIFICATIONS

2.1. Module size	: 65.4mm(L)*29.1mm(W)* 5.7MAX mm(H)
2.2. Viewing area	: 54.8mm(L)*19.1mm(W)
2.3. Dot pitch	: 0.40mm(L)*0.45mm(W)
2.4. Dot size	: 0.36mm(L)*0.41mm(W)
2.5. Weight	: Approx.

## 3. BLOCK DIAGRAM

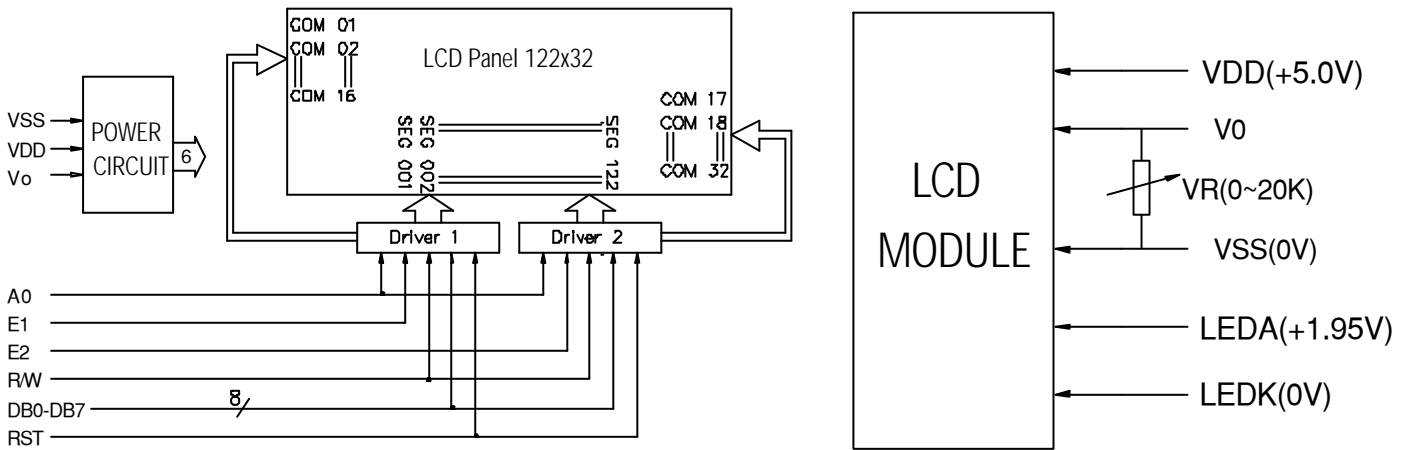

Figure 1. Block diagram



### 4. DIMENSIONAL OUTLINE

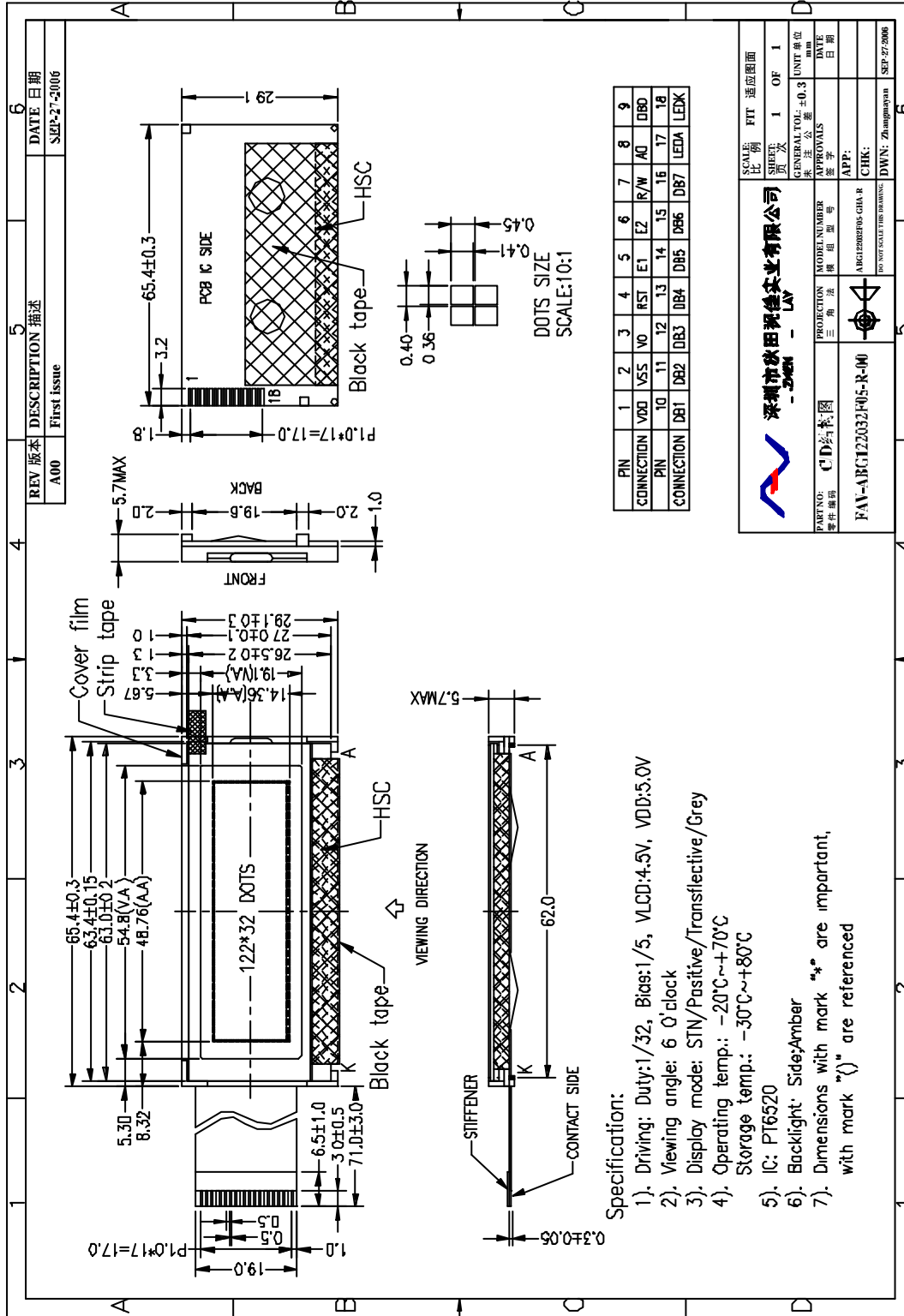

Figure 2. Dimensional outline



## 5. PIN DESCRIPTION

	Symbol	Function
1	VDD	Power supply(+5.0V)
2	VSS	GND(0V)
3	V0	Supply voltage for LCD drive
4	RST	Reset signal(The rise of the signal is for active and keep RST='h')
5	E1	Enable signal for IC1(left half of the panel)
6	E2	Enable signal for IC2(right half of the panel)
7	R/W	Read /write selection. (H: Read L: write)
8	A0	Register selection. (H: Data register L: Instruction register)
9~16	DB0~DB7	Data bus lines
17	LEDA	Power supply for backlight(+1.95V)
18	LEDK	Power supply for backlight(0V)

## 6. MAXIMUM ABSOLUTE LIMIT

Item	Symbol	MIN	MAX	Unit
Supply Voltage for Logic	V <sub>DD</sub>	-0.3	8.0	V
Supply Voltage for LCD	V <sub>0</sub>	-0.3	16.5	V
Input Voltage	V <sub>in</sub>	-0.3	V <sub>DD</sub> +0.3	V
Supply Current for Backlight	I <sub>F</sub> (Ta = 25°C)	---	100+100*20%	mA
Reverse Voltage for Backlight	V <sub>R</sub> (Ta = 25°C)	---	4	V
Operating Temperature	Top	-20	70	
Storage Temperature	Tst	-30	80	

## 7. ELECTRICAL CHARACTERISTICS

Item	Symbol	Condition	Min	Typ	Max	Unit
Supply Voltage for Logic	V <sub>DD</sub> -V <sub>SS</sub>	Ta = 25°C	4.5	5.0	5.5	V
Input High Voltage	V <sub>IH</sub>	Ta = 25°C	V <sub>DD</sub> -3.0	---	V <sub>DD</sub>	V
Input Low Voltage	V <sub>IL</sub>	Ta = 25°C	V <sub>SS</sub>	---	V <sub>SS</sub> +0.8	V
Output High Voltage	V <sub>OH</sub>	Ta = 25°C	2.4	---	---	V
Output Low Voltage	V <sub>OL</sub>	Ta = 25°C	---	---	0.4	V
Supply Current	I <sub>DD</sub>	Ta = 25°C	---	3	5	mA



## 8. BACKLIGHT CHARACTERISTICS

Ta = 25°C

Item	Symbol	Condition	Min	Typ	Max	Unit
Forward Voltage	VF	IF=100mA	1.8	1.95	2.1	V
Reverse Current	IR	Vr=4V	---	---	0.1	mA
Luminous Intensity	IV	---	---	---	---	Cd/m <sup>2</sup>
Wave length(Without LCD)	??		583	589	595	nm
Color			Amber			

## 9. ELECTRO-OPTICAL CHARACTERISTICS?

( VDD=5.0V, Ta = 25°C )

Item	Symbol	Condition	Min	Typ	Max	Unit
Operating Voltage	Vop	Ta = -20C	4.7	5.0	5.3	V
		Ta = 25°C	4.2	4.5	4.8	
		Ta = 70C	3.7	4.0	4.3	
Response time	Tr	Ta = 25°C	---	185	---	ms
	Tf		---	200	---	ms
Contrast	Cr	Ta = 25°C	---	4	---	---
Viewing angle range	θ	Cr=2	-40	---	+40	deg
	?		-40	---	+40	deg

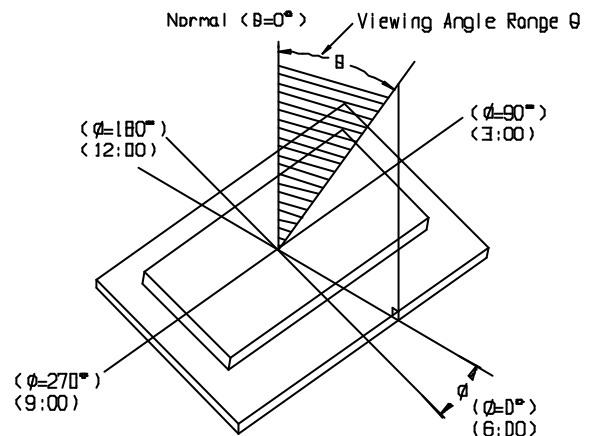
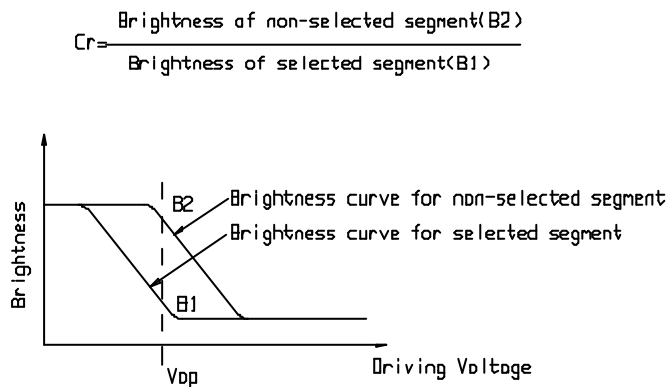



深圳市秋田视佳实业有限公司  
SHENZHEN AV-DISPLAY CO.,LTD.

## **10. TIMING CHARACTERISTICS**

(Please refer PTC PT6520 DATASHEETS )





Parameter	Symbol	Signal	Condition	Min	Typ	Max	Unit
System cycle time	$t_{CYC6}^{*1}$	A0, $\overline{CS}$	CL = 100 pF	1000	—	—	ns
Address setup time	$t_{AW6}$	R/ $\overline{W}$		20	—	—	ns
Address hold time	$t_{AH6}$			10	—	—	ns
Data setup time	$t_{DS6}$			D0 – D7	80	—	—
Data hold time	$t_{DH6}$	10			—	—	ns
Output disable time	$t_{OH6}$	10			—	60	ns
Access time	$t_{ACC6}$	—			—	90	ns
Enable pulse width: Read	$t_{EW}$	E	100	—	—	ns	
Enable pulse width: Write			80	—	—	ns	

\*1  $t_{cyc}$  indicates the cycle time during which  $\overline{CS} \cdot E = "H"$ . It does not mean the cycle time of signal E.

\*2 Each of the values where  $V_{ss} = -3.0V$  is about 200% of that where  $V_{ss} = -5.0V$  (i.e., the listed value).

\*3 The rise or fall time of input signals should be less than 15 ns.

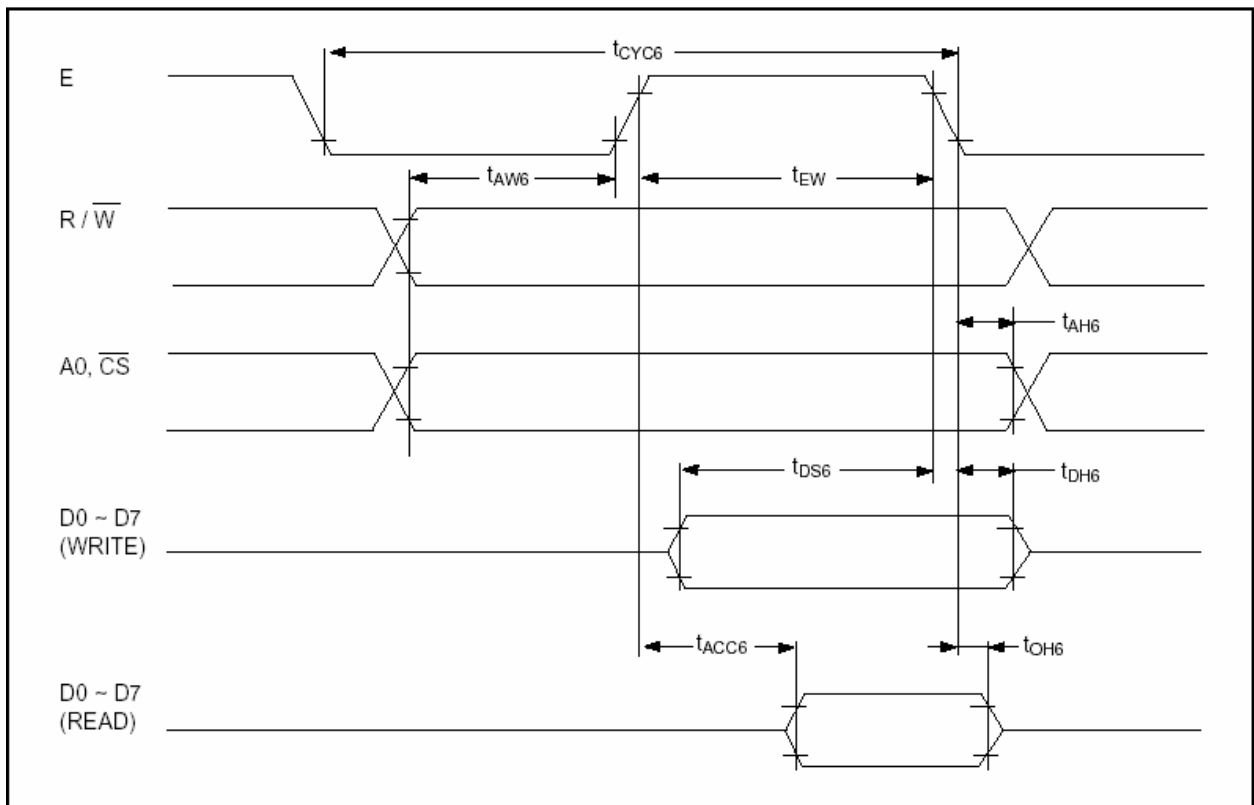

System bus read/write II (68-family MPU)

## 11. CONTROL AND DISPLAY INSTRUCTION



# 深圳市秋田视佳实业有限公司

## SHENZHEN AV-DISPLAY CO.,LTD.

	Command	Code											Function
		A0	RD	WR	D7	D6	D5	D4	D3	D2	D1	D0	
(1)	Display ON/OFF	0	1	0	1	0	1	0	1	1	1	0/1	Turns all display on or off, independently of display RAM data or internal status. 1: ON 0: OFF (Power-saving mode with static drive on)*
(2)	Display Start Line	0	1	0	1	1	0	Display Start Address (0 – 31)				0	Specifies RAM line corresponding to uppermost line (COM0) of display.
(3)	Set Page Address	0	1	0	1	0	1	1	1	0	Page (0–3)		Sets display RAM page in page address register.
(4)	Set Column (Segment) Address	0	1	0	0	Column Address (0–79)						0	Sets display RAM column address in column address register.
(5)	Read Status	0	0	1	Busy	ADC	ON/OFF	RESET	0	0	0	0	Reads the following status: BUSY 1: Internal operation 0: Ready ADC 1: CW output (forward) 0: CCW output (reverse) ON/OFF 1: Display off 0: Display on RESET 1: Being reset 0: Normal
(6)	Write Display Data	1	1	0					Write Data				
(7)	Read Display Data	1	0	1	Read Data						0	Reads data from display RAM onto data bus.	
(8)	Select ADC	0	1	0	1	0	1	0	0	0	0	0/1	Used to invert relationship of assignment between display RAM column addresses and segment driver outputs. 0: CW output (forward) 1: CCW output (reverse)
(9)	Static Drive ON/OFF	0	1	0	1	0	1	0	0	1	0	0/1	Selects normal display or static driving operation. 1: Static drive (power-saving mode) 0: Normal driving
(10)	Select Duty	0	1	0	1	0	1	0	1	0	0	0/1	Selects LCD cell driving duty 1: 1/32 0: 1/16
(11)	Read Modify Write	0	1	0	1	1	1	0	0	0	0	0	Increments column address counter by 1 when display data is written. (This is not done when data is read.)
(12)	End	0	1	0	1	1	1	0	1	1	1	0	Clears read modify write mode.
(13)	Reset	0	1	0	1	1	1	0	0	0	1	0	Sets display start line register on the first line. Also sets column address counter and page address counter to 0.

\* With display off (command (1)), static drive going on (9) invokes power-saving mode.



## 12.QUALITY SPECIFICATIONS

### 12.1 Standard of the product appearance test

Manner of appearance test: The inspection should be performed in using 20W x 2 fluorescent lamps. Distance between LCM and fluorescent lamps should be 100 cm or more. Distance between LCM and inspector eyes should be 30 cm or more.

Viewing direction for inspection is 45° from vertical against LCM.

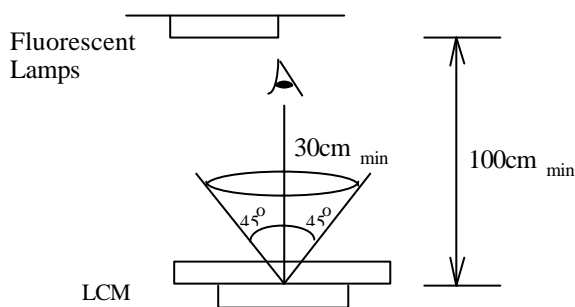

Definition of zone:

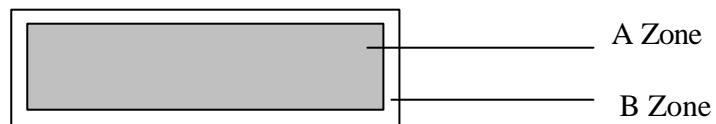

A Zone: Active display area (minimum viewing area).

B Zone: Non-active display area (outside viewing area).

### 12.2 Specification of quality assurance

AQL inspection standard

Sampling method: MIL-STD-105E, Level II, single sampling



深圳市秋田视佳实业有限公司  
SHENZHEN AV-DISPLAY CO.,LTD.

Defect classification (Note: \* is not including)

Classify	Item	Note	AQL	
Major	Display state	Short or open circuit	1	0.65
		LC leakage		
		Flickering		
		No display		
		Wrong viewing direction		
		Contrast defect (dim, ghost)	2	
		Back-light	1,8	
	Non-display	Flat cable or pin reverse	10	
Wrong or missing component		11		
Minor	Display state	Background color deviation	2	1.0
		Black spot and dust	3	
		Line defect, Scratch	4	
		Rainbow	5	
		Chip	6	
		Pin hole	7	
			Protruded	
	Polarizer	Bubble and foreign material	3	
	Soldering	Poor connection	9	
	Wire	Poor connection	10	
	TAB	Position, Bonding strength	13	

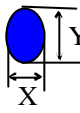
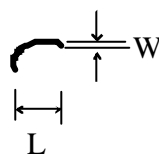

**Note on defect classification**

No.	Item	Criterion																				
1	Short or open circuit	Not allow																				
	LC leakage																					
	Flickering																					
	No display																					
	Wrong viewing direction																					
	Wrong Back-light																					
2	Contrast defect	Refer to approval sample																				
	Background color deviation																					
3	Point defect, Black spot, dust (including Polarizer)  $\phi = (X+Y)/2$	 <table border="1" data-bbox="912 990 1332 1281"> <thead> <tr> <th>Point Size</th> <th>Acceptable Qty.</th> </tr> </thead> <tbody> <tr> <td><math>\phi \leq 0.10</math></td> <td>Disregard</td> </tr> <tr> <td><math>0.10 &lt; \phi \leq 0.20</math></td> <td>3</td> </tr> <tr> <td><math>0.20 &lt; \phi \leq 0.25</math></td> <td>2</td> </tr> <tr> <td><math>0.25 &lt; \phi \leq 0.30</math></td> <td>1</td> </tr> <tr> <td><math>\phi &gt; 0.30</math></td> <td>0</td> </tr> </tbody> </table> <p>Unit : mm</p>	Point Size	Acceptable Qty.	$\phi \leq 0.10$	Disregard	$0.10 < \phi \leq 0.20$	3	$0.20 < \phi \leq 0.25$	2	$0.25 < \phi \leq 0.30$	1	$\phi > 0.30$	0								
Point Size	Acceptable Qty.																					
$\phi \leq 0.10$	Disregard																					
$0.10 < \phi \leq 0.20$	3																					
$0.20 < \phi \leq 0.25$	2																					
$0.25 < \phi \leq 0.30$	1																					
$\phi > 0.30$	0																					
4	Line defect, Scratch	 <table border="1" data-bbox="842 1444 1375 1697"> <thead> <tr> <th colspan="2">Line</th> <th>Acceptable Qty.</th> </tr> <tr> <th>L</th> <th>W</th> <th></th> </tr> </thead> <tbody> <tr> <td>---</td> <td><math>0.015 &lt; W</math></td> <td>Disregard</td> </tr> <tr> <td>3.0 L</td> <td><math>0.03 &lt; W</math></td> <td rowspan="2">2</td> </tr> <tr> <td>2.0 L</td> <td><math>0.05 &lt; W</math></td> </tr> <tr> <td>1.0 L</td> <td><math>0.1 &gt; W</math></td> <td>1</td> </tr> <tr> <td>---</td> <td><math>0.05 &lt; W</math></td> <td>Applied as point defect</td> </tr> </tbody> </table> <p>Unit: mm</p>	Line		Acceptable Qty.	L	W		---	$0.015 < W$	Disregard	3.0 L	$0.03 < W$	2	2.0 L	$0.05 < W$	1.0 L	$0.1 > W$	1	---	$0.05 < W$	Applied as point defect
Line		Acceptable Qty.																				
L	W																					
---	$0.015 < W$	Disregard																				
3.0 L	$0.03 < W$	2																				
2.0 L	$0.05 < W$																					
1.0 L	$0.1 > W$	1																				
---	$0.05 < W$	Applied as point defect																				
5	Rainbow	Not more than two color changes across the viewing area.																				

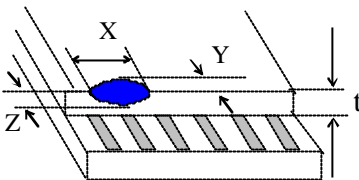
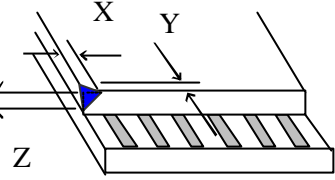
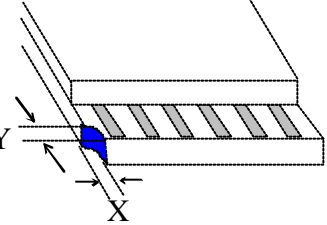
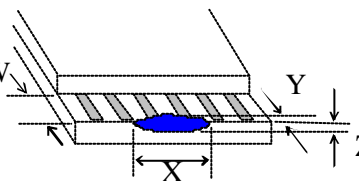
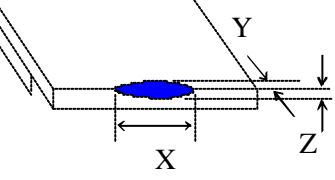

No	Item	Criterion																																
6	<p>Chip</p> <p>Remark:            X: Length direction            Y: Short direction            Z: Thickness direction            t: Glass thickness            W: Terminal Width</p>	 <p>Acceptable criterion</p> <table border="1" data-bbox="981 459 1356 537"> <thead> <tr> <th>X</th> <th>Y</th> <th>Z</th> </tr> </thead> <tbody> <tr> <td>2</td> <td>0.5mm</td> <td>t/2</td> </tr> </tbody> </table>  <p>Acceptable criterion</p> <table border="1" data-bbox="965 761 1356 840"> <thead> <tr> <th>X</th> <th>Y</th> <th>Z</th> </tr> </thead> <tbody> <tr> <td>2</td> <td>0.5mm</td> <td>t</td> </tr> </tbody> </table>  <p>Acceptable criterion</p> <table border="1" data-bbox="981 1041 1356 1153"> <thead> <tr> <th>X</th> <th>Y</th> <th>Z</th> </tr> </thead> <tbody> <tr> <td>3</td> <td>2</td> <td rowspan="2">t</td> </tr> <tr> <td colspan="2">shall not reach to ITO</td> </tr> </tbody> </table>  <p>Acceptable criterion</p> <table border="1" data-bbox="965 1411 1356 1489"> <thead> <tr> <th>X</th> <th>Y</th> <th>Z</th> </tr> </thead> <tbody> <tr> <td>Disregard</td> <td>0.2</td> <td>t</td> </tr> </tbody> </table>  <p>Acceptable criterion</p> <table border="1" data-bbox="965 1680 1324 1758"> <thead> <tr> <th>X</th> <th>Y</th> <th>Z</th> </tr> </thead> <tbody> <tr> <td>5</td> <td>2</td> <td>t/3</td> </tr> </tbody> </table>	X	Y	Z	2	0.5mm	t/2	X	Y	Z	2	0.5mm	t	X	Y	Z	3	2	t	shall not reach to ITO		X	Y	Z	Disregard	0.2	t	X	Y	Z	5	2	t/3
X	Y	Z																																
2	0.5mm	t/2																																
X	Y	Z																																
2	0.5mm	t																																
X	Y	Z																																
3	2	t																																
shall not reach to ITO																																		
X	Y	Z																																
Disregard	0.2	t																																
X	Y	Z																																
5	2	t/3																																

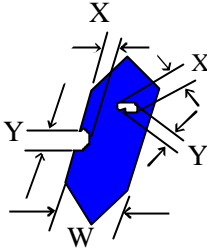
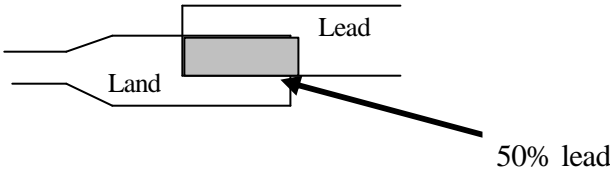

No.	Item	Criterion								
7	Segment pattern $W = \text{Segment width}$ $\phi = (X+Y)/2$	(1) Pin hole $\phi < 0.10\text{mm}$ is acceptable.  <table border="1" data-bbox="906 584 1350 754"> <thead> <tr> <th>Point Size</th> <th>Acceptable Qty</th> </tr> </thead> <tbody> <tr> <td><math>\phi &lt; 1/4W</math></td> <td>Disregard</td> </tr> <tr> <td><math>1/4W &lt; \phi &lt; 1/2W</math></td> <td>1</td> </tr> <tr> <td><math>\phi &gt; 1/2W</math></td> <td>0</td> </tr> </tbody> </table> <p style="text-align: center;">Unit: mm</p>	Point Size	Acceptable Qty	$\phi < 1/4W$	Disregard	$1/4W < \phi < 1/2W$	1	$\phi > 1/2W$	0
Point Size	Acceptable Qty									
$\phi < 1/4W$	Disregard									
$1/4W < \phi < 1/2W$	1									
$\phi > 1/2W$	0									
8	Back-light	(1) The color of backlight should correspond its specification. (2) Not allow flickering								
9	Soldering	(1) Not allow heavy dirty and solder ball on PCB. (The size of dirty refer to point and dust defect) (2) Over 50% of lead should be soldered on Land. 								
10	Wire	(1) Copper wire should not be rusted (2) Not allow crack on copper wire connection. (3) Not allow reversing the position of the flat cable. (4) Not allow exposed copper wire inside the flat cable.								
11*	PCB	(1) Not allow screw rust or damage. (2) Not allow missing or wrong putting of component.								

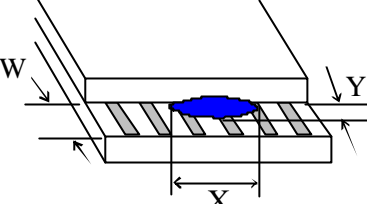
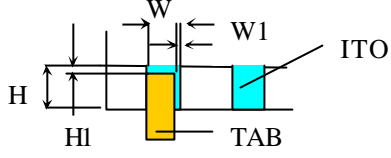
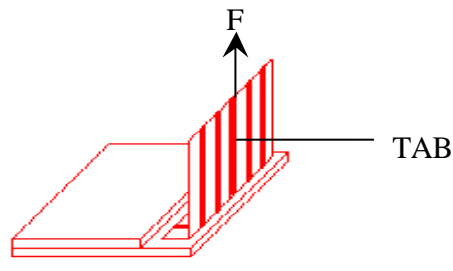

No	Item	Criterion				
12	Protruded  W: Terminal Width	 <p>Acceptable criteria: <math>Y \leq 0.4</math></p>				
13	TAB	<p>1. Position</p>  <table border="1" data-bbox="1161 772 1385 900"> <tr> <td>W1</td> <td>1/3W</td> </tr> <tr> <td>H1</td> <td>1/3H</td> </tr> </table> <p>2 TAB bonding strength test</p>  <p><math>P (=F/\text{TAB bonding width})</math> 650gf/cm ,(speed rate: 1mm/min) 5pcs per SOA (shipment)</p>	W1	1/3W	H1	1/3H
W1	1/3W					
H1	1/3H					
14	Total no. of acceptable Defect	<p>A. Zone</p> <p>Maximum 2 minor non-conformities per one unit. Defect distance: each point to be separated over 10mm</p> <p>B. Zone</p> <p>It is acceptable when it is no trouble for quality and assembly in customer's end product.</p>				





### 12.3 Reliability of LCM

Reliability test condition:

Item	Condition	Time (hrs)	Assessment
High temp. Storage	80°C	48	No abnormalities in functions and appearance
High temp. Operating	70°C	48	
Low temp. Storage	-30°C	48	
Low temp. Operating	-20°C	48	
Humidity	40°C/ 90%RH	48	
Temp. Cycle	0°C ← 25°C → 50°C (30 min ← 5 min → 30min)	10cycles	

Recovery time should be 24 hours minimum. Moreover, functions, performance and appearance shall be free from remarkable deterioration within 50,000 hours under ordinary operating and storage conditions room temperature ( $20 \pm 8^\circ\text{C}$ ), normal humidity (below 65% RH), and in the area not exposed to direct sun light.

### 12.4 Precaution for using LCD/LCM

LCD/LCM is assembled and adjusted with a high degree of precision. Do not attempt to make any alteration or modification. The followings should be noted.

#### General Precautions:

1. LCD panel is made of glass. Avoid excessive mechanical shock or applying strong pressure onto the surface of display area.
2. The polarizer used on the display surface is easily scratched and damaged. Extreme care should be taken when handling. To clean dust or dirt off the display surface, wipe gently with cotton, or other soft material soaked with isopropyl alcohol, ethyl alcohol or trichlorotrifluoroethane, do not use water, ketone or aromatics and never scrub hard.
3. Do not tamper in any way with the tabs on the metal frame.
4. Do not make any modification on the PCB without consulting AV.
5. When mounting a LCM, make sure that the PCB is not under any stress such as bending or twisting. Elastomer contacts are very delicate and missing pixels could result from slight dislocation of any of the elements.
6. Avoid pressing on the metal bezel, otherwise the elastomer connector could be deformed and lose contact, resulting in missing pixels and also cause rainbow on the display.
7. Be careful not to touch or swallow liquid crystal that might leak from a damaged cell. Any liquid crystal adheres to skin or clothes, wash it off immediately with soap and water.



### Static Electricity Precautions:

1. CMOS-LSI is used for the module circuit; therefore operators should be grounded when ever he/she comes into contact with the module.
2. Do not touch any of the conductive parts such as the LSI pads; the copper leads on the PCB and the interface terminals with any parts of the human body.
3. Do not touch the connection terminals of the display with bare hand; it will cause disconnection or defective insulation of terminals.
4. The modules should be kept in anti-static bags or other containers resistant to static for storage.
5. Only properly grounded soldering irons should be used.
6. If an electric screwdriver is used, it should be grounded and shielded to prevent sparks.
7. The normal static prevention measures should be observed for work clothes and working benches.
8. Since dry air is inductive to static, a relative humidity of 50-60% is recommended.

### Soldering Precautions:

1. Soldering should be performed only on the I/O terminals.
2. Use soldering irons with proper grounding and no leakage.
3. Soldering temperature:  $280^{\circ}\text{C}\pm 10^{\circ}\text{C}$
4. Soldering time: 3 to 4 second.
5. Use eutectic solder with resin flux filling.
6. If flux is used, the LCD surface should be protected to avoid spattering flux.
7. Flux residue should be removed.

### Operation Precautions:

1. The viewing angle can be adjusted by varying the LCD driving voltage  $V_o$ .
2. Since applied DC voltage causes electro-chemical reactions, which deteriorate the display, the applied pulse waveform should be a symmetric waveform such that no DC component remains. Be sure to use the specified operating voltage.
3. Driving voltage should be kept within specified range; excess voltage will shorten display life.
4. Response time increases with decrease in temperature.
5. Display color may be affected at temperatures above its operational range.
6. Keep the temperature within the specified range usage and storage. Excessive temperature and humidity could cause polarization degradation, polarizer peel-off or generate bubbles.
7. For long-term storage over  $40^{\circ}\text{C}$  is required, the relative humidity should be kept below 60%, and avoid direct sunlight.

### Limited Warranty

AV LCDs and modules are not consumer products, but may be incorporated by AV's customers into consumer products or components thereof, AV does not warrant that its LCDs and components are fit for any such particular purpose.

1. The liability of AV is limited to repair or replacement on the terms set forth below. AV will not be responsible for any subsequent or consequential events or injury or damage to any personnel or user including third party personnel and/or user. Unless otherwise agreed in writing between AV and the customer, AV will only replace or repair any of its LCD which is found defective electrically or visually when inspected in accordance with AV general LCD inspection standard . (Copies available on request)
2. No warranty can be granted if any of the precautions state in handling liquid crystal display above has been disregarded. Broken glass, scratches on polarizer mechanical damages as well as defects that are caused accelerated environment tests are excluded from warranty.
3. In returning the LCD/LCM, they must be properly packaged; there should be detailed description of the ailures or defect