

Feature

- Glass Passivated Chip Junction
- Reverse Voltage - 100 to 1000 V
- Forward Current - 2 A
- High Surge Current Capability
- Designed for Surface Mount Application

Maximum Ratings and Electrical characteristics

Single-phase, half-wave, 60 Hz, resistive or inductive load .

For capacitive load, derate current by 20%.

Parameter	Symbol	ABS 201	ABS 202	ABS 204	ABS 206	ABS 208	ABS 210	Units
Maximum Repetitive Peak Reverse Voltage Maximum DC Blocking Voltage	V_{RRM} V_{DC}	100	200	400	600	800	1000	V
Maximum RMS voltage	$V_{R(RMS)}$	70	140	280	420	560	700	V
Averager Rectified Output Current at $T_a=40^{\circ}C$	I_o	2.0						A
Peak Forward Surge Current 8.3 ms Single Half Sine Wave Superimposed on Rated Load (JEDEC Method)	I_{FSM}	50						A
Maximum DC Reverse Current @ $T=2.0A$ at Rated DC Blocking Voltage @ $T=125A$	V_F	1.0						V
Peak Reverse Current at Rated DC Blocking Voltage $T_A=25^{\circ}C$ $T_A=125^{\circ}C$	I_R	5.0 500						μA
Typical Junction Capacitance (Note1)	C_j	25						pF
Typical Thermal Resistance (Note2)	$R_{\theta JA}$	80						$^{\circ}C/W$
Operating and Storage Temperature Range	T_J, T_{STG}	-55 to +150						$^{\circ}C$

Note:

1. Measured at 1MHz and applied reverse voltage of 4 V D.C.
2. Mounted on glass epoxy PC board with $4 \times 2.54mm^2$ copper pad.

Typical Characteristics

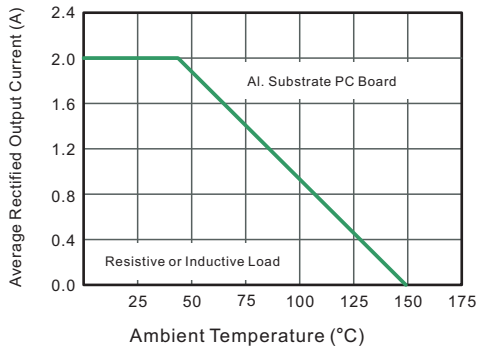

Fig.1 Average Rectified Output Current Derating Curve

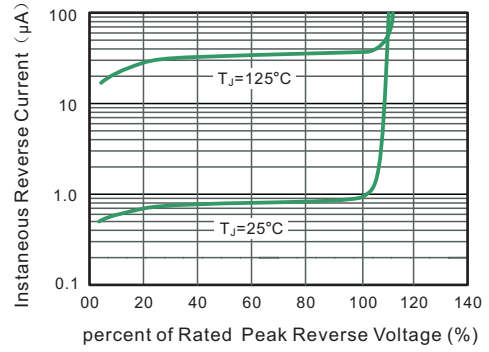

Fig.2 Typical Reverse Characteristics

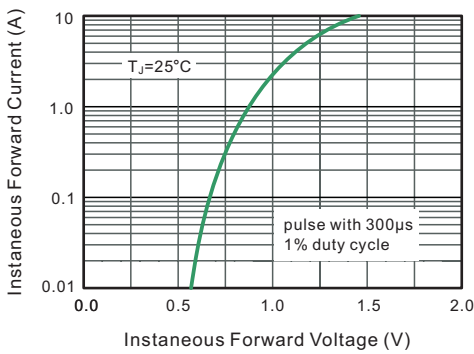

Fig.3 Typical Instantaneous Forward Characteristics

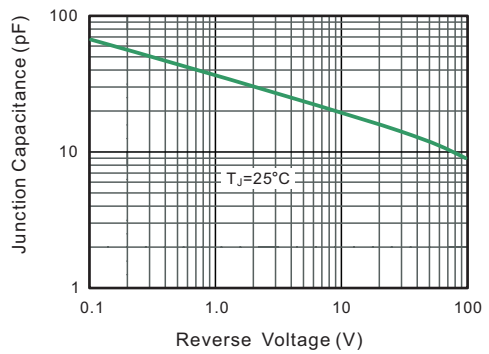

Fig.4 Typical Junction Capacitance

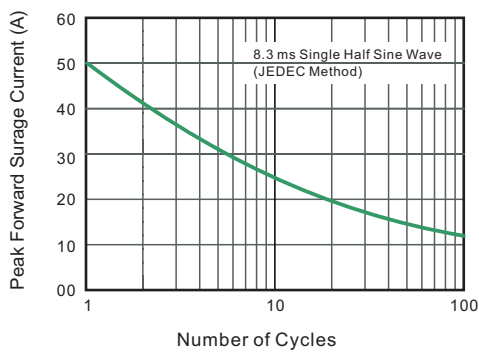
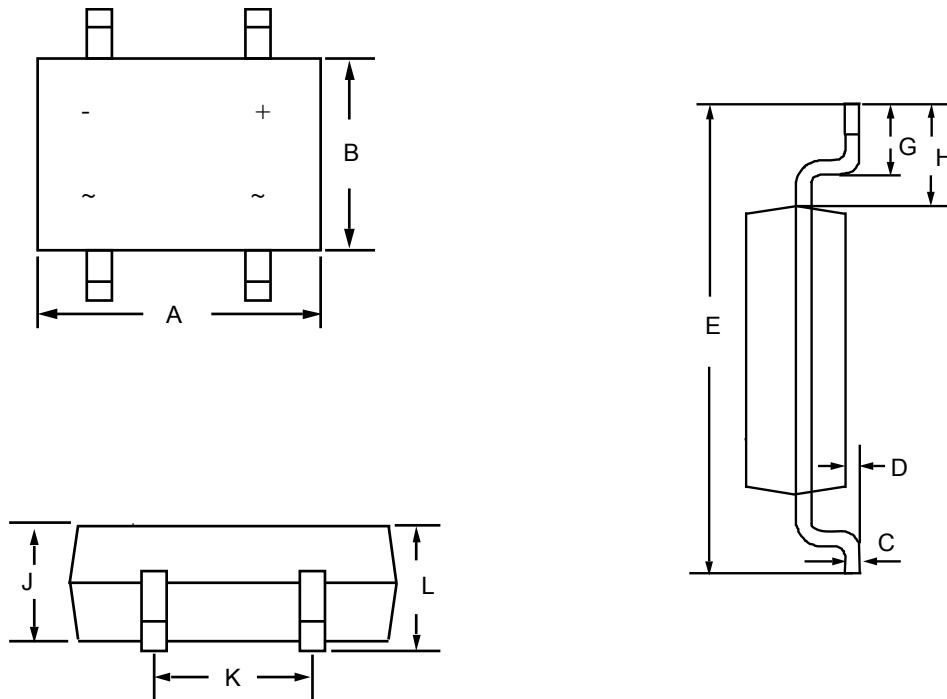



Fig.5 Maximum Non-Repetitive Peak Forward Surge Current

Product dimension (ABS)



Dimension	Millimeters	
	MIN	MAX
A	4.90	5.30
B	4.30	4.80
C	0.15	0.25
D	0.05	0.15
E	6.00	6.40
G	0.30	0.80
H	0.80	1.20
J	1.20	1.40
K	3.80	4.20
L	--	1.50

IMPORTANT NOTICE

 and **Prisemi**[®] are registered trademarks of **Prisemi Electronics Co., Ltd (Prisemi)** ,Prisemi reserves the right to make changes without further notice to any products herein. Prisemi makes no warranty, representation or guarantee regarding the suitability of its products for any particular purpose, nor does Prisemi assume any liability arising out of the application or use of any product or circuit, and specifically disclaims any and all liability, including without limitation special, consequential or incidental damages. “Typical” parameters which may be provided in Prisemi data sheets and/or specifications can and do vary in different applications and actual performance may vary over time. All operating parameters, including “Typicals” must be validated for each customer application by customer’s technical experts. Prisemi does not convey any license under its patent rights nor the rights of others. The products listed in this document are designed to be used with ordinary electronic equipment or devices, Should you intend to use these products with equipment or devices which require an extremely high level of reliability and the malfunction of with would directly endanger human life (such as medical instruments, aerospace machinery, nuclear-reactor controllers, fuel controllers and other safety devices), please be sure to consult with our sales representative in advance.

Website: <http://www.prisemi.com>

For additional information, please contact your local Sales Representative.

©Copyright 2009, Prisemi Electronics

 **Prisemi**[®] is a registered trademark of Prisemi Electronics.

All rights are reserved.