

**GLASS PASSIVATED
SURFACE MOUNT BRIDGE RECTIFIER**

**REVERSE VOLTAGE – 1000 Volts
FORWARD CURRENT – 2 Amperes**

FEATURES

- Ideal for printed circuit board
- Reliable low cost construction utilizing molded plastic technique

MECHANICAL DATA

- Case Material: “Green” molding compound, UL flammability classification 94V-0,(No Br. Sb. Cl.) “Halogen-free”
- UL recognized file # E364304
- Polarity indicator: As marked on the body
- Weight: 98 mg (Approximate)
- Marking Code: ABS20M

ABS

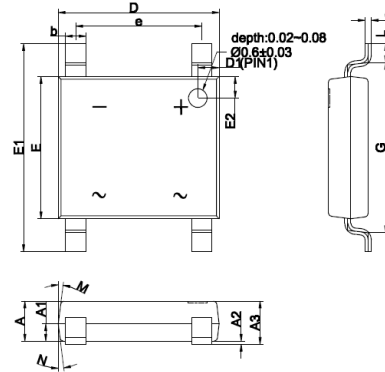

ABS		
DIM	MIN	MAX
A	1.20	1.30
A1	0.43	0.63
A2	0.00	0.10
A3	1.20	1.40
b	0.50	0.80
C	0.10	0.30
D	4.85	5.25
D1	0.45	0.85
e	3.80	4.20
E	4.25	4.65
E1	6.40	6.80
E2	0.45	0.85
G	5.20	5.60
L	0.40	0.80
M	7° TYP.	
N	7° TYP.	
All dimension in millimeter		

MAXIMUM RATINGS AND ELECTRICAL CHARACTERISTICS

Ratings at 25°C ambient temperature unless otherwise specified.

ABSOLUTE RATINGS

PARAMETER	SYMBOL	VALUE	UNIT
Maximum repetitive peak reverse voltage	V_{RRM}	1000	V
Maximum DC blocking voltage	V_{DC}	1000	V
Average rectified output current per device	$I_{(AV)}$	2	A
Peak forward surge current 8.3ms single half sine-wave superimposed on rated load	I_{FSM}	55	A
	@ $T_A=25^\circ\text{C}$	44	
	@ $T_A=125^\circ\text{C}$ (Note 1)		
Peak forward surge current 1ms single half sine-wave superimposed on rated load	I_{FSM}	110	A
	@ $T_A=25^\circ\text{C}$	88	
	@ $T_A=125^\circ\text{C}$ (Note 1)		
$I^2 t$ rating for fusing ($t = 8.3\text{ms}$)	$I^2 t$	10.37	A^2S
Operating and storage temperature range	T_J, T_{STG}	-55 to +150	$^\circ\text{C}$

STATIC ELECTRICAL CHARACTERISTICS

PARAMETER	TEST CONDITION	SYMBOL	MAX.	UNIT
Forward voltage (Note1)	$I_F = 1\text{A}$ $T_A = 25^\circ\text{C}$	V_F	0.95	V
Leakage current	$V_R = 1000\text{V}$ $T_A = 25^\circ\text{C}$	I_R	10	μA
	$T_A = 125^\circ\text{C}$ (Note1)		100	
Typical junction capacitance (Note 2)		C_J	12.34	pF

THERMAL CHARACTERISTICS

PARAMETER	SYMBOL	TYP.	UNIT
Typical thermal resistance (Note 3)	R_{thJC}	12	$^\circ\text{C/W}$
	R_{thJL}	15.5	
	R_{thJA}	26	

Note :

- (1) Perform static test after the temperature of oven is steady 20 minutes.
- (2) Measured at 1.0MHz and applied reverse voltage of 4.0V DC
- (3) Thermal resistance junction to case, lead and ambient in accordance with JESD-51. Unit mounted on 1oz/ft² 30mm *30mm copper pad per pin.

REV.1, Sep.-2016, KBDA37

RATING AND CHARACTERISTIC CURVES ABS20M



FIG.1- FORWARD CURRENT DERATING CURVE

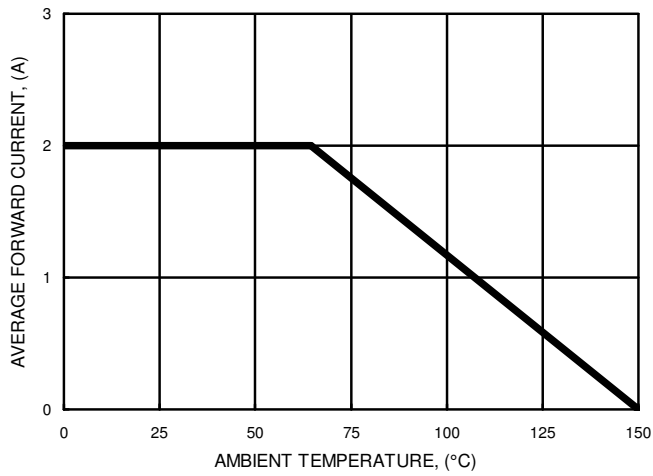

FIG.2- MAXIMUM NON-REPETITIVE SURGE CURRENT

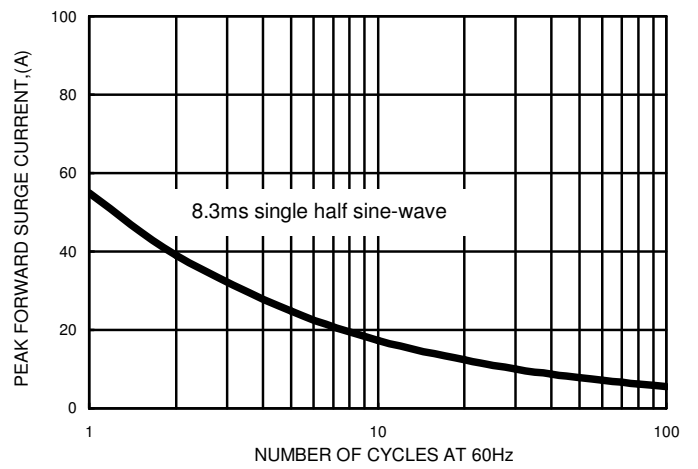

FIG.3- TYPICAL FORWARD CHARACTERISTICS

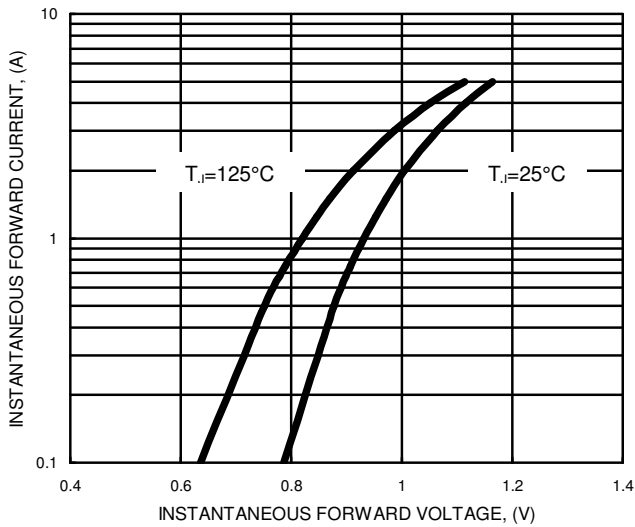

FIG.4- TYPICAL JUNCTION CAPACITANCE

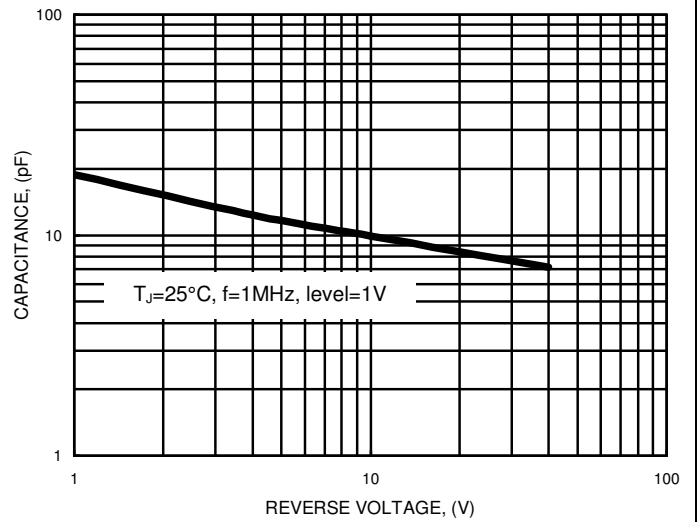
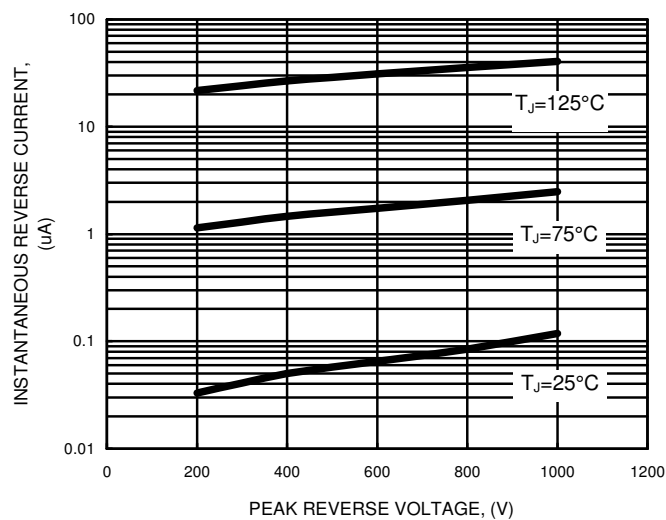

FIG.5- TYPICAL REVERSE CHARACTERISTICS



Important Notice and Disclaimer

LSC reserves the right to make changes to this document and its products and specifications at any time without notice. Customers should obtain and confirm the latest product information and specifications before final design, purchase or use.

LSC makes no warranty, representation or guarantee regarding the suitability of its products for any particular purpose, nor does LSC assume any liability for application assistance or customer product design. LSC does not warrant or accept any liability with products which are purchased or used for any unintended or unauthorized application.

No license is granted by implication or otherwise under any intellectual property rights of LSC. LSC products are not authorized for use as critical components in life support devices or systems without express written approval of LSC.