

GENERAL DESCRIPTION

AC0028S is high performance primary sensing regulator (PSR) and monolithic switch power controller which is designed for small-power supply equipment with current mode control. Built-in accurate CV/CC control circuit, eliminates optocoupler, TL431 and its related loop devices. High integration design, a high performance power BJT and PFM controller and all kinds of protection circuits in one chip, to minimize the peripheral components to save the cost greatly. AC0028S can be simply designed a typical flyback switch converter, the unique driving technology promotes the characteristics of withstand voltage and achieves excellent converting efficiency

FEATURES

- ◆ Built-in 700V power BJT;

- ◆ PSR control, eliminates optocoupler and TL431;
- ◆ Accurate CV/CC control
- ◆ Hysteresis over-temperature protection (OTP) circuit
- ◆ Higher efficiency and meet Level 6 efficiency standards
- ◆ Output voltage protection (OVP/UVP)
- ◆ < 100 mW no-load consumption
- ◆ Auto-Restart function
- ◆ Ultra-low start-up current
- ◆ Good EMC characteristic allows the simple EMC circuit

APPLICATIONS

- ◆ Intelligent mobile phone/small size tablet computer
- ◆ Digital cameras and other small digital products
- ◆ Power adapters for network products etc
- ◆ RCC solutions Replace

APPLICATION DIAGRAM

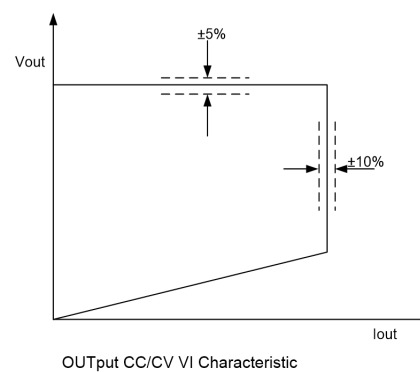
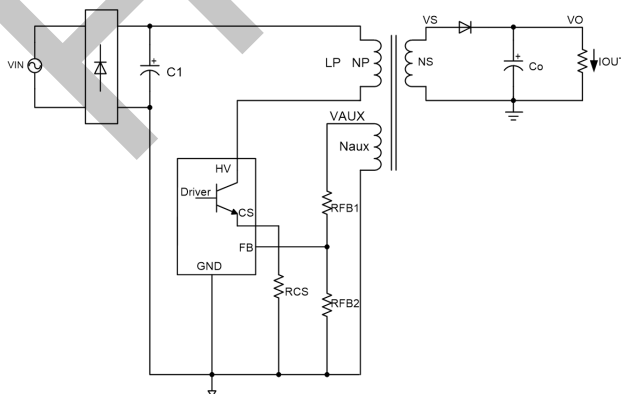

PIN DEFINITION

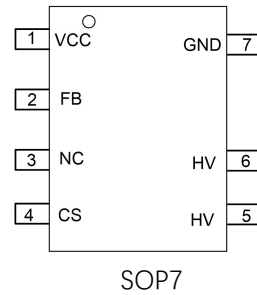

PIN Function Description

Pin #	Name	Function Description
1	VCC	Power Supply Pin of IC. An external filter capacitor of Low ESR electrolytic capacitor is suggested to gain stable supply voltage .
2	FB	Output Feedback Pin to detect output condition through the auxiliary winding voltage of the transformer
3	NC	Not Connected
4	CS	Connect external primary current sensing resistor (R_{cs}), IC can detect primary current via external sensing resistor. When voltage on the resistor surpasses maximum value, internal Power BJT will be turned off immediately
5-6	HV	The Collector of internal Power Transistor
7	GND	Ground Pin

FUNCTIONAL BLOCK DIAGRAM

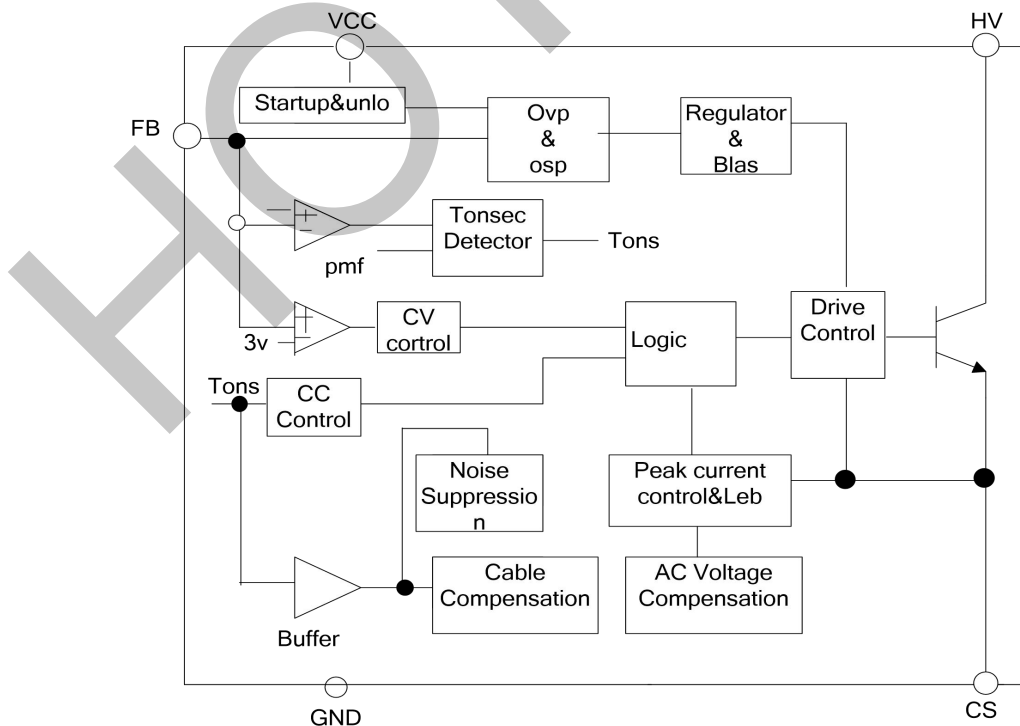

ABSOLUTE MAXIMUM RATINGS

Internal power BJT Vcbo	700V
BJT Ic Peak Current:	1.5A
VCC Pin Voltage	12 V
FB Pin Voltage	7V
Others Pin Voltage	7V
Operating Temperature (Tj)	0~+140°C
Storage Temperature	-55~+150°C
Lead Temperature	+260°C/10S

Notes:

- 1.All voltages referred to Ic GND (TA=25°C),
2. Duration not exceed 2 msec.
- 3.Instant maximum ratings specified will not cause permanent damage To the product, while long maximum ratings specified applied will do And may affect product reliability.

Application range

Type.	Vin:AC 90V~265V,50/60HZ
AC0028S	10W

ELECTRICAL CHARACTERISTICS (Unless otherwise specified, parameters are measured by setting GND Potential as zero Potential in room Temp.)

Parameter	Symbol	Conditions	Min	Type	Max	Unit
VCC UVLO						
Star-up Voltage	VCC-ON		7.5	8.0	8.8	V
Shut down	VCC-OFF		3.0	3.3	3.5	V
Star-up Current	IStar			0.8	3	uA
Operating Current	ICC	Static current		400	600	uA
Max. Operating Voltage	VCC-MAX				8.5v	
CURRENT SENSE SECTION						
Maximum Current to CS PIN	ICS		3.4	4	5	uA
Current Sense Threshold Voltage	VCS				510	mV
Leading Edge Blanking	TLEB	Ic=1mA		500		nS
FEED BACK INPUT SECTION						
FB Reference Voltage	VREF-FB		2.85	2.9	2.95	V
Input Resistance of FB Pin	RFB		1.2	1.5	2	MΩ
Feedback Threshold Voltage	VFB-MAX				5	V
POWER BJT SECTION						
Collector-emitter Saturation Voltage	VCEsat	Ic=500mA Ib=100mA			0.5	V
Collector-Base Voltage	VCBO		700			V
OVER TEMPERATURE PROTECTION(OTP)						
Shutdown Temperature	TSHDN		135	140	145	°C
Temperature Hysteresis	THYS		125	130	135	°C

FUNCTION DESCRIPTION

AC0028S is specially designed for the charger/adapter of small power digital products. To use PSR control technology to provide accurate (CV/CC) characteristics. The controller works in PFM mode and the switching frequency can be automatically adjusted as per the load. Optimized driving circuit greatly promotes withstand voltage of the power BJT and minimizes the switching loss, so as to make the circuit have excellent converting efficiency

CONSTANT VOLTAGE(CV) OPERATION

When the circuit is operates in CV area, FB will detect the output voltage when the power BJT turn-off through the sensing voltage by auxiliary winding of the transformer, to make the output voltage stablized in the fixed value. In the turn-on period of the output rectifier diode D, it's given the output winding voltage and auxiliary winding voltage as follows

$$V_{AUX} = \frac{N_{AUX}}{N_s} \cdot (V_o + V_d) \text{ -----(5)}$$

Vaux : auxiliary winding voltage; Nb: subsidiary winding turns; NS: output winding turns; Vd: forward voltage drop of output rectifier diode

FB will test the auxiliary winding voltage while the power BJT off-time to regulate the output voltage. In order to avoid the peak influence happens in power BJT turn-off resulting from the leakage inductance of the transformer, and considering the accuracy of sampling voltage, FB captures the auxiliary winding detection sampling points as below:

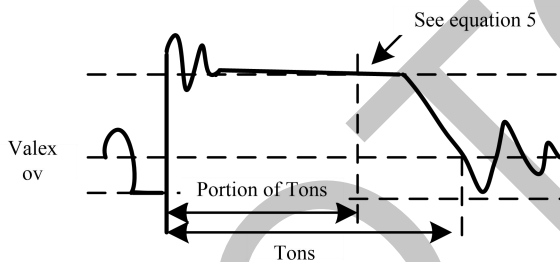

CONSTANT CURRENT(CC) OPETATION

AC0028S CC control circuit is requested the converter operating in DCM . In CC operation mode , the CC control circuit will fix the proportion between the Tons and Toffs produced by diode rectifier D. When Tons time, the primary energy of the transformer will be converted to the secondary winding, via the rectifier diode then charge the output capacitor and supply load simultaneously.

When Toffs, the primary coil stores the energy, the output filter capacitor makes load discharge. In CC operation area, AC0028S switch frequency will follow the output load direct ratio contro detected by FB Voltage

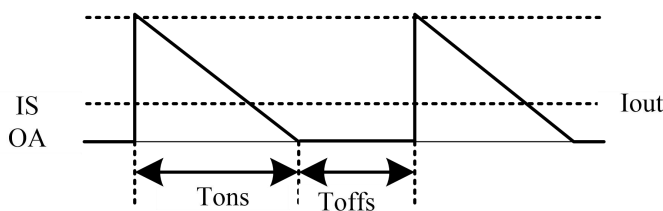

The secondary rectifier diode peak current is determined by the peak current of primary-side inductance which also affects the output current. The corresponding relation between the primary peak current and the secondary peak current is as follows

$$I_{pks} = \frac{N_p}{N_s} \cdot I_{pk}$$

I_{pk} : primary peak current ; N_p : primary winding turns; N_s : secondary winding turns;
 I_{pks} : secondary peak current

And primary inductance peak current is determined by Pin 4 to RCS resistance, the primary inductance peak current and RCS resistance are in inverse proportion, so only need to adjust CS resistance to achieve different output currents. Output current I_{out} and primary current are given by

$$I_{out} = \frac{1}{2} \cdot I_{pks} \cdot \frac{T_{ons}}{T_{ons} + T_{offs}}$$

I_{out} : Output current; T_{ons} : secondary rectifier diode on-time; T_{offs} : secondary rectifier diode off-time

OUTPUT CABLE COMPENSATION

AC0028S built-in output cable drop compensation circuit. When it outputs different loads, the cable drop compensation circuit provides cable drop voltage compensation which is in fixed proportion with output voltage.

PROTECTIVE FUNCTIONS

In order to guarantee a safe and reliable circuit to all occasions, AC0028S built-in rich protection circuits, such as OCP ,OVP, FB open-loop protection etc. as intergration. Once abnormality, it will come into protection mode

TYPICAL APPLICATION CIRCUIT

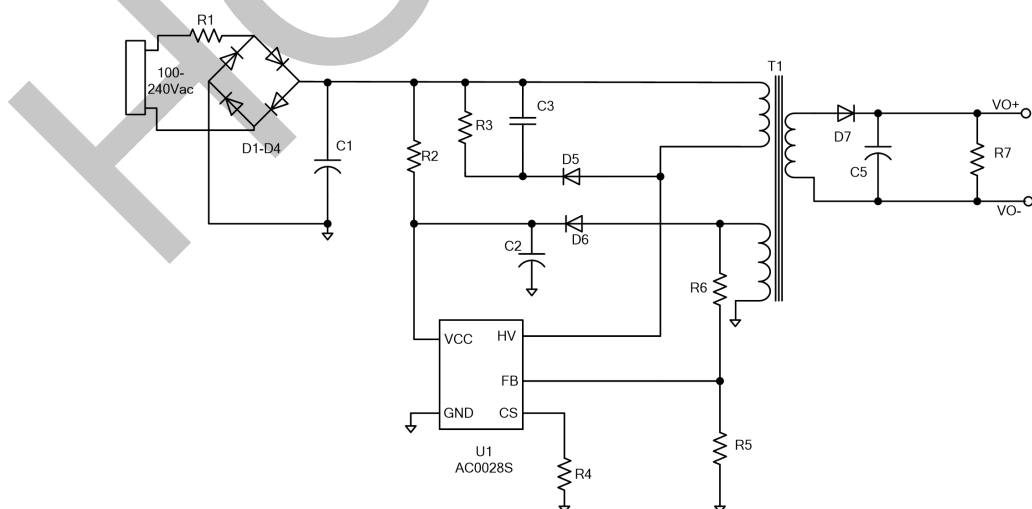

Typical application of AC0028S for RCC replace (Output: 5V/2.0A)

PACKAGING INFORMATION

SOP7 Package

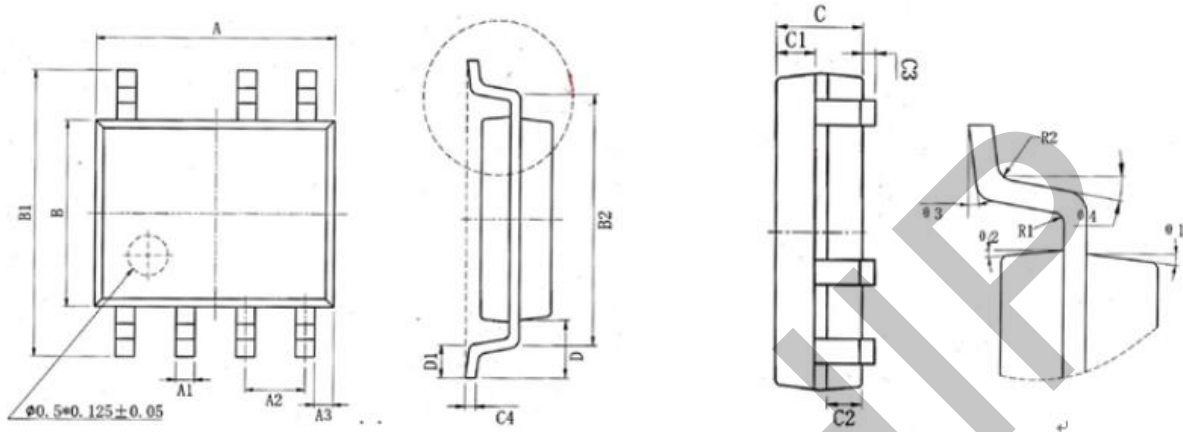

Item	Size	Min. (mm)	Max.(mm)	Item	Size	Min. (mm)	Max. (mm)
A		4.80	5.00	C3		0.05	0.20
A1		0.356	0.456	C4		0.203	0.233
A2		1.27TYP		D		1.05TYP	
A3		0.345TYP		D1		0.40	0.80
B		3.80	4.00	R1		0.20TYP	
B1		5.80	6.20	R2		0.20TYP	
B2		5.00TYP		$\theta 1$		17° TYP4	
C		1.45	1.55	$\theta 2$		13° TYP4	
C1		0.55	0.65	$\theta 3$		0° ~ 8°	
C2		0.55	0.65	$\theta 4$		4° ~ 12°	

Packing And Ordering Info.

Device Marking and Ordering Information

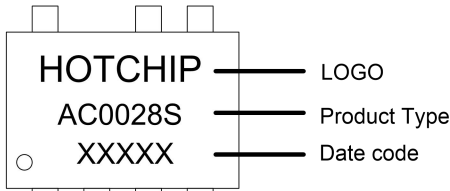

Package	Chip surface marking	Purchasing the device name
SOP7 Pb-free	AC0028S	AC0028S

TAPE AND REEL INFORMATION QUADRANT ASSIGNMENTS FOR PIN1 ORIENTATION TAPE

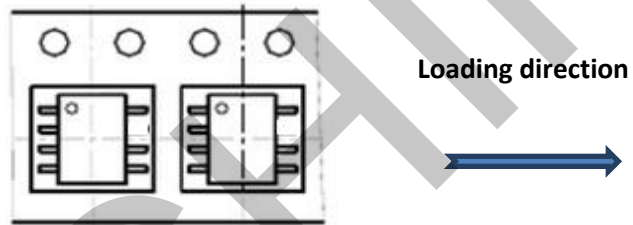
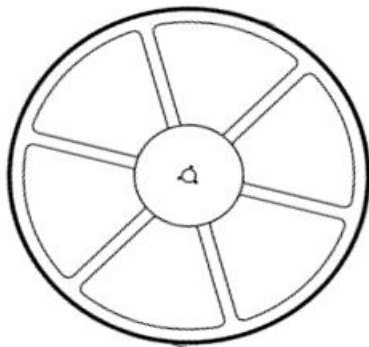

TAPE AND REEL BOX DIMENSIONS

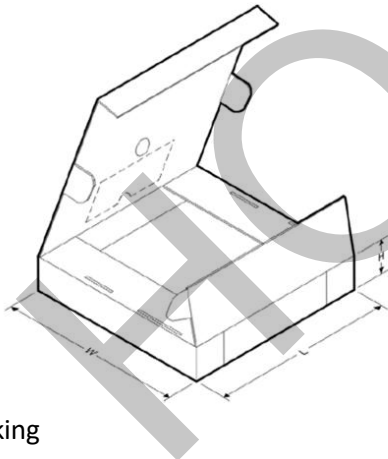

Packing

Inside the box

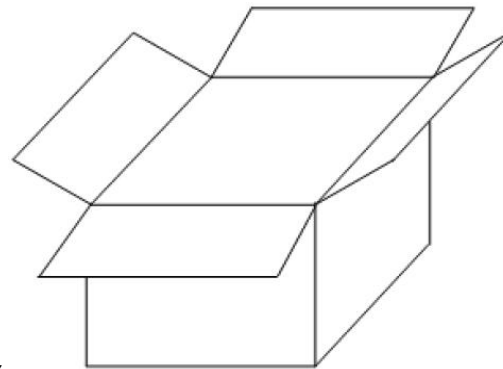

Carton

Package	Packing	Plate size	Each plate number	Number of inner box	Inner box size (L*W*H cm)	Qty	Carton Size (L*W*H cm)
SOP7	Pans	13-inch	4000	2	35.5*34*5	8	42.5*37.5*36

IMPORTANT NOTICE

- ✧ HOTCHIP reserves the right to alter its products without prior notification. For the most up-to-date information, please visit our web site at <http://www.hotchip.com.cn>.
- ✧ HOTCHIP assumes no liability for the issues about the industrial standard, licenses and the right of the third party caused by the electric circuit and chart. The schematic is just for typical application, is not for the specialized mass production application.
- ✧ The export authorization from government is needed when the product or its derivative product do not agree with the Wassenaar Arrangement or other international agreement.
- ✧ Any copy of these information without our permission to print for other uses is forbidden.
- ✧ HOTCHIP's products are not authorized for use as critical components in life support devices or systems, such as motion machine, medical machine, security system, gas equipment, airplane or any other conveyance.
- ✧ HOTCHIP cannot avoid fault or losing efficacy, though we will do the best to improve the quality and reliability. The customers use the products should go through the security design, such as the redundant design, fire protection design, failure protection about the secondary disasters, fire or other related damage.
- ✧ HOTCHIP will continuously provide better products for the customers by all our heart