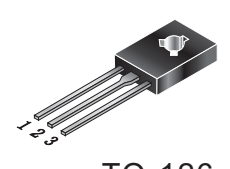

Description

Passivated, sensitive gate triacs in a plastic envelope, intended for use in general purpose bidirectional switching and phase control applications, where high sensitivity is required in all four quadrants.

<p>Symbol</p> 		<p>Simplified outline</p>  <p>TO-126</p>	
Pin	Description		
1	Main terminal 1 (T1)		
2	Main terminal 2 (T2)		
3	gate (G)		
TAB	Main terminal 2 (T2)		

Applications:

- ◆ Motor control
- ◆ Industrial and domestic lighting
- ◆ Heating
- ◆ Static switching

Features

- ◆ Blocking voltage to 600 V
- ◆ On-state RMS current to 8 A

SYMBOL	PARAMETER	Value	Unit
V_{DRM}	Repetitive peak off-state voltages	600	V
$I_{T(RMS)}$	RMS on-state current	8	A
I_{TSM}	Non-repetitive surge current (One full cycle sine wave, 60Hz, $T_j = 125^\circ\text{C}$)	50	A

SYMBOL	PARAMETER	CONDITIONS	MIN	TYP	MAX	UNIT
Rth j-mb	Thermal resistance Junction to mounting base	Full cycle	-	-	3.0	K/W
		Half cycle	-	-	3.7	K/W
Rth j-c	Thermal resistance Junction to Case		-	-	3.0	$^\circ\text{C/W}$



AC05F

Sensitive Gate Triacs

HAOPIN MICROELECTRONICS CO.,LTD.

Limiting values in accordance with the Maximum system(IEC 134)

SYMBOL	PARAMETER	CONDITIONS	MIN	MAX	UNIT
V_{DRM}	Repetitive peak off-state Voltages		-	600	V
$I_{T(RMS)}$	RMS on-state current	$T_c=107^{\circ}C$	-	8	A
V_{DSM}	Non-repetitive peak off Voltage		-	600	V
IT^2dt	Fusing Current	$1ms \leq t \leq 10ms$	-	10	A ² S
DI_T/dt	Repetitive rate of rise of on-state current after trigering		-		
			-	50	A/ μ S
			-	50	A/ μ S
			-	50	A/ μ S
			-	10	A/ μ S
I_{FGM}	Peak gate current	$f \geq 50Hz, Duty \leq 10\%$	-	± 3	A
V_{GM}	Peak gate voltage		-	-	V
P_{GM}	Peak gate power	$f \geq 50Hz, Duty \leq 10\%$	-	3	W
$P_{G(AV)}$	Average gate power		-	0.3	W
T_{stg}	Storage temperature		-40	150	$^{\circ}C$
T_j	Junction Temperature		-40	125	$^{\circ}C$

$T_j=25^{\circ}C$ unless otherwise stated

SYMBOL	PARAMETER	CONDITIONS	MIN	TYP	MAX	UNIT	
Static characteristics							
I_{GT}	Gate trigger current	$V_{DM}=12V; R_L=30\Omega$	I	-	-	5	mA
			II	-	-	5	mA
			III	-	-	5	mA
			Iv	-	-	10	mA
V_{GT}	Gate trigger voltage	$V_{DM}=12V; R_L=30\Omega$	I	-	-	1.5	V
			II	-	-	2.0	V
			III	-	-	1.5	V
			Iv	-	-	1.5	V
I_H	Holding Current	$V_D=24V; I_{TM}=5A$	-	10	-	mA	
V_{GD}	GateNon-Trigger voltage	$T_j=125^{\circ}C, V_{DM}=1/2V_{DRM}$	0.2	-	-	V	
V_{TM}	On-state Voltage	$I_{TM}=5A$	-	-	1.8	V	
I_{DRM}	Peak off-State Current	$V_{DM}=V_{DRM}, T_j=125^{\circ}C$	-	-	1	mA	

Dynamic Characteristics

$(dv/dt)_C$	Commutating dv/dt	$T_j=125^{\circ}C; (di_T/dt)_c=-2.7A/ms$ $V_D=400V$	5	-	-	V/ μ S
t_{gt}	Gate controlled turn-on time		-	2	-	μ S

Description

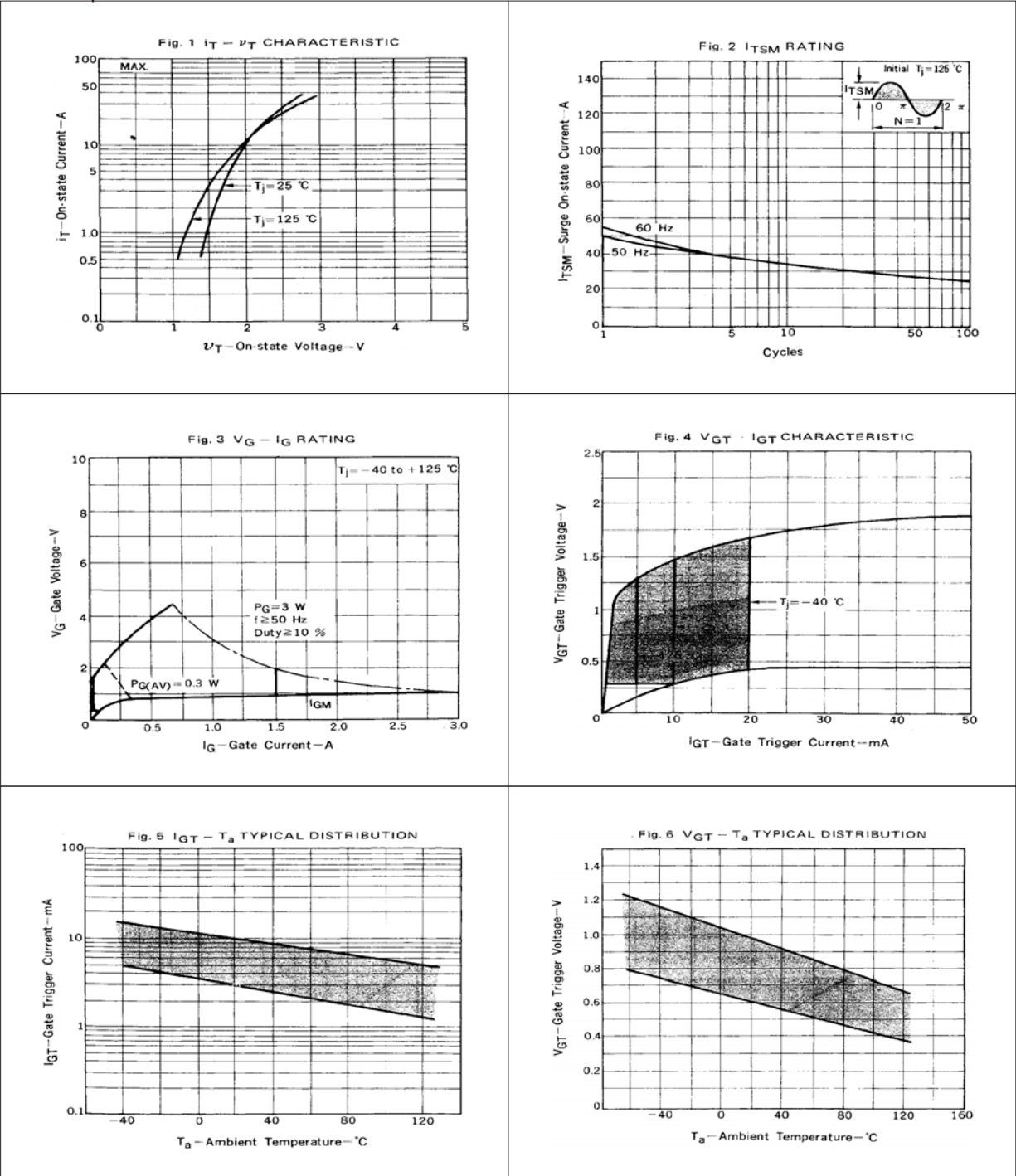

Description

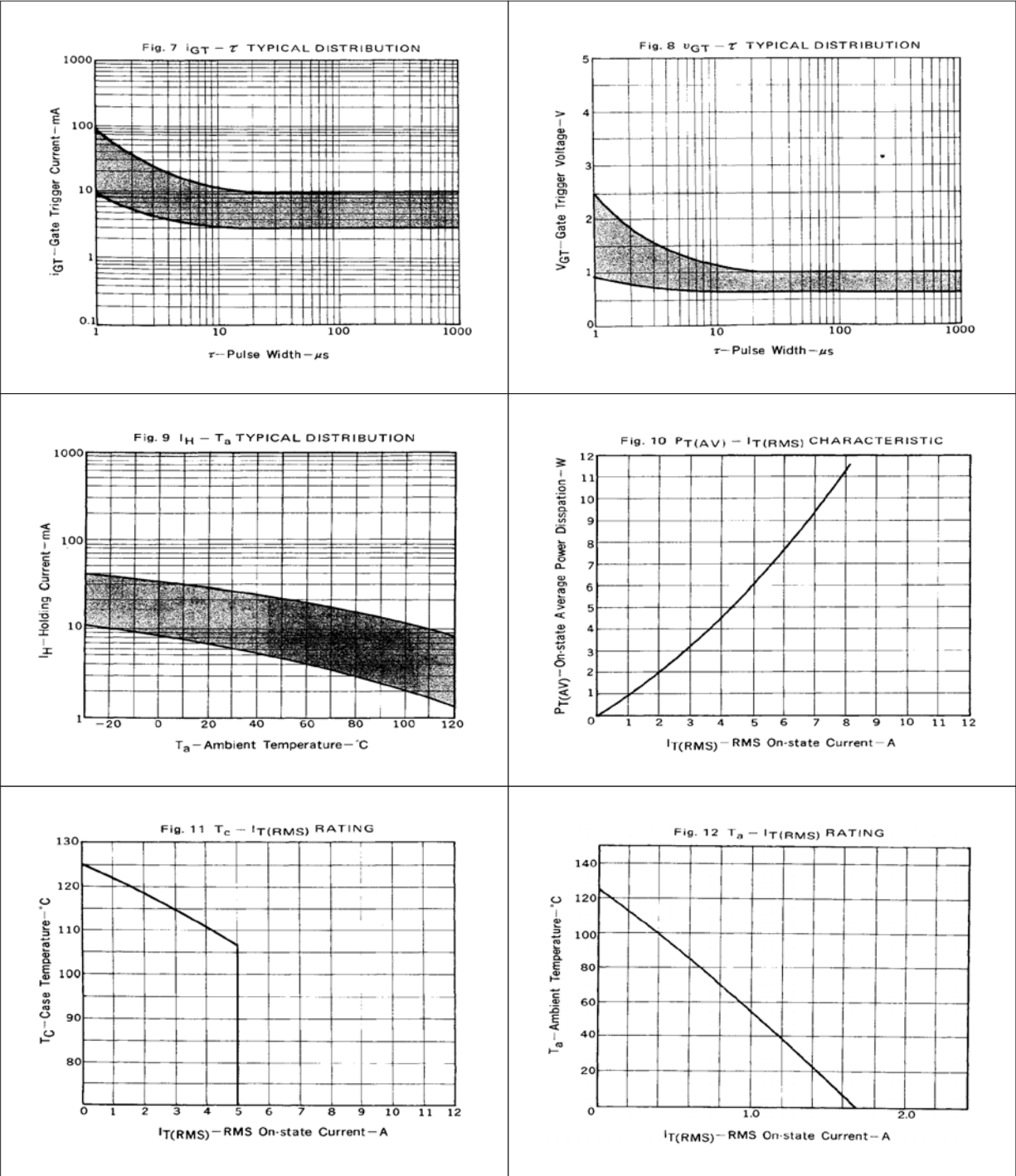

Description

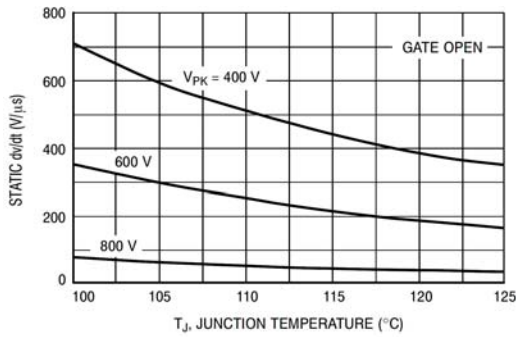

Figure 13. Typical Exponential Static dv/dt versus Junction Temperature, MT2(+)

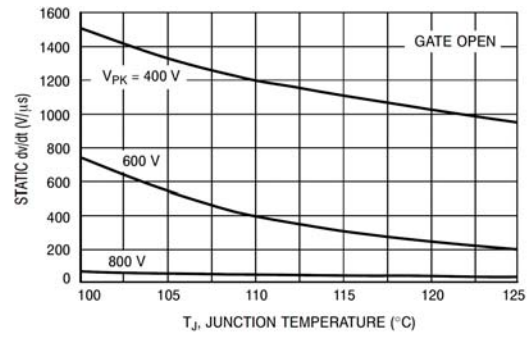

Figure 14. Typical Exponential Static dv/dt versus Junction Temperature, MT2(-)

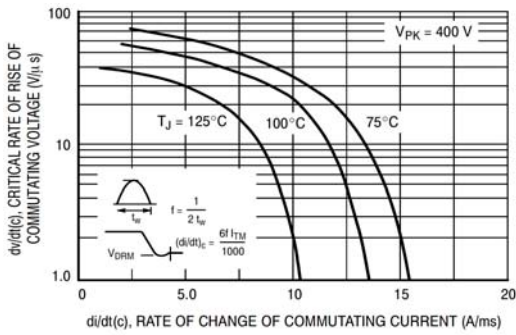

Figure 15. Critical Rate of Rise of Commutating Voltage

MECHANICAL DATA

Dimensions in mm

Net Mass:0.7 g

TO-126

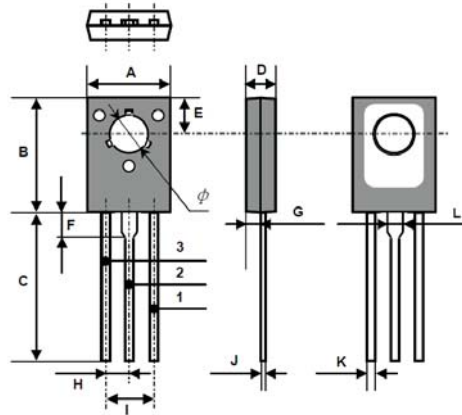

TO-126 Package Dimension

Dim.	mm			Inch		
	Min.	Typ.	Max.	Min.	Typ.	Max.
A	7.5		7.9	0.295		0.311
B	10.8		11.2	0.425		0.441
C	14.2		14.7	0.559		0.579
D	2.7		2.9	0.106		0.114
E		3.8			0.150	
F		2.5			0.098	
G	1.2		1.5	0.047		0.059
H		2.3			0.091	
I		4.6			0.181	
J	0.48		0.62	0.019		0.024
K	0.7		0.86	0.028		0.034
L		1.4			0.055	
phi		3.2			0.126	