



AC2233W 700MHz-2700MHz BroadBand Power Amplifier

RoHS & Pb-Free Product

Features

- 700~2700MHz Operating Range
- 3.3~5.0V Operation
- 26dB Gain (Typ)@1.6GHz
- 35dBm P1dB @VCC=5V
- 280mA Quiescent Current
- >15dB Input Return Loss
- Integrated Output Power Detector
- ESD protection all ports above 1000V HBM

Product Description

The AC2233W is a high dynamic range broadband power amplifier in a surface mount package. The two-stage amplifier provides a typical gain of 26dB, while being able to achieve high performance for 0.7–2.7 GHz applications with up to +35dBm of compressed 1dB power, typical bias condition is 5V at 280mA.

The device is manufactured on an advanced InGaP Heterojunction Bipolar Transistor (HBT) process. The device incorporates proprietary bias circuitry to compensate for variations in linearity and current draw over temperature.

The AC2233W is assembled in a 16-pin, 4mm×4mm, QFN package. It is internally integrated with ESD protection circuitry on all ports.

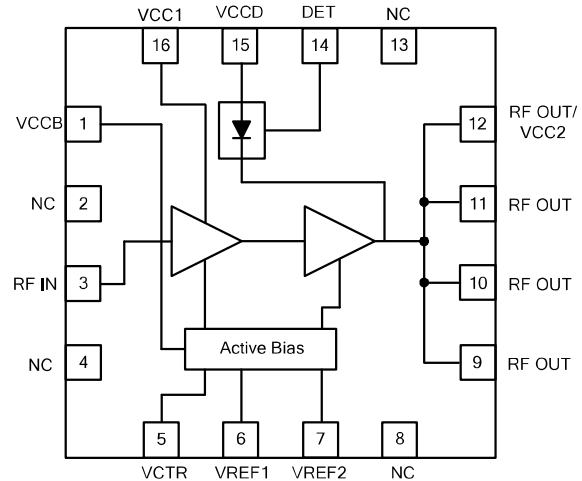

Functional Block Diagram

Applications

- 802.11b/g/n Access Point
- 2.4GHz ISM Wireless Equipment
- PCS Communication Systems
- Broadband Spread-Spectrum Systems
- High Power Amplifiers Application
- Final Stage Amplifiers for repeaters
- MDAS/Small Cell

Ordering Information

- | | |
|-----------------|-----------------------------|
| ■ AC2233W | BroadBand Power Amplifier |
| ■ AC2233W EVB-1 | 1.2-1.3GHz Evaluation Board |
| ■ AC2233W EVB-2 | 1.5-1.7GHz Evaluation Board |
| ■ AC2233W EVB-3 | 2.4-2.5GHz Evaluation Board |

AC2233W 700MHZ-2700MHz BroadBand Power Amplifier

Pin Description

Pin No.	Symbol	Description
1	VCCB	Supply voltage for bias
3	RF IN	RF input
5	VCTR	Power on/off control voltage
6, 7	VREF1, VREF2	Bias current control voltage
9, 10, 11, 12	RF OUT (VCC2)	RF output and stage 2 collector voltage
14	DET	Output power detect
15	VCCD	Supply voltage for power detector
16	VCC1	Stage 1 collector voltage
2, 4, 8, 13	NC/GND	No connection or ground

Absolute Maximum Ratings

Parameter	Rating	Unit
Input RF Power	+20	dBm
Supply Voltage	-0.5 to +8.0	V
Bias Voltage	-0.5 to +3.0	V
DC Supply Current	2000	mA
Operating Ambient Temperature	-40 to +85	°C
Storage Temperature	-40 to +150	°C



Caution! ESD Sensitive Device.

ESD Rating: Class1C
 Value: Passes $\geq 1000V$ min.
 Test: Human Body Model (HBM)
 Standard: JEDEC Standard JESD22-A114

ESD Rating: Class IV
 Value: Passes $\geq 1000V$ min.
 Test: Charged Device Model (CDM)
 Standard: JEDEC Standard JESD22-C101

MSL Rating: Level 3 at +260 °C convection reflow
 Standard: JEDEC Standard J-STD-020

Electrical Specifications

Parameter	Specification			Unit	Condition
	Min.	Typ.	Max.		
Frequency Range	1.2		1.3	GHz	
Output Power@1dB Compression	33.5	34	34.5	dBm	VCC=5V@1.25GHz
Gain	26.5	27	27.5	dB	VCC=5V@1.25GHz
Power Supply					
Operating Voltage		5.0		V	
Reference Voltage 1(VR1)		2.65		V	
Reference Voltage 2(VR2)		2.65		V	
Quiescent Current (Total)		240		mA	VCC1=VCC2=VCCB=5V,

AC2233W 700MHZ-2700MHz BroadBand Power Amplifier

					VR1=VR2=2.65V
--	--	--	--	--	---------------

Parameter	Specification			Unit	Condition
	Min.	Typ.	Max.		
Frequency Range	1.6		1.65	GHz	
Output Power@1dB Compression	34.5	35	35.5	dBm	VCC=5V@1.63GHz
Gain	25.5	26	26.5	dB	VCC=5V@1.63GHz
Power Supply					
Operating Voltage		5.0		V	
Reference Voltage 1(VR1)		2.68		V	
Reference Voltage 2(VR2)		2.68		V	
Quiescent Current (Total)		280		mA	VCC1=VCC2=VCCB=5V, VR1=VR2=2.68V

AC2233W 700MHz-2700MHz BroadBand Power Amplifier

Typical Performance: (Frequency range: 870MHz~890MHz)

Narrowband Gain & Return Loss

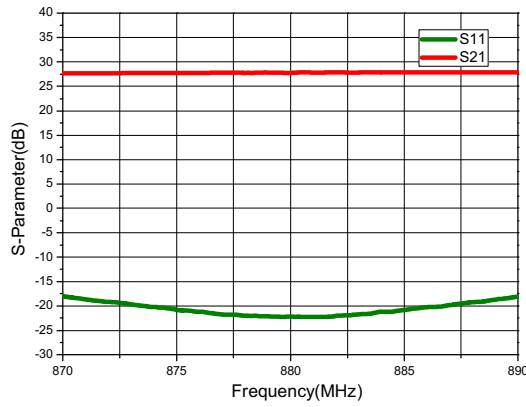

Power Gain vs. Input Power

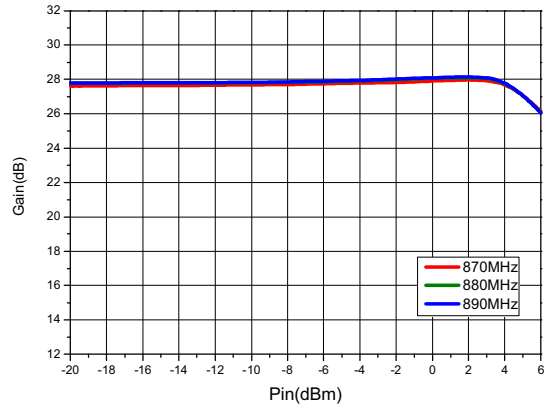

P1dB vs. Frequency

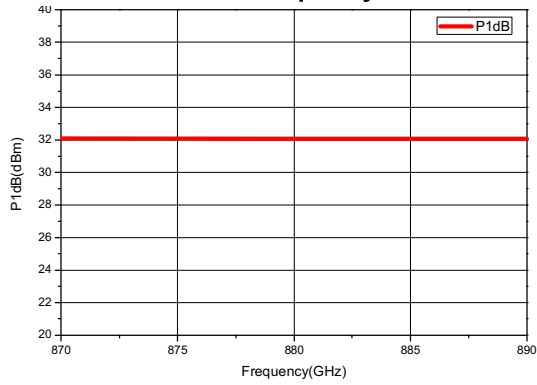

AC2233W 700MHz-2700MHz BroadBand Power Amplifier

Application Schematic: (Frequency range: 870MHz~890MHz)

(Test Condition: **VCC=5.0V**, **VREF=2.78V**, **ICC=340mA**, **T=25°C**)

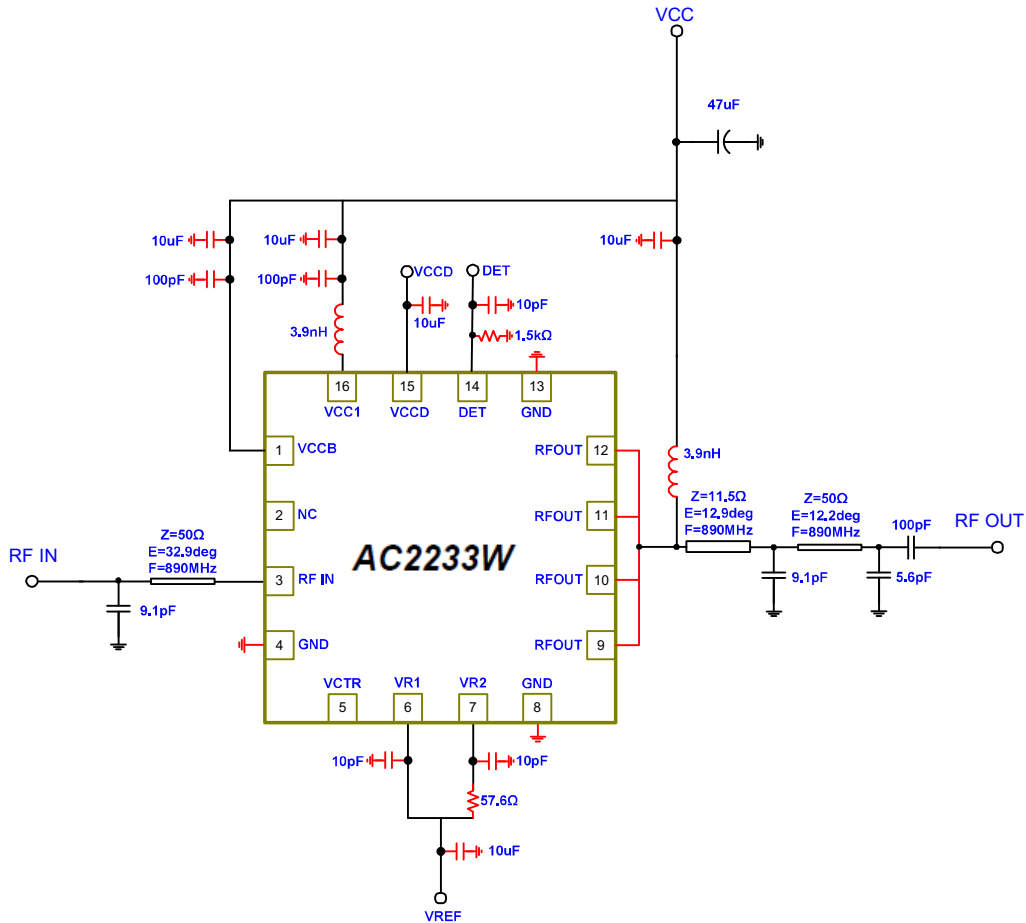

Notes:

1. Pin5 is power down pin. Apply $>1.5 V_{DC}$ to power down the three power amplifier stages. Apply $0V_{DC}$ to power up. If function is not desired, pin5 may be connected to GND.
2. Pin14, 15 are active power detection circuit ports, if function is not desired, pin14, 15 may be left unterminated (open) .

Evaluation Board Layout :(Frequency range: 870MHz~890MHz)

Board Size 50mm×50mm, Board Thickness 1mm, Board Material FR-4 ($\epsilon_r=4.5$)

Evaluation Board Top View

Layer Detail Physical Characteristics

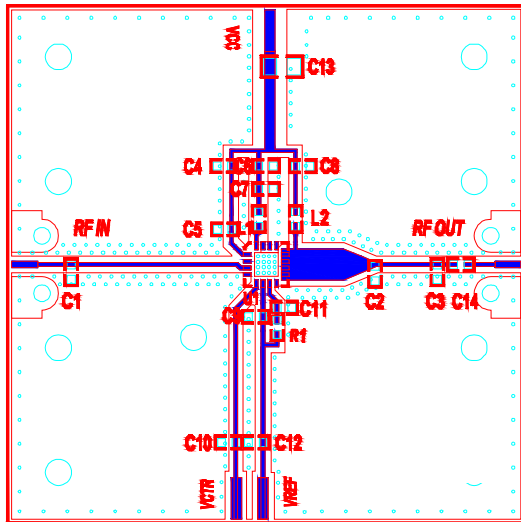

Cross Section	Name	Thickness	Material	ϵ_r
Via14	RFS	1oz	Cu	--
	Core 1	0.23mm	FR-4	4.5
	RFGND	1oz	Cu	--
			FR-4	4.5
	PCS	1oz	Cu	--
			FR-4	4.5
	GND	1oz	Cu	--

Circuit Component Designations and Values

Component	Description	Manufacturer
L1,L2	3.9nH Inductor	ATC
C1,C2	9.1pF Chip Capacitor	DLC
C3	5.6pF Chip Capacitor	DLC
C5,C7, C9, C11,C14	100pF Chip Capacitor	TDK
C4,C6,C8,C10,C12	10uF Chip Capacitor	TDK
C13	47uF Capacitor	AVX
R1	57.6ohm	TDK

Typical Performance (Frequency range: 1.2GHz~1.3GHz)

Narrowband Gain & Return Loss

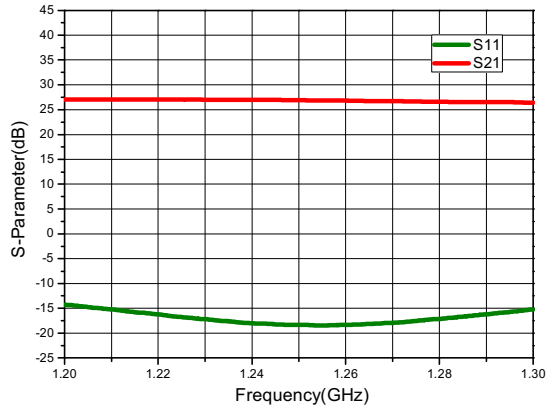

Power Gain vs. Input Power

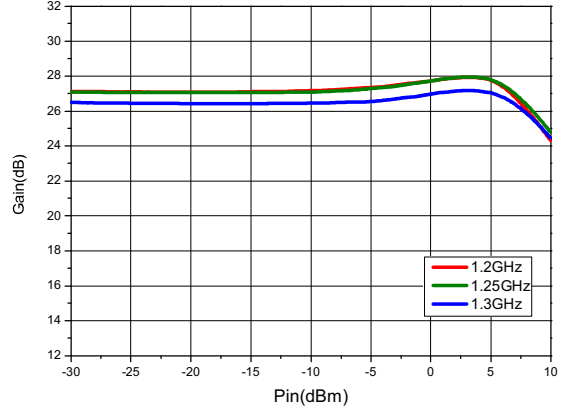

P1dB vs. Frequency

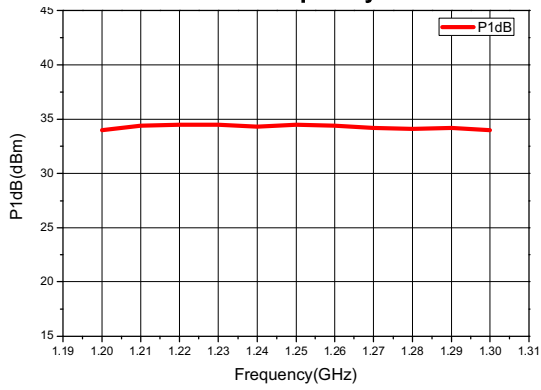

AC2233W 700MHz-2700MHz BroadBand Power Amplifier

Application Schematic: (Frequency range: 1.2GHz~1.3GHz)

(Test Condition: **VCC=5.0V**, **VREF=2.65V**, **ICC=240mA**, **T=25°C**)

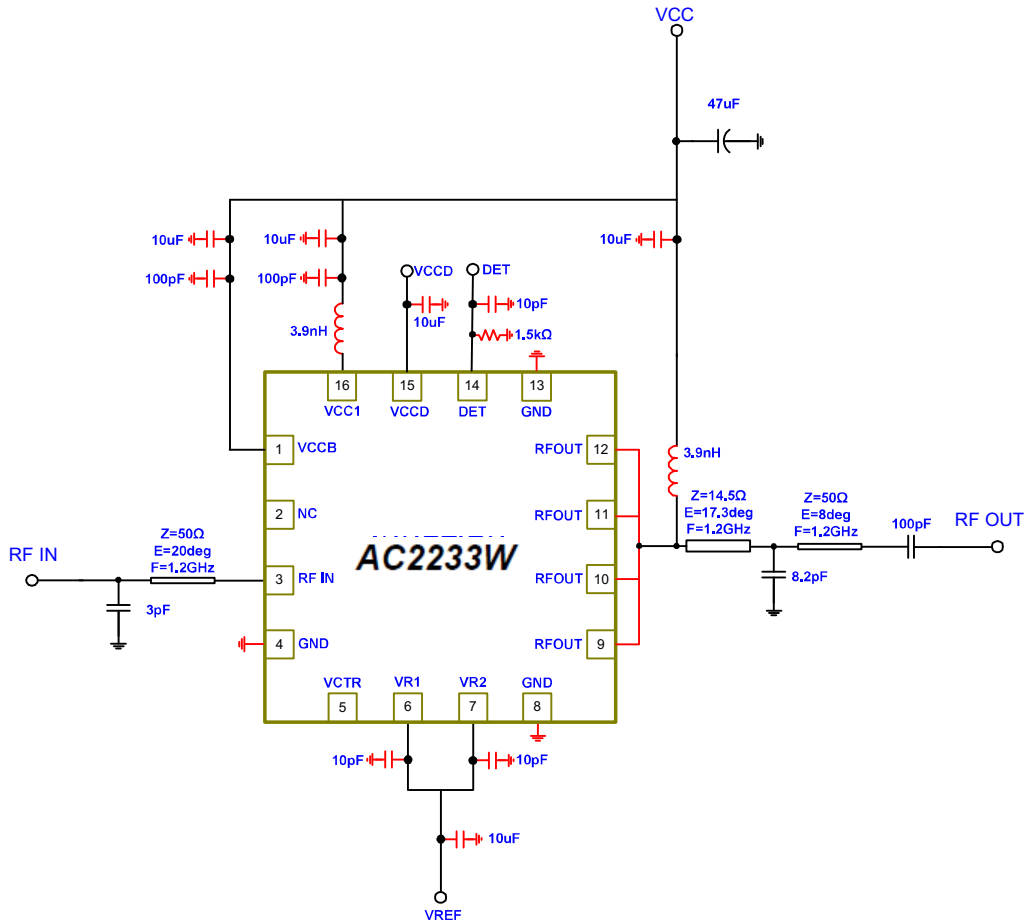

Notes:

1. Pin5 is power down pin. Apply $>1.5 V_{DC}$ to power down the three power amplifier stages. Apply $0V_{DC}$ to power up. If function is not desired, pin5 may be connected to GND.
2. Pin14, 15 are active power detection circuit ports, if function is not desired, pin14, 15 may be left unterminated (open) .

Evaluation Board Layout : (Frequency range: 1.2GHz~1.3GHz)

Board Size 50mm×50mm, Board Thickness 1mm, Board Material FR-4 ($\epsilon_r=4.5$)

Evaluation Board Top View

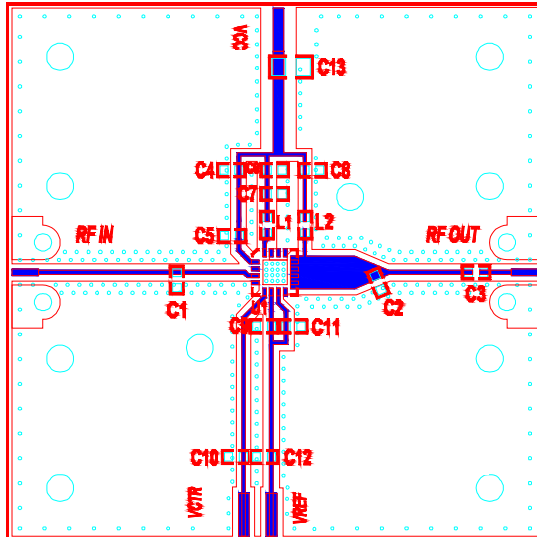

Layer Detail Physical Characteristics

Cross Section	Name	Thickness	Material	ϵ_r
Via14	RFS	1oz	Cu	--
	Core1	0.23mm	FR-4	4.5
	RFGND	1oz	Cu	--
			FR-4	4.5
	PCS	1oz	Cu	--
			FR-4	4.5
	GND	1oz	Cu	--

Circuit Component Designations and Values

Component	Description	Manufacturer
L1,L2	3.9nH Inductor	ATC
C1	3pF Chip Capacitor	DLC
C2	8.2pF Chip Capacitor	DLC
C3,C5,C7, C9, C11	100pF Chip Capacitor	TDK
C4,C6,C8,C10,C12	10uF Chip Capacitor	TDK
C13	47uF Capacitor	AVX

Typical Performance (Frequency range: 1.6GHz~1.63GHz)

Narrowband Gain & Return Loss

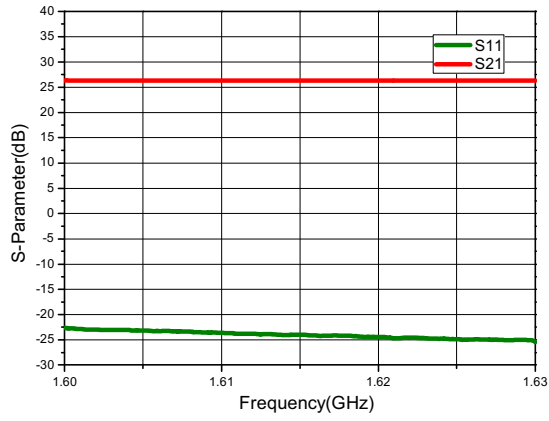

Power Gain vs. Input Power

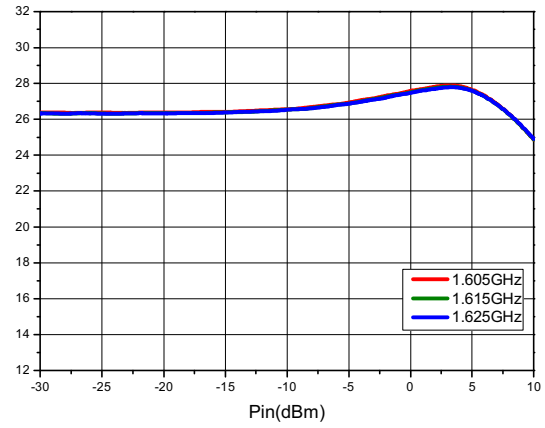

P1dB vs. Frequency

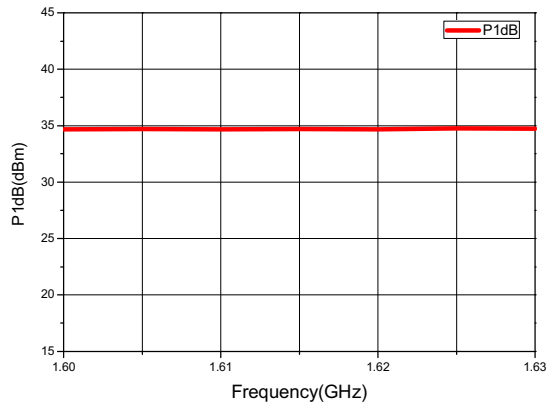

AC2233W 700MHZ-2700MHz BroadBand Power Amplifier

Application Schematic: (Frequency range: 1.6GHz~1.63GHz)

(Test Condition: **VCC=5.0V**, **VREF=2.68V**, **ICC=280mA**, **T=25°C**)

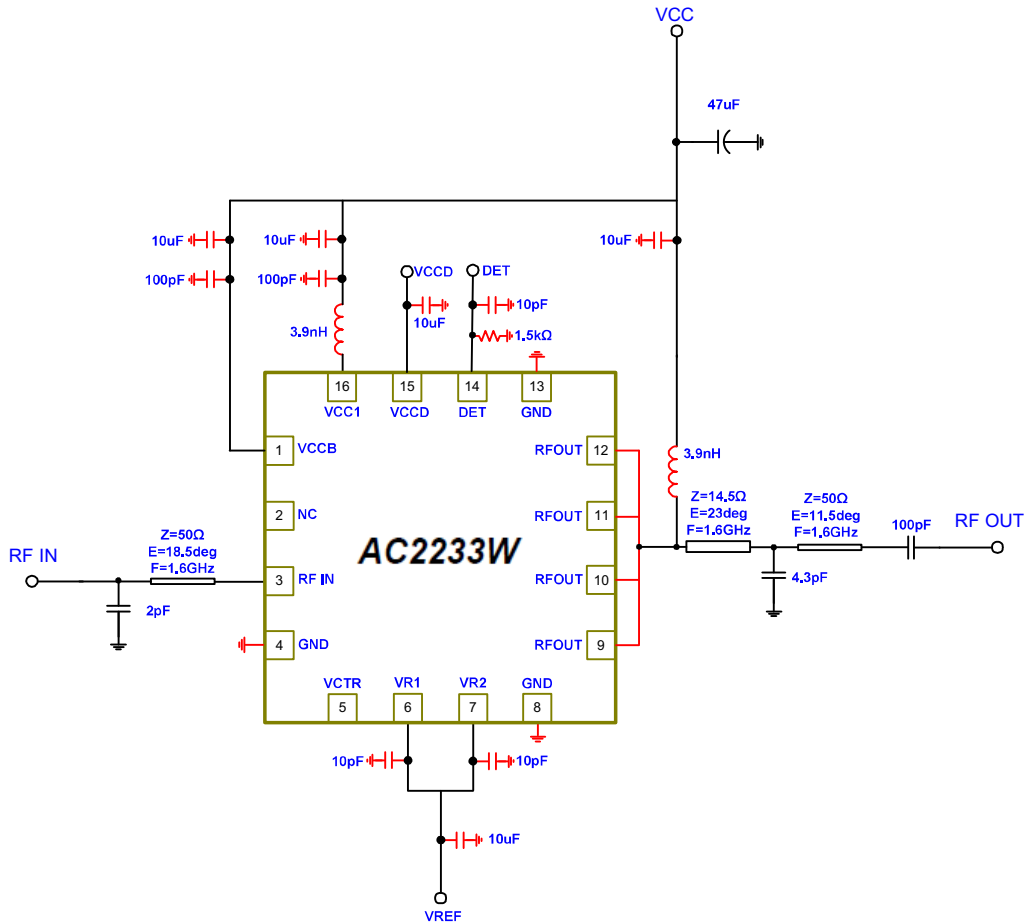

Notes:

1. Pin5 is power down pin. Apply $>1.5 V_{DC}$ to power down the three power amplifier stages. Apply $0V_{DC}$ to power up. If function is not desired, pin5 may be connected to GND.
2. Pin14, 15 are active power detection circuit ports, if function is not desired, pin14, 15 may be left unterminated (open) .

Evaluation Board Layout : (Frequency range: 1.6GHz~1.63GHz)

Board Size 50mm×50mm, Board Thickness 1mm, Board Material FR-4 ($\epsilon_r=4.5$)

Evaluation Board Top View

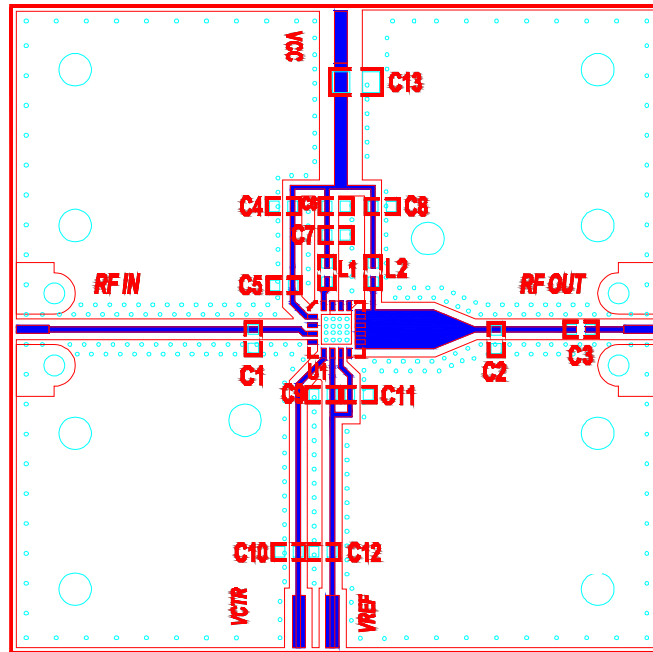

Circuit Component Designations and Values

Component	Description	Manufacturer
L1,L2	3.9nH Inductor	ATC
C1	2pF Chip Capacitor	DLC
C2	4.3pF Chip Capacitor	DLC
C3,C5,C7, C9, C11	100pF Chip Capacitor	TDK
C4,C6,C8,C10,C12	10uF Chip Capacitor	TDK
C13	47uF Capacitor	AVX

Typical Performance (Frequency range: 1.9GHz~2.0GHz)

Narrowband Gain & Return Loss

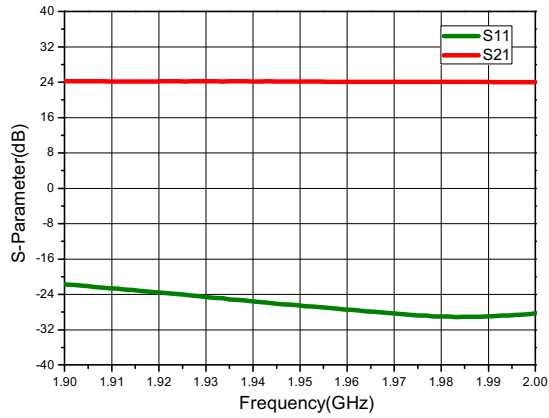

Power Gain vs. Input Power

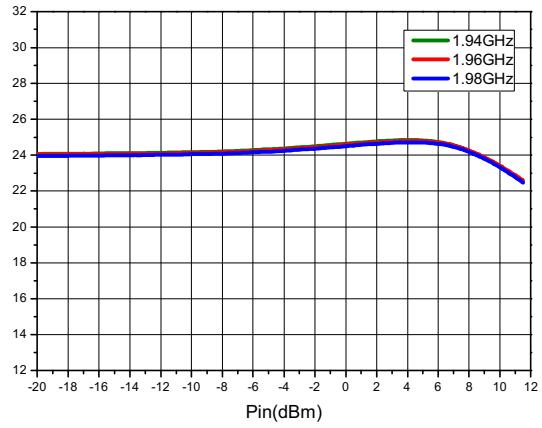

P1dB vs. Frequency

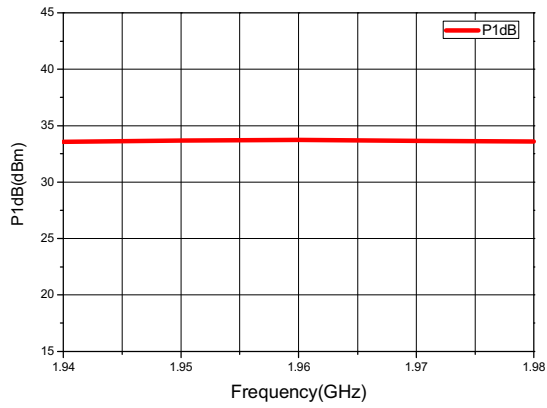

AC2233W 700MHz-2700MHz BroadBand Power Amplifier

Application Schematic: (Frequency range: 1.9GHz~2.0GHz)

(Test Condition: **VCC=5.0V**, **VREF=2.78V**, **ICC=340mA**, **T=25°C**)

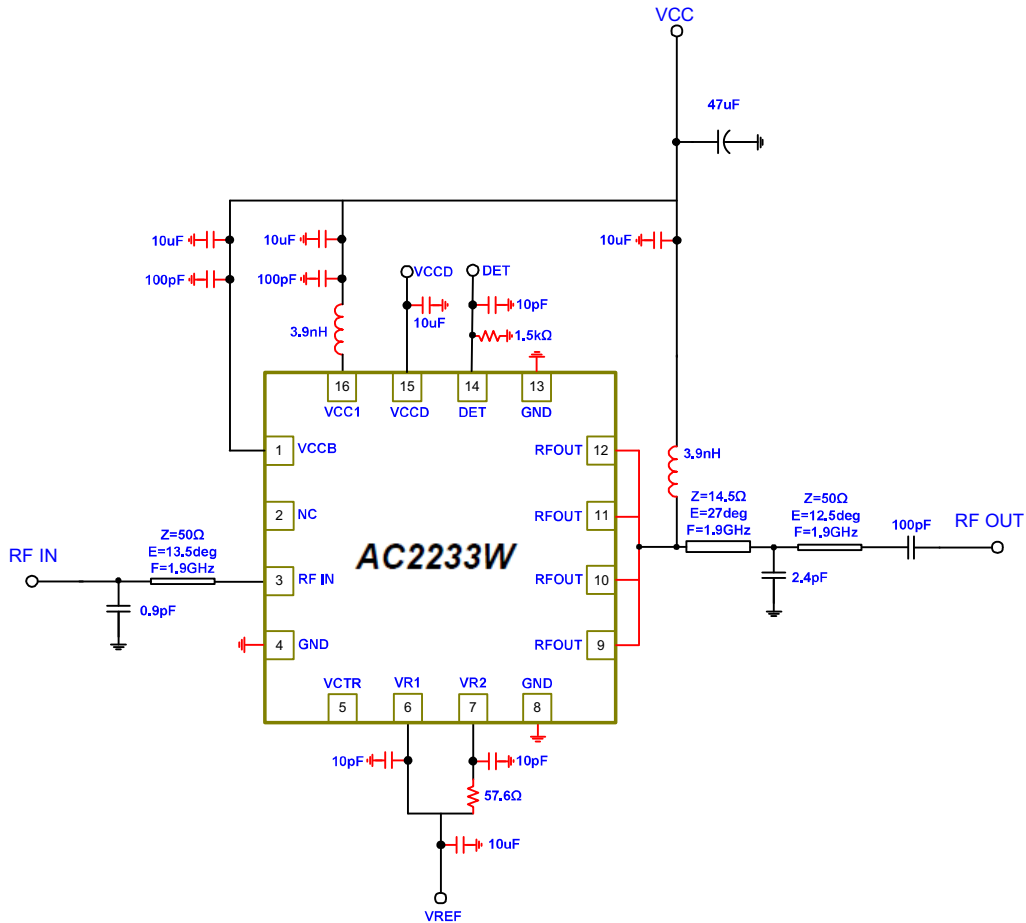

Notes:

1. Pin5 is power down pin. Apply $>1.5 V_{DC}$ to power down the three power amplifier stages. Apply $0V_{DC}$ to power up. If function is not desired, pin5 may be connected to GND.
2. Pin14, 15 are active power detection circuit ports, if function is not desired, pin14, 15 may be left unterminated (open) .

Evaluation Board Layout: (Frequency range: 1.9GHz~2.0GHz)

Board Size 50mm×50mm, Board Thickness 1mm, Board Material FR-4 ($\epsilon_r=4.5$)

Evaluation Board Top View

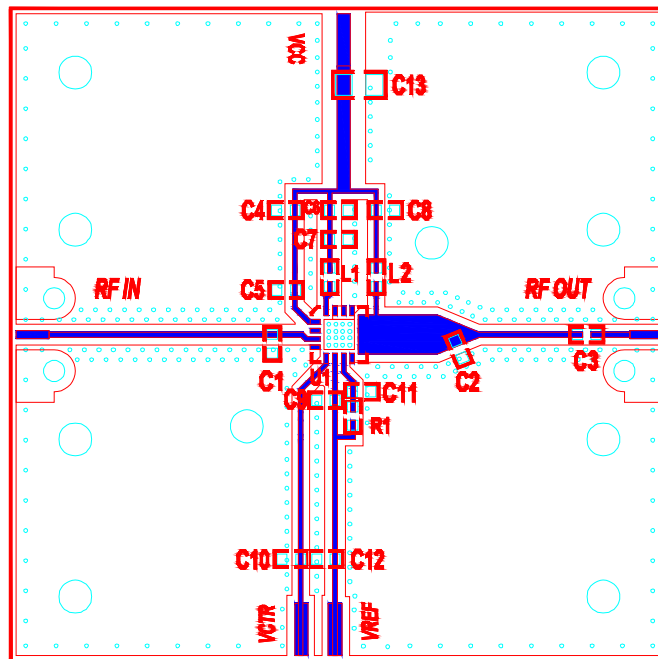

Circuit Component Designations and Values

Component	Description	Manufacturer
L1,L2	3.9nH Inductor	ATC
C1	0.9pF Chip Capacitor	DLC
C2	2.4pF Chip Capacitor	DLC
C3,C5,C7, C9, C11	100pF Chip Capacitor	TDK
C4,C6,C8,C10,C12	10uF Chip Capacitor	TDK
C13	47uF Capacitor	AVX
R1	57.6ohm	TDK

Typical Performance (Frequency range: 2.1GHz~2.2GHz)

Narrowband Gain & Return Loss

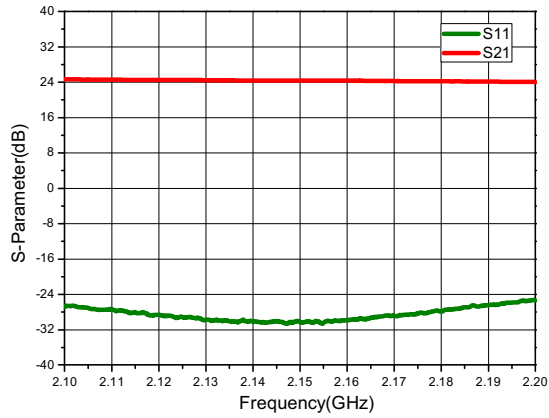

Power Gain vs. Input Power

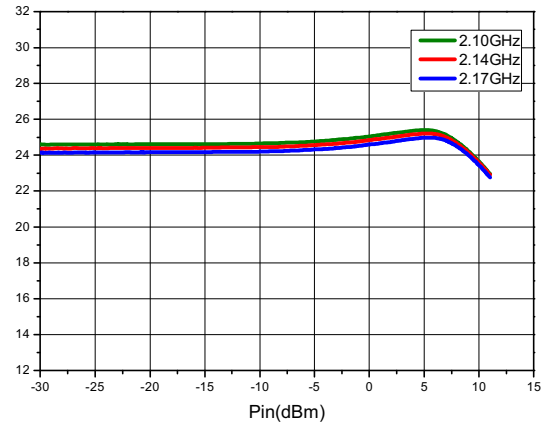

P1dB vs. Frequency

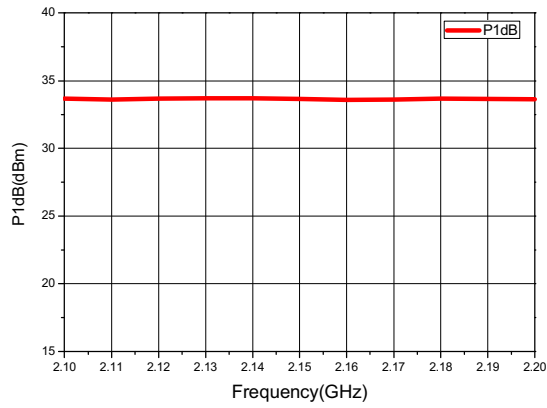

AC2233W 700MHz-2700MHz BroadBand Power Amplifier

Application Schematic: (Frequency range: 2.1GHz~2.2GHz)

(Test Condition: **VCC=5.0V**, **VREF=2.83V**, **ICC=440mA**, **T=25°C**)

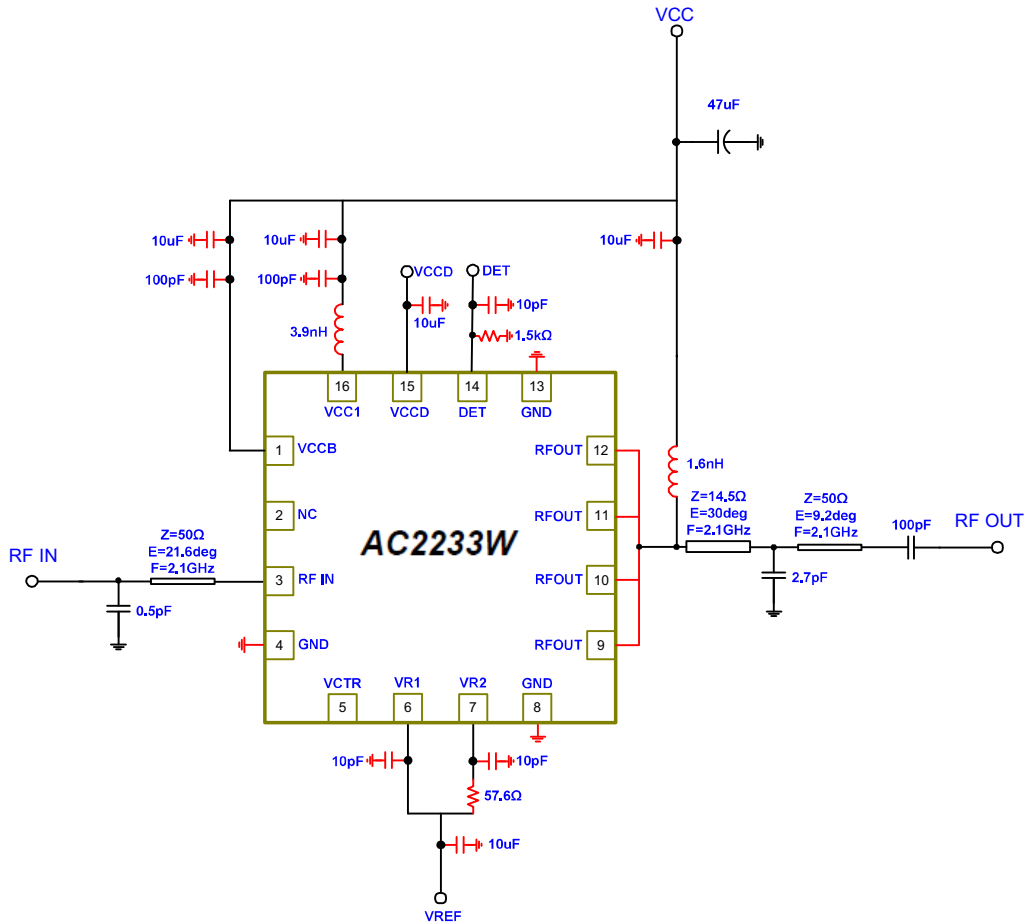

Notes:

1. Pin5 is power down pin. Apply $>1.5 V_{DC}$ to power down the three power amplifier stages. Apply $0V_{DC}$ to power up. If function is not desired, pin5 may be connected to GND.
2. Pin14, 15 are active power detection circuit ports, if function is not desired, pin14, 15 may be connected to GND.

Evaluation Board Layout: (Frequency range: 2.1GHz~2.2GHz)

Board Size 50mm×50mm, Board Thickness 1mm, Board Material FR-4 ($\epsilon_r=4.5$)

Evaluation Board Top View

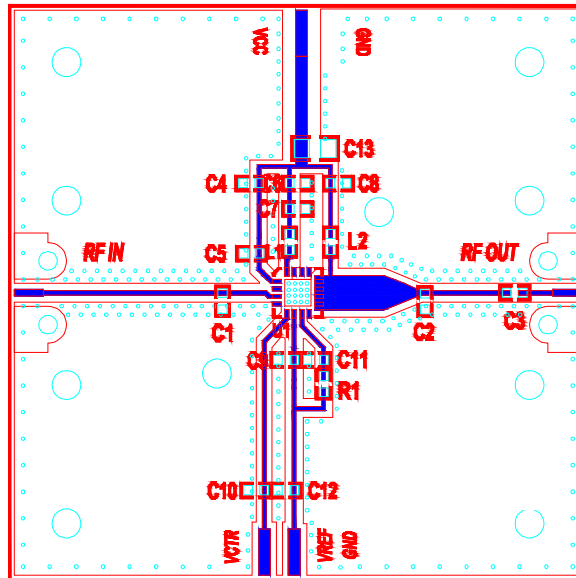

Circuit Component Designations and Values

Component	Description	Manufacturer
L1	3.9nH Inductor	ATC
L2	1.6nH Inductor	ATC
C1	0.5pF Chip Capacitor	DLC
C2	2.7pF Chip Capacitor	DLC
C3,C5,C7, C9, C11	100pF Chip Capacitor	TDK
C4,C6,C8,C10,C12	10uF Chip Capacitor	TDK
C13	47uF Capacitor	AVX
R1	57.6ohm	TDK

AC2233W 700MHZ-2700MHz BroadBand Power Amplifier

Packaging Diagram

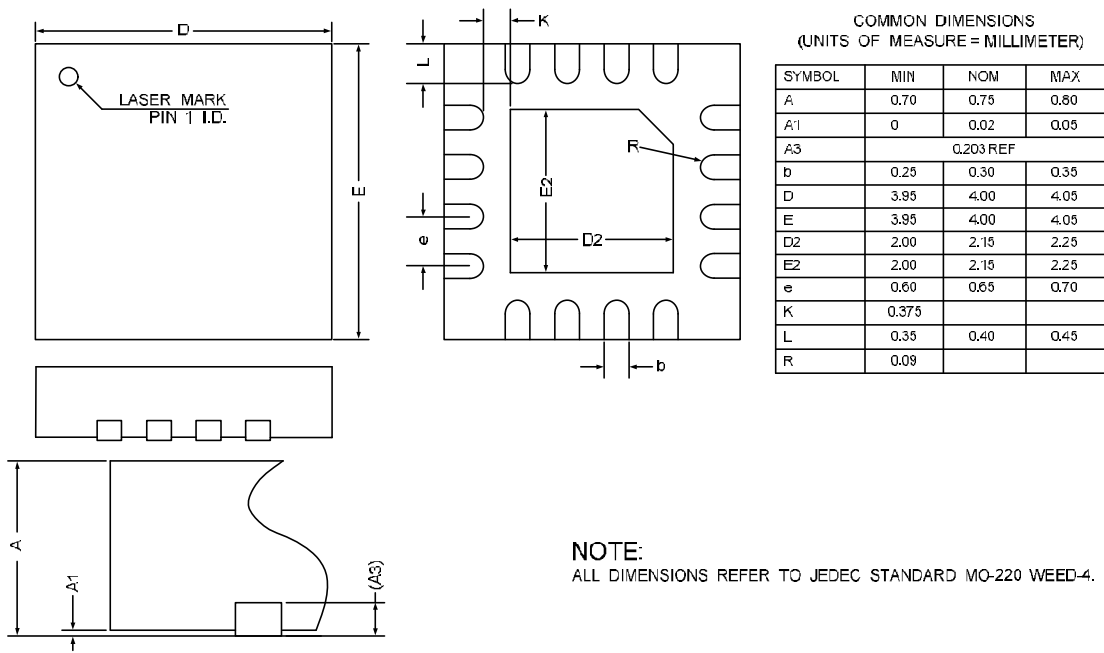

PCB Land Pattern and Stencil Outline

(Units: millimeters)

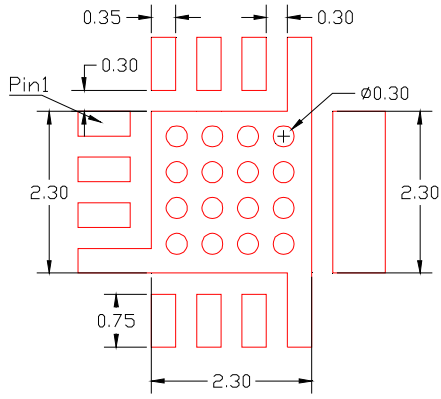

PCB Land Pattern (Top View)

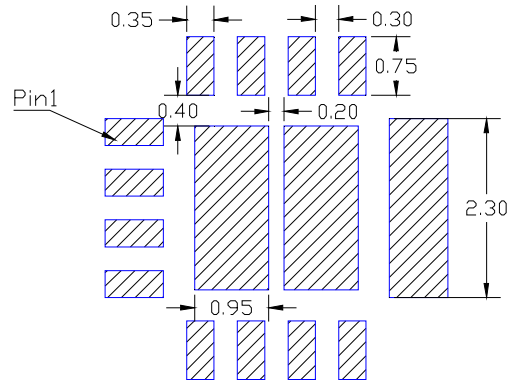

Stencil Outline

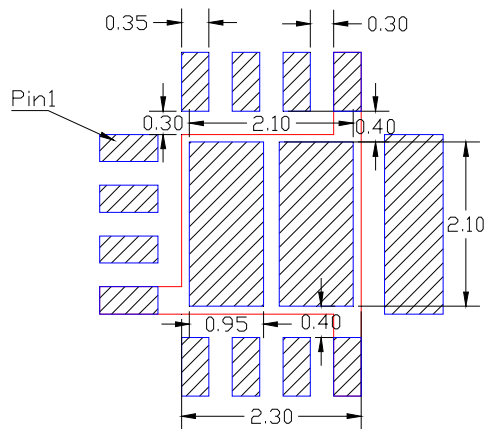

Combined PCB Land Pattern and Stencil Outline

Recommended Solder Temperature

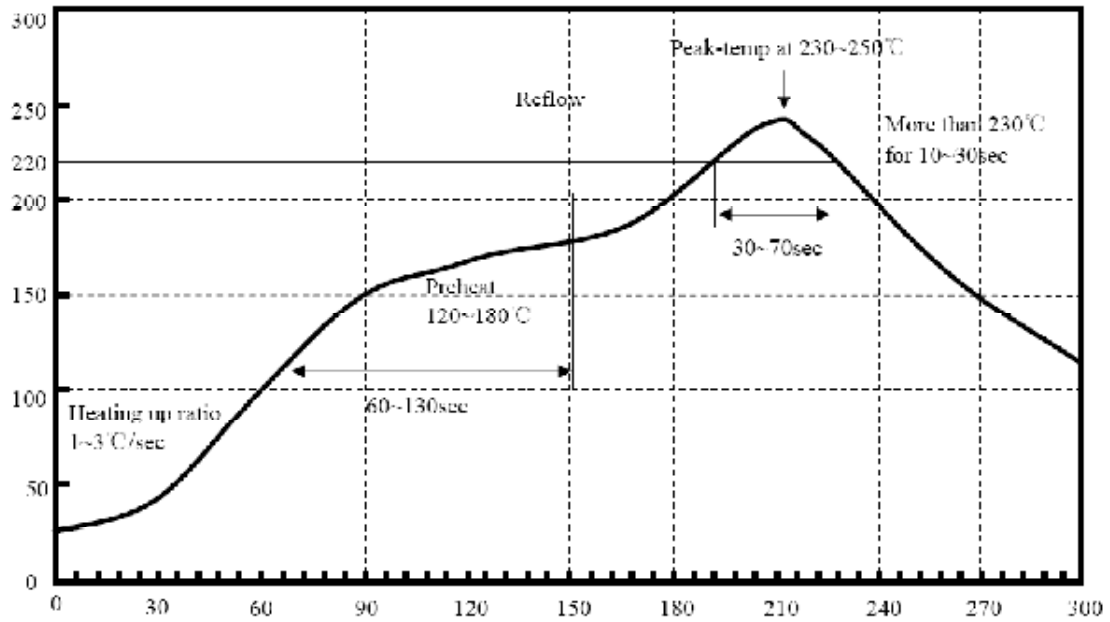

Recommended Temperature

Sn95.5Ag4.0Cu0.5

Tape dimensions and Orientation

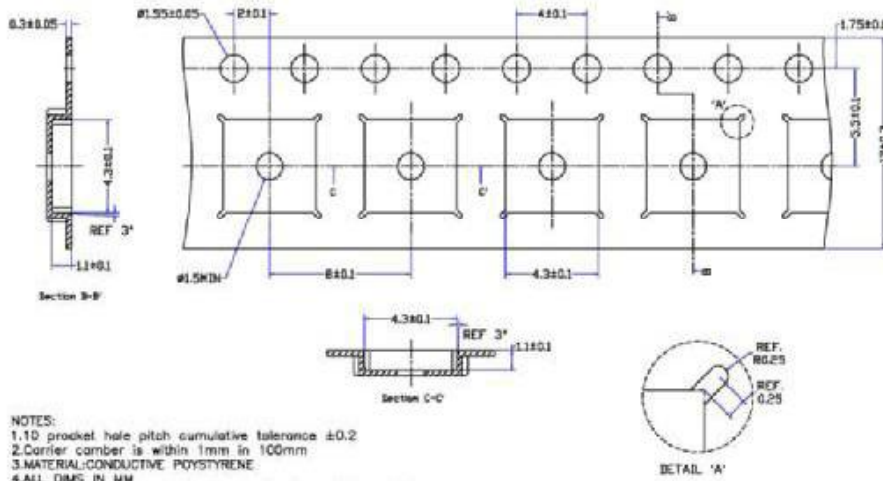

- NOTES:**
 1.10 pocket hole pitch cumulative tolerance ±0.2
 2.Carrier camber is within 1mm in 100mm
 3.MATERIAL:CONDUCTIVE POLYSTYRENE
 4.ALL DIMS IN MM
 5.There must not be foreign body adhesion and the state of the surface must be excellent
 6.17" PAPER-Reel, 51875pockets
 7.Surface resistance 1X10E11(max) OHMS/SQ

Reel dimensions and Orientation

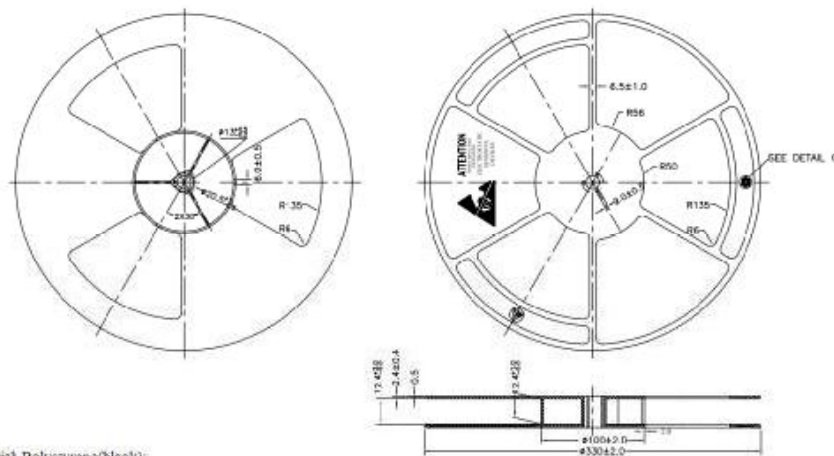

- Notes:**
 1. Material Polystyrene(black);
 2. Surface flatness: Maximum permissible error is 3mm;
 3. Dimensions in millimeters;
 4. Surface resistance: 10⁵ TO 10¹⁰ OHMS/SQ;
 5. General tolerances: ±0.24