

## Features

- Operating Frequency 50MHz to 6GHz
- 18dB Gain at 2.0GHz
- 22dBm P1dB at 2.0GHz
- 32dBm OIP3 at 2.0GHz
- Single Power Supply
- Integrated Active Bias Circuit
- Industry Standard SOT-89 Package
- ESD protection all ports above 1000V HBM

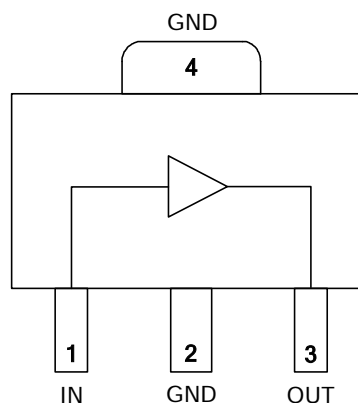

**Functional Block Diagram**

## Applications

- WLAN / WiMAX / WiBro
- GSM / CDMA / PCS
- WCDMA / LTE
- GPS / COMPASS
- CMMB
- RFID
- CATV
- ISM

## Product Description

The AC602020 is a high performance InGaP/GaAs HBT MMIC gain block amplifier utilizing a Darlington pair configuration with an active bias network. The active bias network provides stable current over temperature and process variations. The AC602020 is internally matched to 50Ω, its typical bias condition is a single 5V, and does not require a dropping resistor as compared to typical Darlington amplifiers. The AC602020 is assembled in an industry standard SOT-89 package. It is internally integrated with ESD protection unit.

## Pin Description

Pin No.	Symbol	Description
1	IN	RF input
3	OUT	RF output and bias
2, 4	GND	Ground connected

## Absolute Maximum Ratings

Parameter	Rating	Unit
Input RF Power	+15	dBm
Supply Voltage	-0.5 to +6.0	V
Device Current	200	mA
Operating Ambient Temperature	-40 to +85	°C
Storage Temperature	-40 to +150	°C



### Caution!

Exceeding any one or a combination of the Absolute Maximum Rating conditions may cause permanent damage to the device. Extended application of Absolute Maximum Rating conditions to the device may reduce device reliability.

## Electrical Specifications

Parameter	Specification			Unit	Condition
	Min.	Typ.	Max.		
Small Signal Gain		15.4		dB	2450MHz
		18.0		dB	2000MHz
		23.4		dB	900MHz
		26.9		dB	433MHz
P1dB Output Power		21.0		dBm	2450MHz
		22.2		dBm	2000MHz
		20.2		dBm	900MHz
		18.0		dBm	433MHz
Input Return Loss		-27.0		dB	2450MHz
		-20.1		dB	2000MHz
		-12.6		dB	900MHz
		-12.3		dB	433MHz
Output Return Loss		-9.1		dB	2450MHz
		-7.4		dB	2000MHz
		-19.6		dB	900MHz
		-10.6		dB	433MHz
Reverse Isolation		25.7		dB	2450MHz
		27.9		dB	2000MHz
		30.6		dB	900MHz
		30.9		dB	433MHz
OIP3 <sup>1)</sup>		32.5		dBm	2450MHz
		32.3		dBm	2000MHz
		31.2		dBm	900MHz
		30.5		dBm	433MHz
Noise Figure		4.0		dB	2400MHz
Supply Voltage		5.0		V	
Device Current		72		mA	

1) OIP3 measured with two tones at an output power of 0dBm/ tone separated by 1MHz.

## Typical Performance

### WLAN (2400~2500MHz) Application:

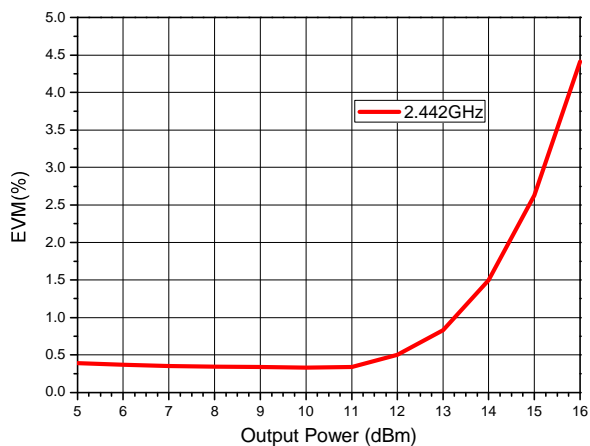
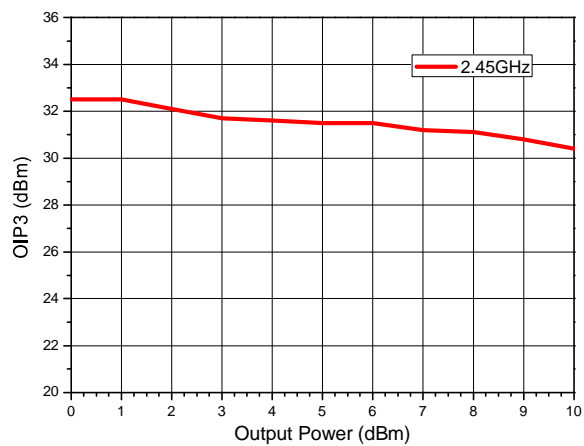
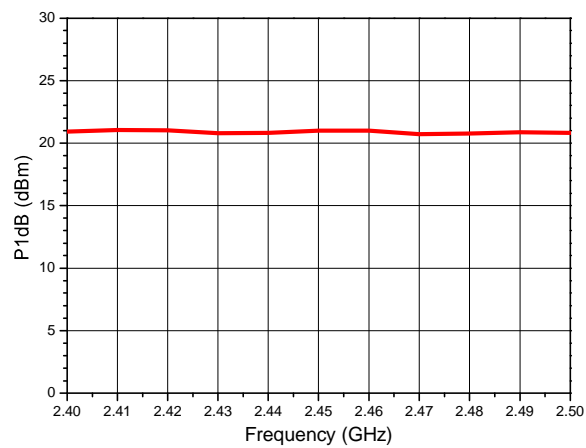
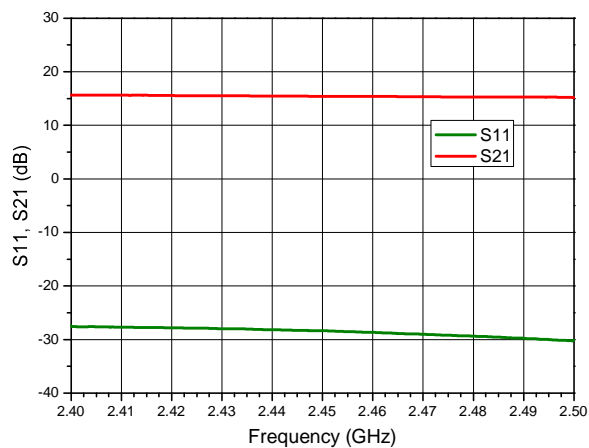
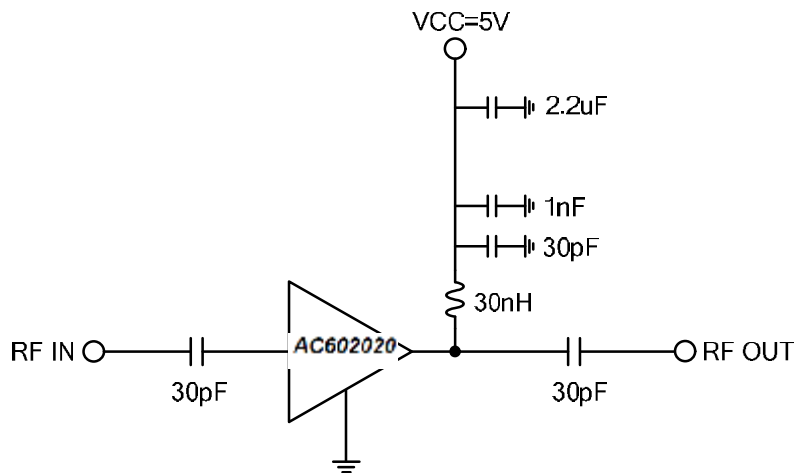



# AC602020 50MHz to 6GHz Gain Block MMIC Amplifier

## WCDMA (1900~2200MHz) Application:

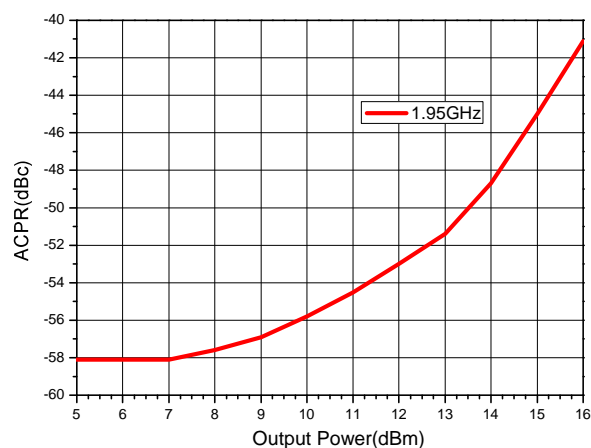
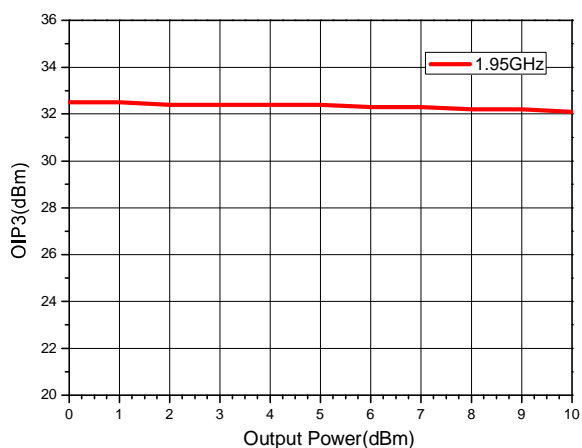
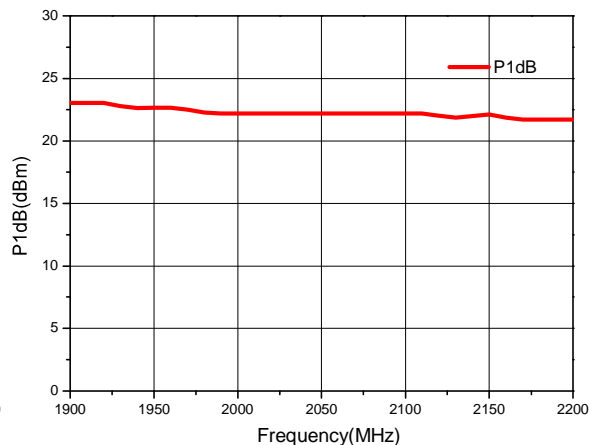
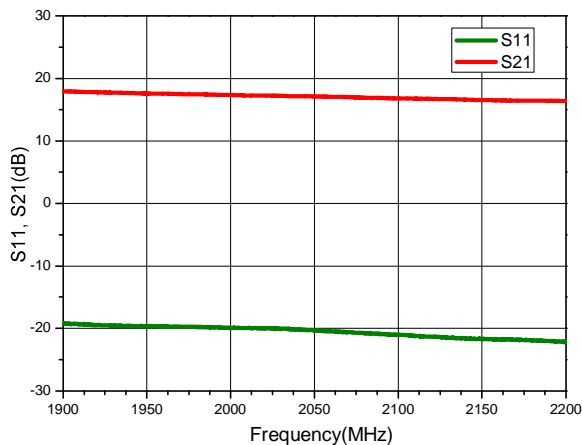
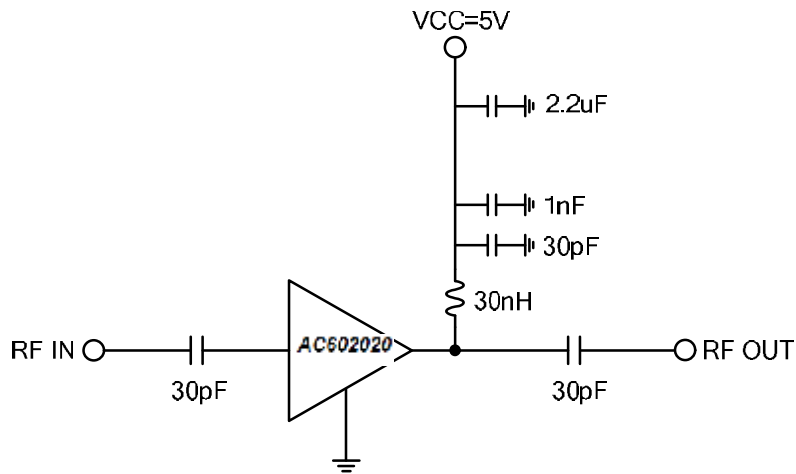

GPS/COMPASS Application:

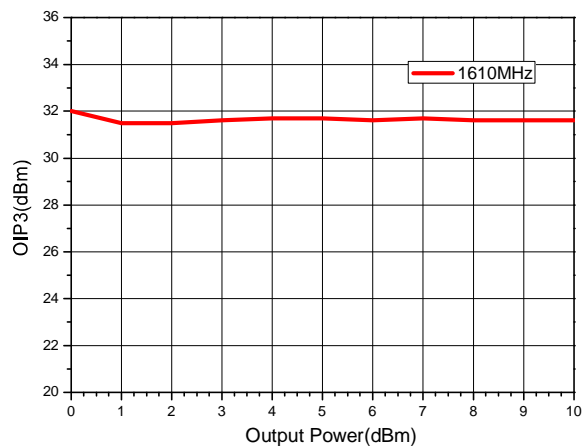
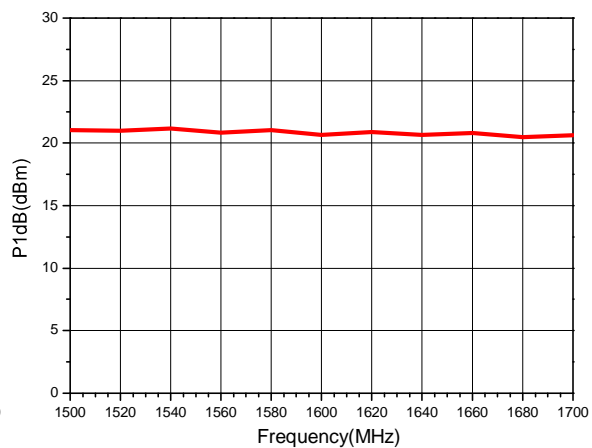
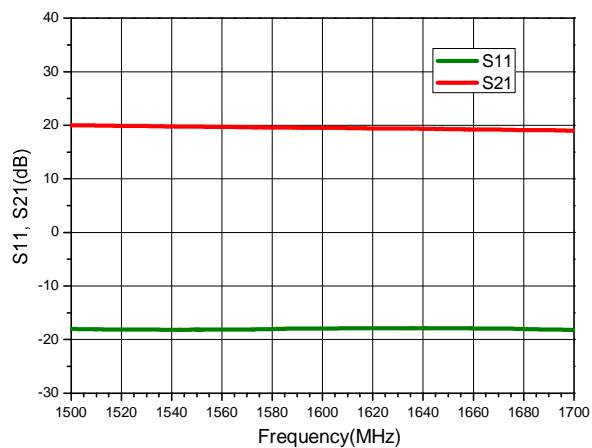
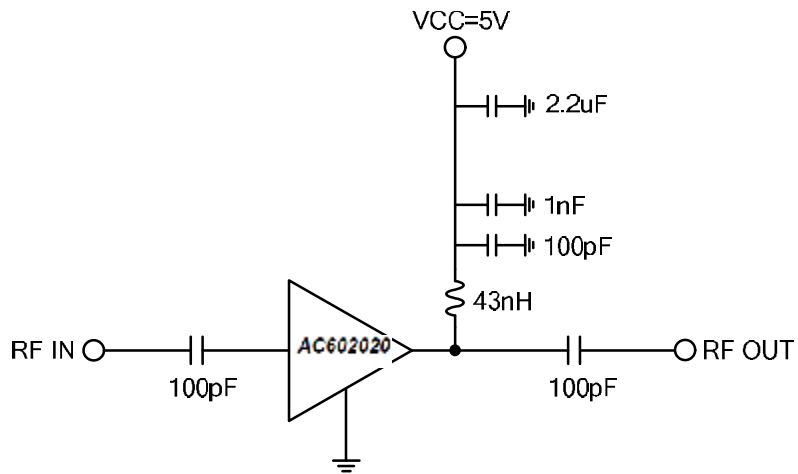

GSM (890~960MHz) Application:

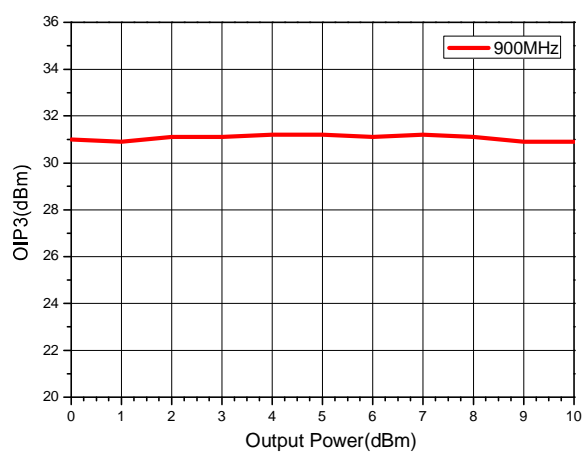
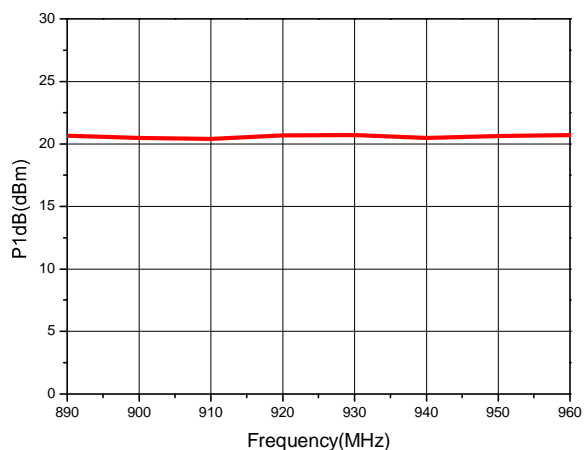
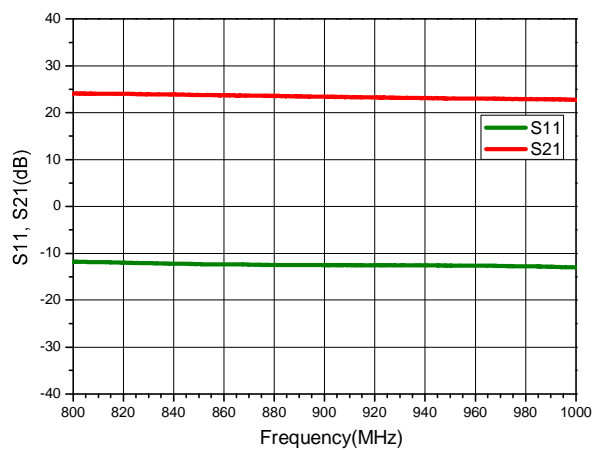
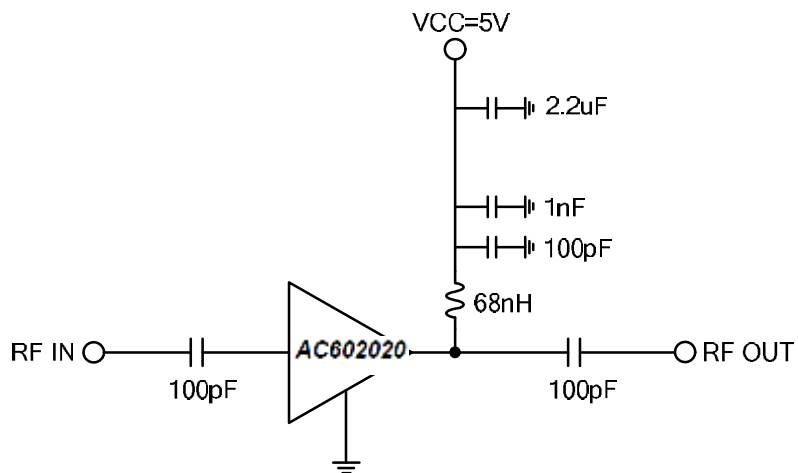

ISM (433MHz) Application Circuit:

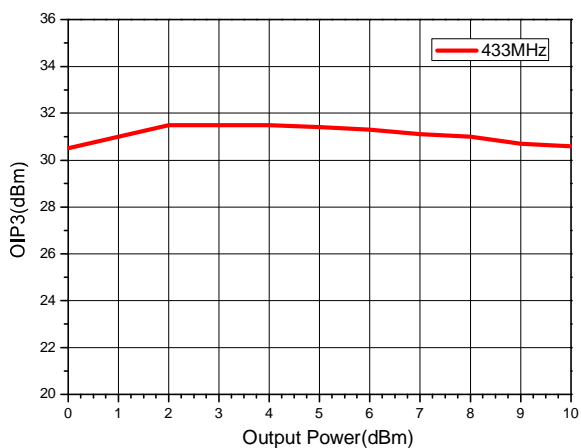
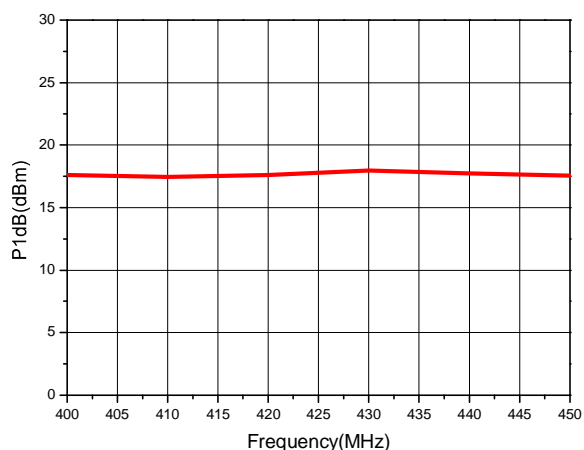
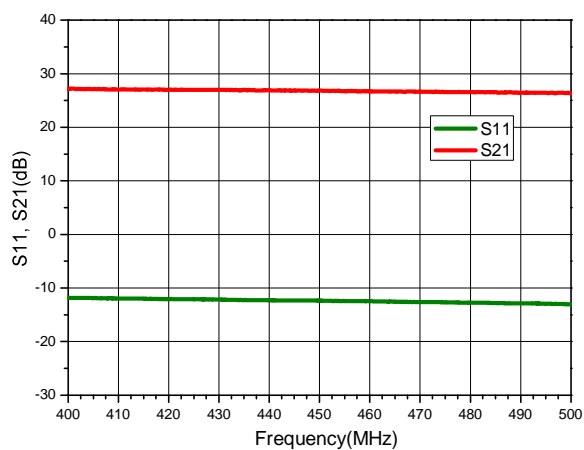
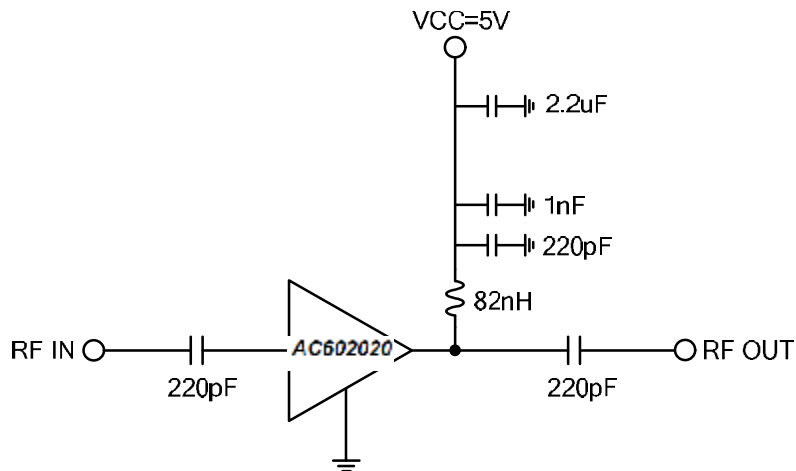

100~200 MHz Application Circuit:

