



# ACE500E

## Fast Transient Response LDO with Adjustable Output Voltage

### Description

ACE500E is a 500mA low noise and fast transient response linear regulator with adjustable output voltage and ultra low dropout voltage. Its output voltage is programmed by a resistor divider, and can be as low as 0.8V, which satisfies the most advanced ICs which may require supply voltage to be 0.9V – 1.2V.

ACE500E consists of a precise voltage reference, an error amplifier, a compensation network and a low ON-resistance power P-MOSFET. It also integrates many protection circuitry, like current limit and over-temperature protection module.

### Features

- 500mA output current
- Adjustable output voltage
- Minimum output voltage as low as 0.8V
- Ultra low dropout voltage 370mV @ 500mA
- Low quiescent current 40uA
- <1uA shutdown current
- Short-circuit protection
- Over-temperature protection
- Accuracy  $\pm 1\%$  ;  $\pm 2\%$

### Applications

- Cellphones
- Camera modules
- Medical Instruments
- Battery powered devices

### Absolute Maximum Ratings

Parameter	Symbol
VIN Voltage	-0.3V~8V
All Other Pin Voltage	VIN-0.3V~VIN0.3
VIN to GND Current	Internally limited
Operating Temperature Range	-40~85°C
Storage Temperature Range	-55°C~150°C
Thermal Resistance	$\theta_{JA}$ 190 °C/W



# ACE500E

## Fast Transient Response LDO with Adjustable Output Voltage

### TYPICAL APPLICATION

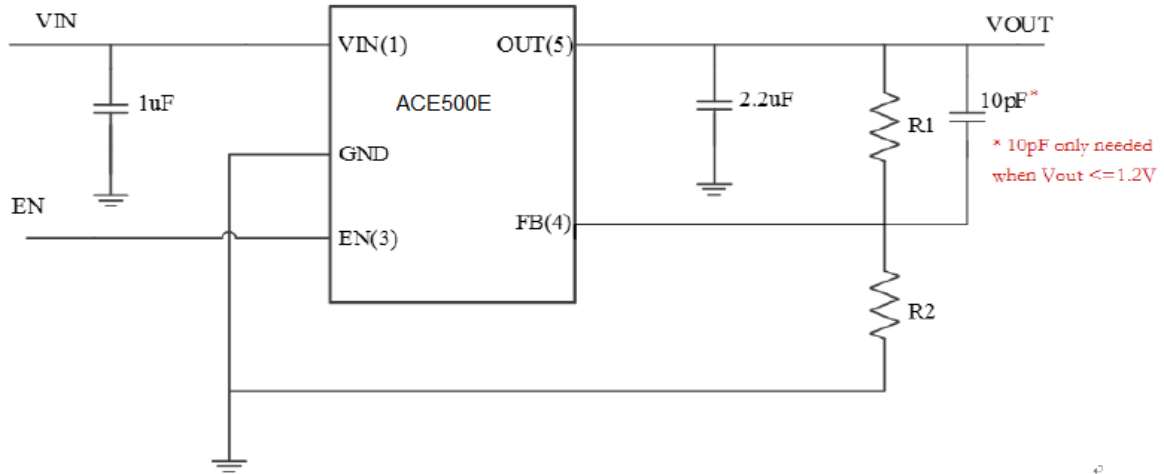

### Packaging Type

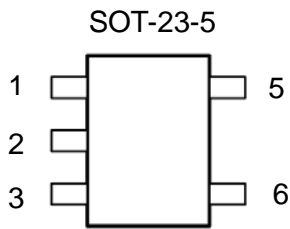

Pin #	Name	Description
1	VIN	Input voltage pin, connect a 1uF capacitor to GND
2	GND	Ground
3	EN	Enable pin. Pull this pin "high" to turn on the chip and "low" to turn off
4	FB	Feedback pin. Feedback voltage is set to be 0.8V. Output voltage is programmed by a resistor divider from Vout thru FB to GND, and by the equation $0.8V \times R1+R2/ R2= Vout$
5	VOUT	Output voltage pin, connect a 2.2uF capacitor to GND

### Ordering information

ACE500E X XX + H

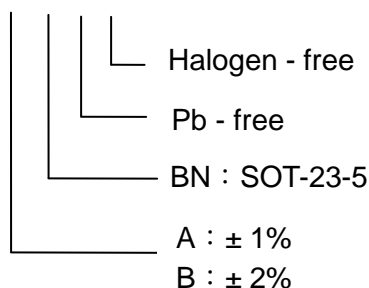



# ACE500E

## Fast Transient Response LDO with Adjustable Output Voltage

### Electrical Characteristics

( $V_{IN} = 5V$ , unless otherwise specified. Typical values are at  $T_A = 25^\circ C$ .)

Parameter	Conditions	Min	Typ	Max	Units
INPUT Range		2.5		6.0	V
Quiescent Current ( $I_q$ )	$V_{fb}=1V$		40		$\mu A$
Feedback Voltage ( $V_{fb}$ )		0.775	0.8	0.825	mV
Dropout Voltage ( $V_{drop}$ )	$I_{out}=100mA$		75		mV
	$I_{out}=300mA$		225		
	$I_{out}=500mA$		370		
Line Regulation	$2.5V < V_{in} < 5.5$		0.075		%/V
Load Regulation	$0mA < I_{out} < 500mA$		0.6		%/A
Maximum Output Current ( $I_{out\_Max}$ )	$V_{in} - V_{out} = 1V$		0.9	1.05	A
Current Limit			1.05		A
EN logic "high" Voltage	Voltage to turn on the chip	1.5			V
EN logic "low" Voltage	Voltage to turn off the chip			0.5	V
Thermal Protection			150		$^\circ C$
Ripple Rejection	$F=100Hz$ , Ripple=0.5Vp-p $V_{IN} = \text{Set } V_{OUT} + 1V$		65		dB

### Typical Performance Characteristics

(Typical values are at  $T_A = 25^\circ C$  unless otherwise specified.)

Dropout Voltage  $V_{in}=5V$

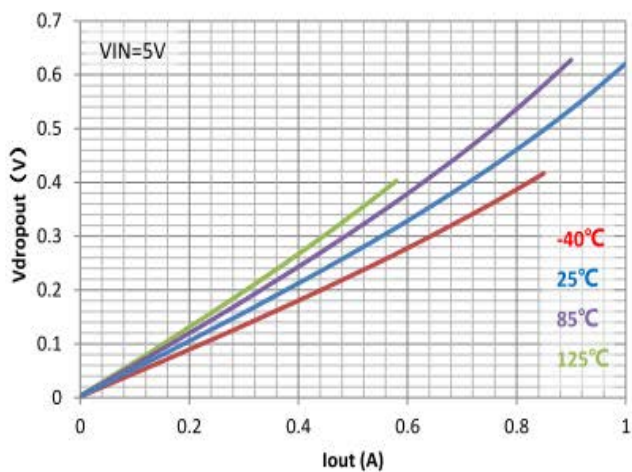

Dropout Voltage  $V_{in}=3.5V$

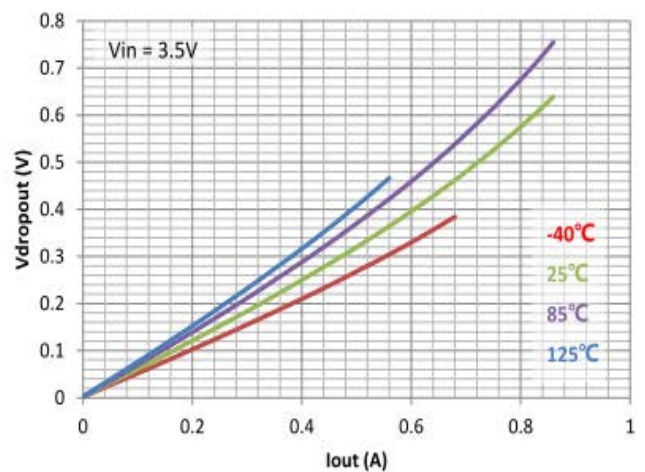



# ACE500E

## Fast Transient Response LDO with Adjustable Output Voltage

### Typical Performance Characteristics

(Typical values are at TA = 25°C unless otherwise specified.)

Dropout Voltage Vin=2V

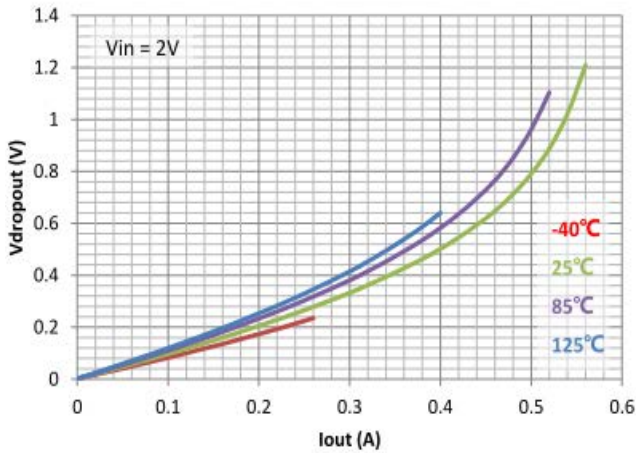

Quiescent current Vout=3.3V

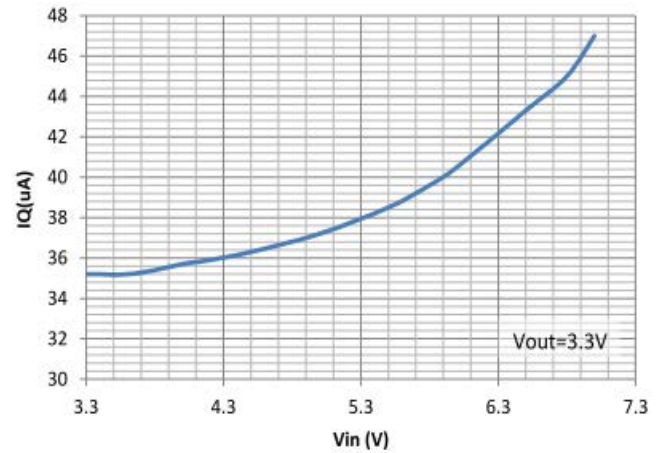

Line Regulation Vout=3.3V

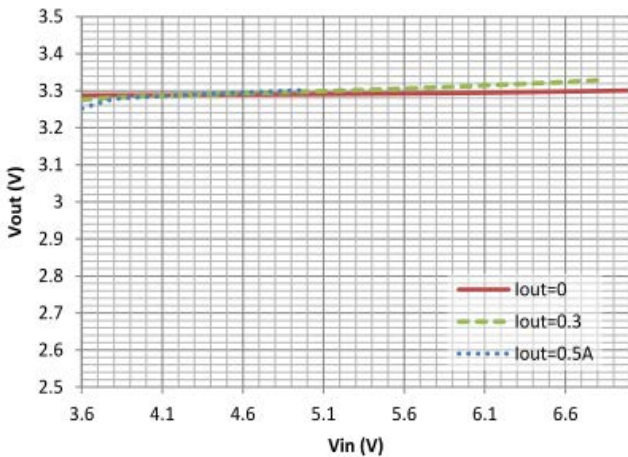

Load Regulation Vout=3.3V

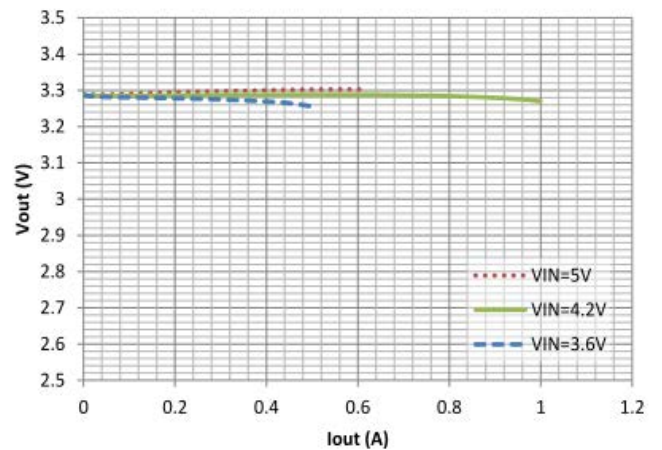

Line Regulation Vout=0.8V

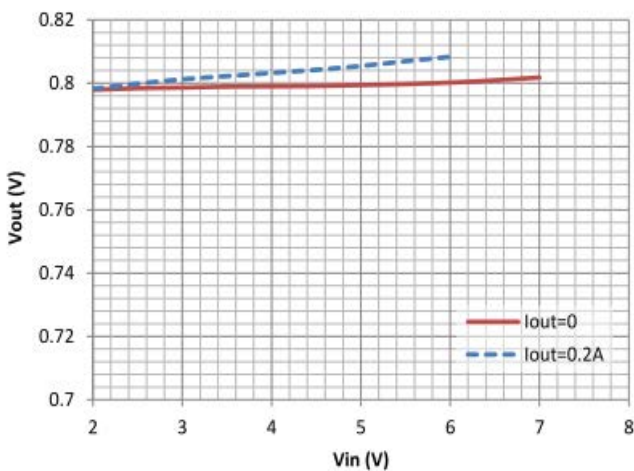

Load Regulation Vout=0.8V

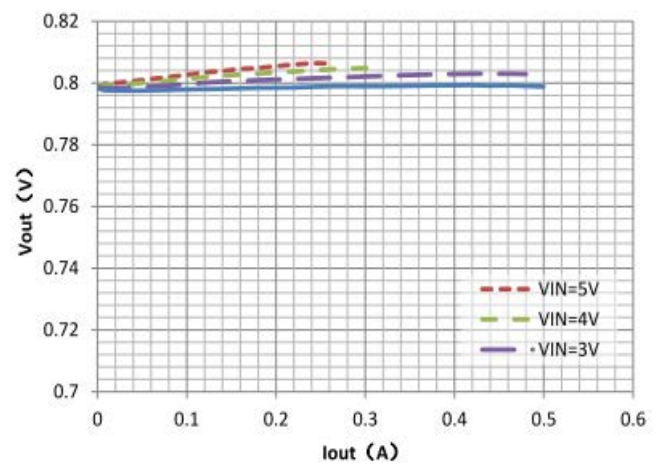



# ACE500E

## Fast Transient Response LDO with Adjustable Output Voltage

Load Transient Response at  $I_{out} = 500\text{mA}$ ,  $V_{out} = 3.3\text{V}$

Startup Waveform at  $I_{out} = 200\text{mA}$ ,  $V_{out} = 3.3\text{V}$

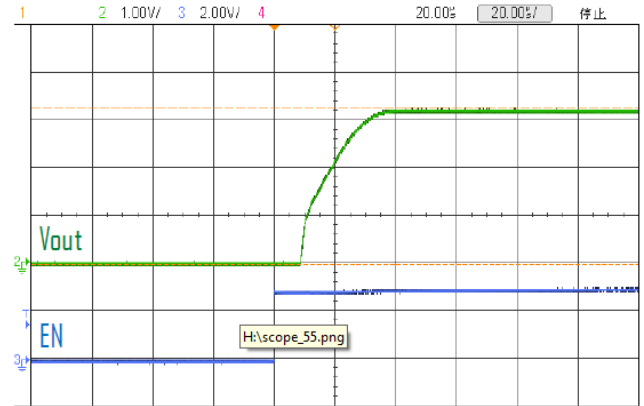
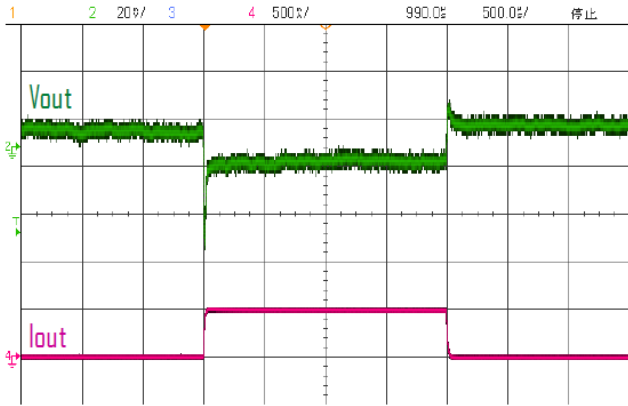



# ACE500E

## Fast Transient Response LDO with Adjustable Output Voltage

### Packing Information

#### SOT-23-5

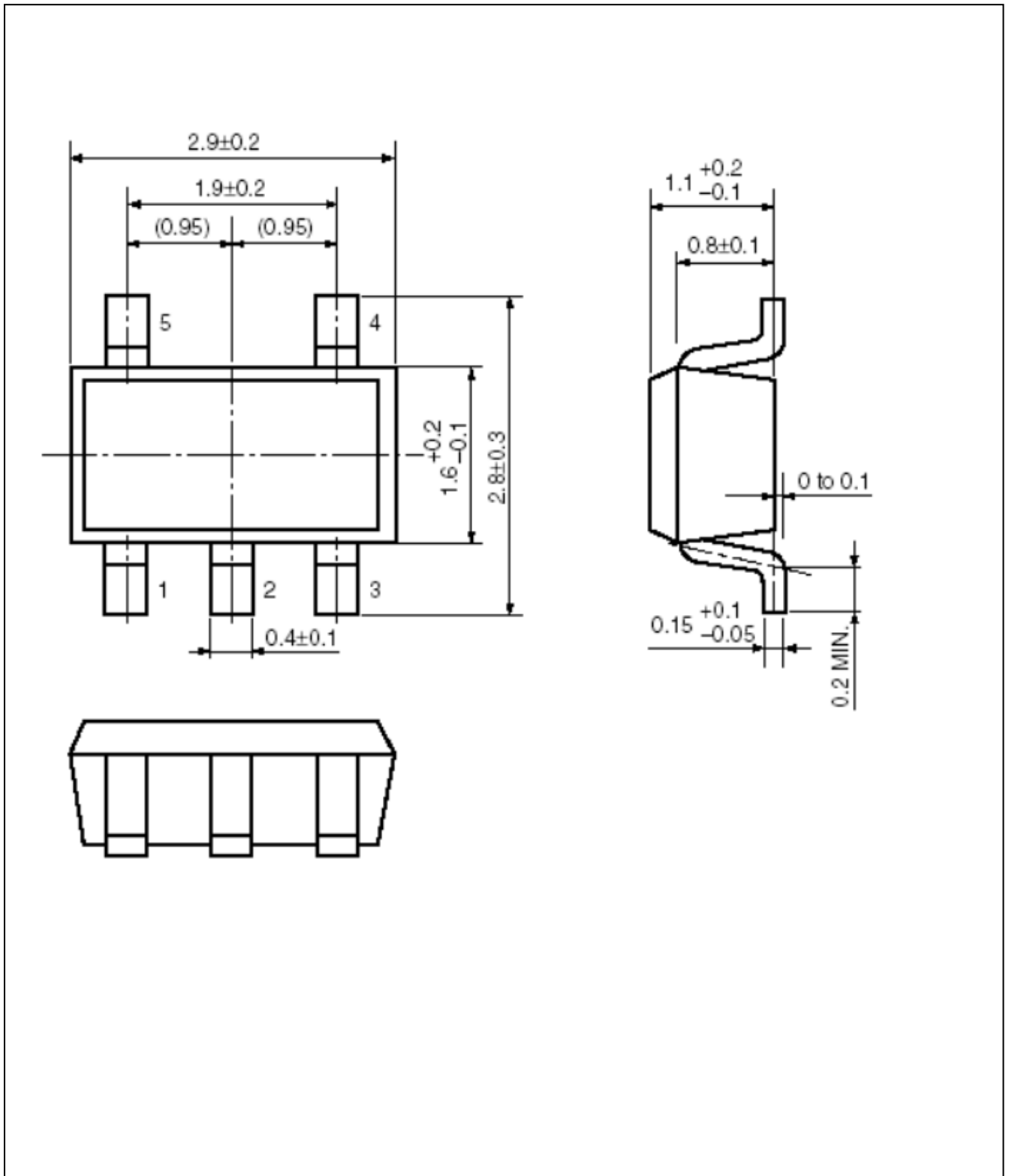



# ACE500E

## Fast Transient Response LDO with Adjustable Output Voltage

### Notes

ACE does not assume any responsibility for use as critical components in life support devices or systems without the express written approval of the president and general counsel of ACE Electronics Co., LTD. As sued herein:

1. Life support devices or systems are devices or systems which, (a) are intended for surgical implant into the body, or (b) support or sustain life, and whose failure to perform when properly used in accordance with instructions for use provided in the labeling, can be reasonably expected to result in a significant injury to the user.
2. A critical component is any component of a life support device or system whose failure to perform can be reasonably expected to cause the failure of the life support device or system, or to affect its safety or effectiveness.

ACE Technology Co., LTD.

<http://www.ace-ele.com/>