

Description

The ACE510 dual, low-noise, low-dropout regulator delivers at least 150mA of continuous output current. The output voltage for each regulator is set independently by trimming. Voltages are selectable in 100mV steps within a range of 1.2V to 5.0V. Typical output noise is 27 μ V_{rms}, and PSRR is 65dB at 1KHz. The ACE510 includes two independent logic-controlled shutdown inputs and allows the output of each regulator to be turned off independently.

The ACE510 includes high accuracy voltage reference, error amplifier, current limit circuit and output driver module.

The ACE510 has excellent load and line transient response and good temperature characteristics, which can assure the stability of chip and power system. And it uses trimming technique to guarantee output voltage accuracy within $\pm 2\%$. The ACE510 is available in SOT-23-6 package which is lead (Pb)- free

Features

- Two low dropout voltage regulators
- 150mA output current for each LDO
- 25 μ A operating supply current per LDO
- Low 27 μ V_{RMS} output noise V~10V
- Standby Mode: 0.1 μ A
- Low 200mV dropout at 100mA load
- 65dB PSRR at kHz
- Excellent Line regulation: 0.05%/V
- Independent Shutdown controls
- 1.2V to 5.0V Factory-Preset Output
- Output Current Limit
- Highly Accurate: $\pm 2\%$ ($\pm 1\%$ customized)

Application

- Cellular phones
- Cordless phones and radio communication equipment
- Battery Powered equipment
- Notebook and hand-ole equipment
- Wireless LAN
- GPS receivers

Typical Performance Characteristic:

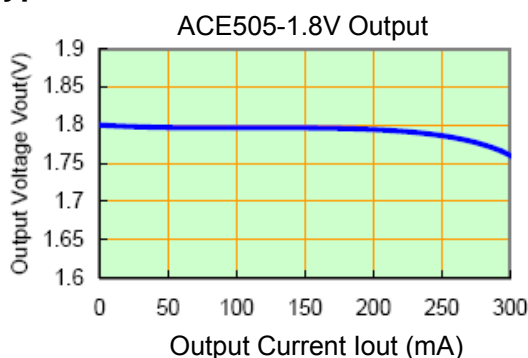

Absolute Maximum Ratings

Parameter	Symbol	Max	Unit
Input voltage	V_{IN}	10	V
Power Dissipation SOT-23-6		200	mW
Junction temperature	T_J	125	°C
Storage temperature	T_S	- 45 to 150	°C
Output Current		200	mA

Packaging Type

SOT-23-6

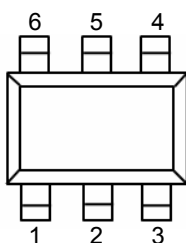

Pin	SOT-23-6(C)	SOT-23-6(D)	SOT-23-6(E)	Function
V_{out1}	1	6	6	Output 1 pin
V_{dd}	2	2	5	Input pin
V_{out2}	3	4	1	Output 2 pin
CE2	4	3	3	Chip Enable pin2
GND	5	5	2	Ground pin
CE1	6	1	4	Chip Enable pin1

Ordering information

Selection Guide

ACE510 XX XX + H

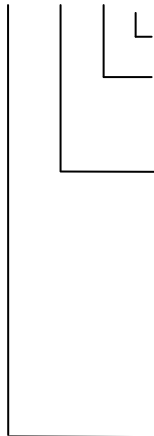

Halogen - free

Pb - free

CGM : SPT-23-6C

DGM : SOT-23-6D

EGM : SOT-23-6E

Output Voltage :

A:1.5V(Output1),2.5V(Output2)

C:1.5V(Output1),3.0V(Output2)

E:1.5V(Output1),4.0V(Output2)

G:1.8V(Output1),2.5V(Output2)

I: 1.8V(Output1),3.0V(Output2)

K: 2.5V(Output1),1.8V(Output2)

M:2.8V(Output1),1.8V(Output2)

O:2.8V(Output1),2.8V(Output2)

Q:3.0V(Output1),2.5V(Output2)

S:3.0V(Output1),3.3V(Output2)

U:3.3V(Output1),2.5V(Output2)

W:5.0V(Output1),3.3V(Output2)

Y:2.8V(Output1),3.3V(Output2)

B:1.5V(Output1),2.8V(Output2)

D:1.5V(Output1),3.3V(Output2)

F:1.8V(Output1),1.8V(Output2)

H:1.8V(Output1),2.8V(Output2)

J:1.8V(Output1),3.3V(Output2)

L:2.5V(Output1),2.5V(Output2)

N:2.8V(Output1),2.5V(Output2)

P:2.8V(Output1),3.0V(Output2)

R:3.0V(Output1),3.0V(Output2)

T:3.3V(Output1),1.8V(Output2)

V:3.3V(Output1),2.8V(Output2)

X:2.8V(Output1),1.5V(Output2)

Z:3.3V(Output1),3.3V(Output2)

Block Diagram

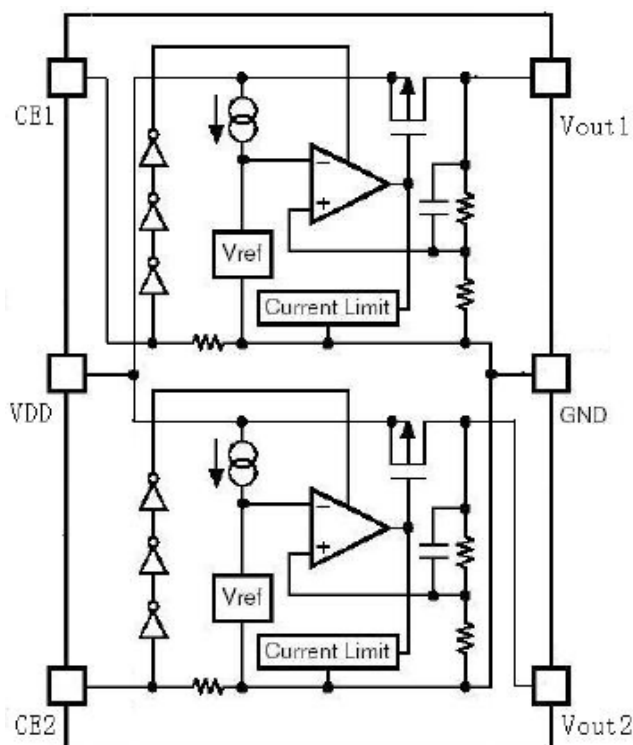

Recommended Work Conditions

Item	Min	Recommended	Max	Unit
Input Voltage Range			8	V
Ambient Temperature	-40		85	°C

Electrical Characteristics

(Test Conditions: C1=1uF, C2=C3=2.2uF, TA=25°C, unless otherwise specified.)

ACE510, fro arbitrary output voltage

Parameter	Symbol	Conditions	Min	Typ	Max	Units
Input Voltage	V_{IN}		1.8		8	V
Output Voltage	V_{OUT}	$V_{in} = \text{Set } V_{out} + 1V$ $1mA \leq I_{out} \leq 30mA$	$V_{out} \times 0.98$		$V_{out} \times 1.02$	V
Maximum Output Current	$I_{OUT(Max.)}$	$V_{in} - V_{out} = 1V$	150			mA
Input-Output Voltage Differential	Dropout Voltage	Refer to the Electrical Characteristics by Output Voltage				
Line Regulation	$\frac{\Delta V_{OUT}}{\Delta V_{IN}} \cdot V_{OUT}$	$I_{out} = 40mA$ $1.6V \leq V_{in} \leq 8V$		0.05	0.2	%/V
Load Regulation	$\Delta V_{OUT} / \Delta I_{OUT}$	$V_{in} = \text{Set } V_{out} + 1V$ $1mA \leq I_{out} \leq 80mA$		12	40	mA
Supply Current	I_{SS}	$V_{in} = \text{Set } V_{out} + 1V$		25	50	uA
Supply Current (Srandby)	$I_{standby}$	$V_{in} = \text{Set } V_{out} + 1V$		0.2	1.0	uA

		Vce=Gnd				
Output Voltage Temperature Coefficiency	$\frac{\Delta V_{OUT}}{\Delta T \cdot V_{OUT}}$	Iout=30mA		±100		ppm/°C
Ripple Rejection	PSRR	F=1kHz Ripple=0.5Vp-p Vin=Set Vout+1V		65		dB
Short Current Limit	Llim	Vout=0V		20		mA
CE Pull down Resistance	Rpd		2.0	5.0	10.0	MΩ
CE Input Voltage "H"	Vceh		1.5		Vin	V
CE Input Voltage "L"	Vcel		0		0.25	V
Output Noise	en	BW=10Hz~100kHz		27		uVrms

Electrical Characteristics by Output Voltage

Output Voltage Vout(V)	Dropout Voltage, V _{DIF} (V)		
	Condition	Typ	Max
Vout=1.5V	Iout=120mA	0.38	0.70
Vout=1.6V		0.36	0.65
Vout=1.7V		0.34	0.60
1.8 ≤ Vout ≤ 2.0		0.32	0.55
2.1 ≤ Vout ≤ 2.7		0.28	0.50
2.8 ≤ Vout ≤ 4.0		0.22	0.35

Typical Application Circuit

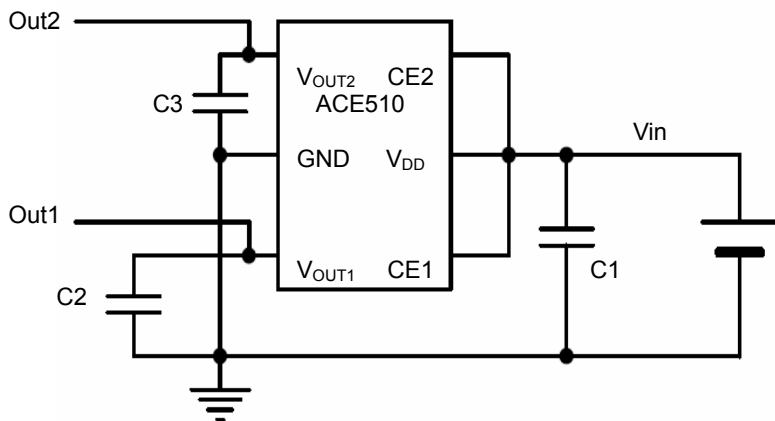

Application hints:

Note 1: Input capacitor (Cin=1uF) is recommended in all application circuit.

Note 2: Output capacitor (C2=C3=1uF/2.2uF) is recommended in all application to assure the stability of circuit.

Explanation :

The ACE510 series are highly accurate ,Dual, low noise, CMOS low dropout voltage regulators.

The output voltage for each regulator is set independently by trimming. Voltages are selectable in 100mV steps within a range of 1.2V to 5.0V . It also can be customized on command.

The ACE510 includes high accuracy voltage reference, error amplifier, current limit circuit and output driver module.

The ACE510 has excellent load and line transient response and good temperature characteristics, which can assure the stability of chip and power system. And it uses trimming technique to guarantee output voltage accuracy within±2%

Typical Performance Characteristics

1.Output Voltage vs. Output Current
(with output short protection)

ACE510-1.8V

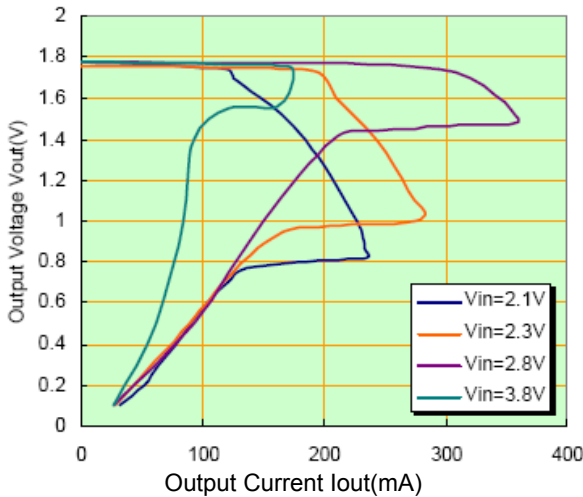

2.Output Voltage vs. Input Voltage

ACE510-1.8V

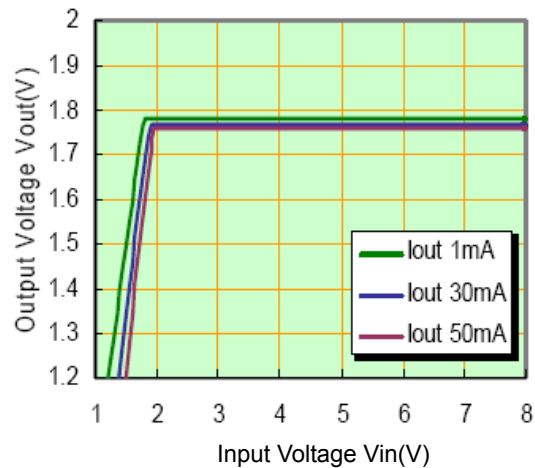

3.Dropout Voltage vs. Output Current

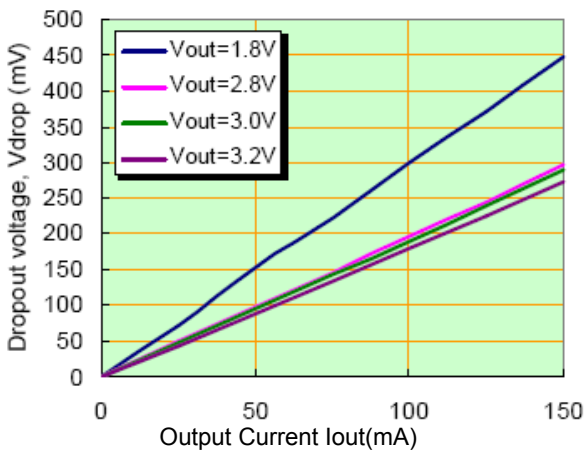

4.Supply Current vs. Input Voltage

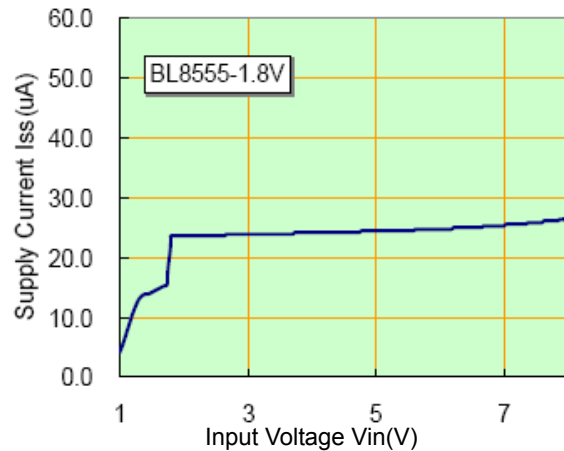

5. Ripple rejection vs. Frequency

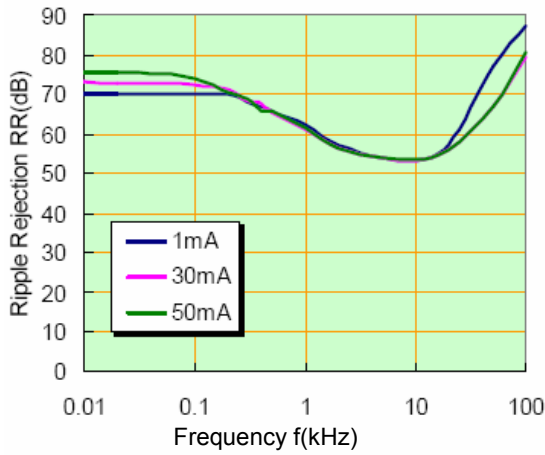

6. Line transient response Voltage

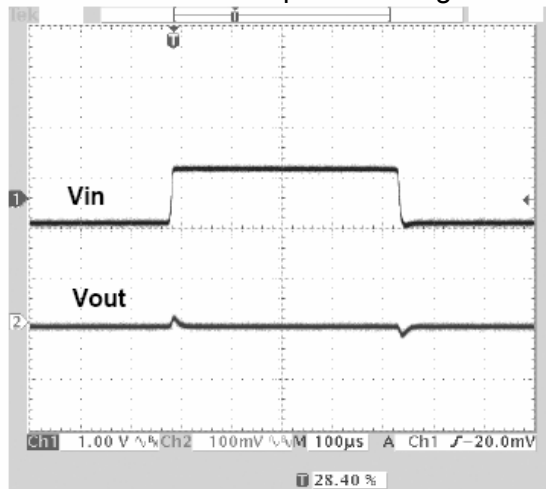

7. Load transient response

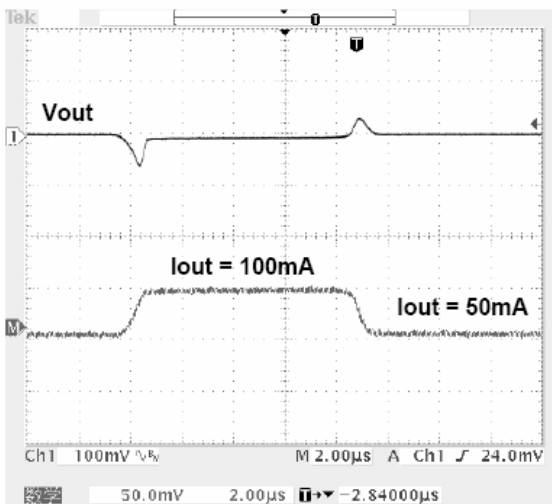

Packing Information

SOT-23-6

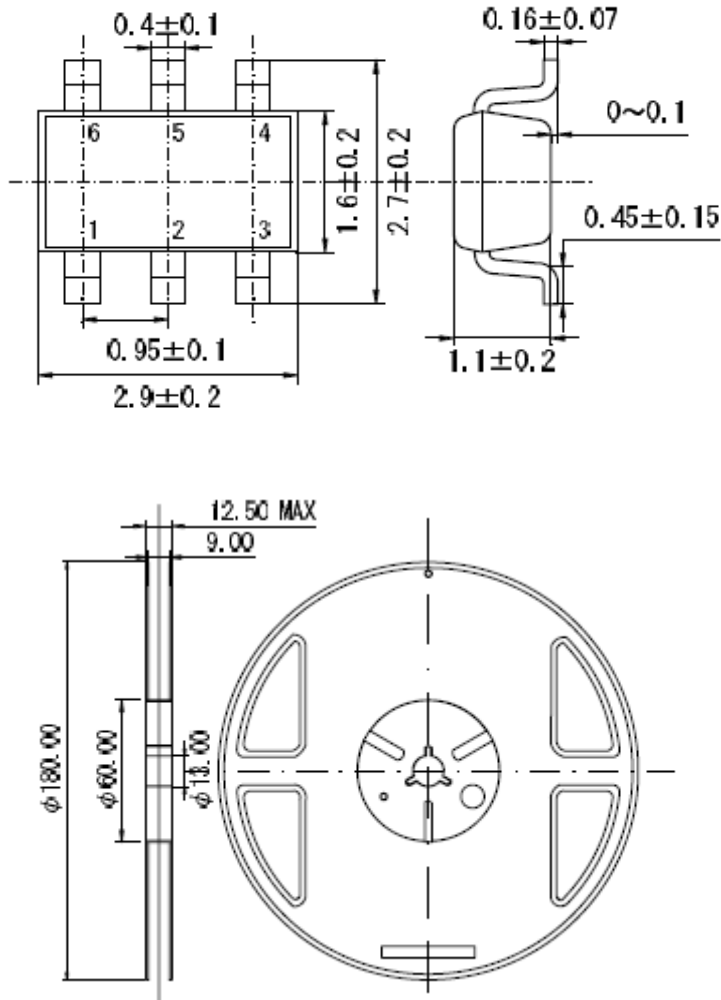

Notes

ACE does not assume any responsibility for use as critical components in life support devices or systems without the express written approval of the president and general counsel of ACE Electronics Co., LTD.

As sued herein:

1. Life support devices or systems are devices or systems which, (a) are intended for surgical implant into the body, or (b) support or sustain life, and whose failure to perform when properly used in accordance with instructions for use provided in the labeling, can be reasonably expected to result in a significant injury to the user.
2. A critical component is any component of a life support device or system whose failure to perform can be reasonably expected to cause the failure of the life support device or system, or to affect its safety or effectiveness.

ACE Technology Co., LTD.

<http://www.ace-ele.com/>