



# ACE705

## High efficiency, Low supply current, step-up DC/DC Controller

### Description

The ACE705 series are CMOS-based PFM step-up DC-DC Controller with low supply current and high output voltage accuracy. Quiescent current drawn from power source is as low as 6 $\mu$ A. It is capable of delivering 500mA output current at 4.0V output with 2V input Voltage. Only four external components are necessary: An inductor, a Schottky diode, an output filter capacitor and a NMOSFET or a NPN transistor. All of these features make ACE705 series be suitable for the portable devices, which are supplied by a single battery to four-cell batteries.

ACE705 has a drive pin (EXT) for external transistor. So it is possible to load a large output current with a power transistor which has a low saturation voltage.

ACE705 integrates stable reference circuits and trimming technology, so it can afford high precision and low temperature-drift coefficient of the output voltage.

ACE705 is available in SOT-23-3 and SOT-23-5 packages which are PB free. And in SOT-23-5 the device can be switch on or off easily by CE pin, to minimize the standby supply current.

### Features

- Deliver 500mA at 4.0V Output voltage with 2.0V input Voltage
- The converter output voltage can be adjusted from 2.5V~6.0V(In 0.1V step)
- Output voltage accuracy  $\pm 2\%$
- Low temperature-drift coefficient of the output voltage  $\pm 100\text{ppm}/^\circ\text{C}$
- Only four external components are necessary: An inductor, a Schottky diode an output filter capacitor and a NMOSFET or a NPN transistor
- High power conversion efficiency 90%
- Low quiescent current drawn from power source 6 $\mu$ A

### Application

- Power source for PDA. DSC. MP3 Player. electronic toy and wireless mouse
- Power source for a single or dual-cell battery-powered equipments
- Power source for LED

### Absolute Maximum Ratings

Parameter	Symbol	Max	Unit
Input voltage range		-0.3~12	V
Input voltage	V(EXT)	-0.3~Vout+0.3	V
CE pin voltage		-0.3~Vout+0.3	V
EXT pin output current		0.7	A
Maximum power dissipation, Pd T=25 $^\circ\text{C}$			
SOT-23-5		250	mW
SOT-23-3		250	
Operating junction temperature		125	$^\circ\text{C}$
Ambient Temperature		-40~85	$^\circ\text{C}$
Storage temperature range		-40~150	$^\circ\text{C}$



# ACE705

High efficiency, Low supply current, step-up DC/DC Controller

## Packaging Type

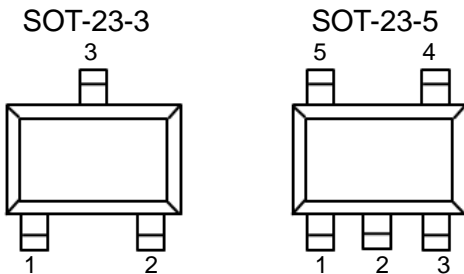

SOT-23-3	SOT-23-5	Description	Function
1	4	V <sub>SS</sub> (GND)	Ground pin
2	2	V <sub>OUT</sub>	Output pin, power supply for internal circuits
3	5	Ext	Switching pin
	3	NC	No connection
	1	CE	Chip enable pin (active high)

## Ordering information

ACE705 X XX XX + H

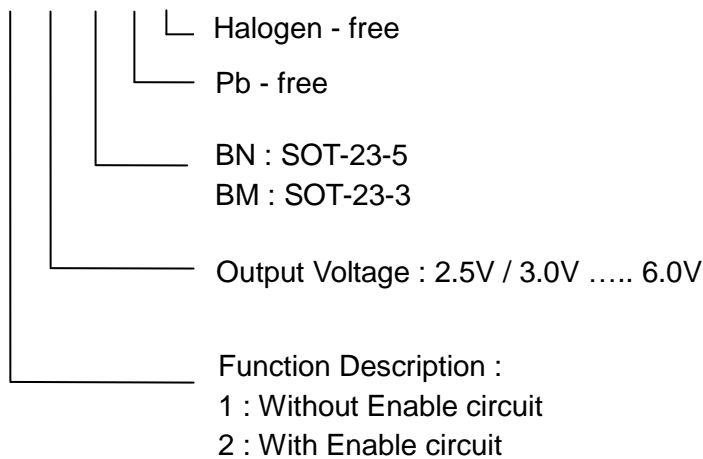



# ACE705

High efficiency, Low supply current, step-up DC/DC Controller

## Block Diagram

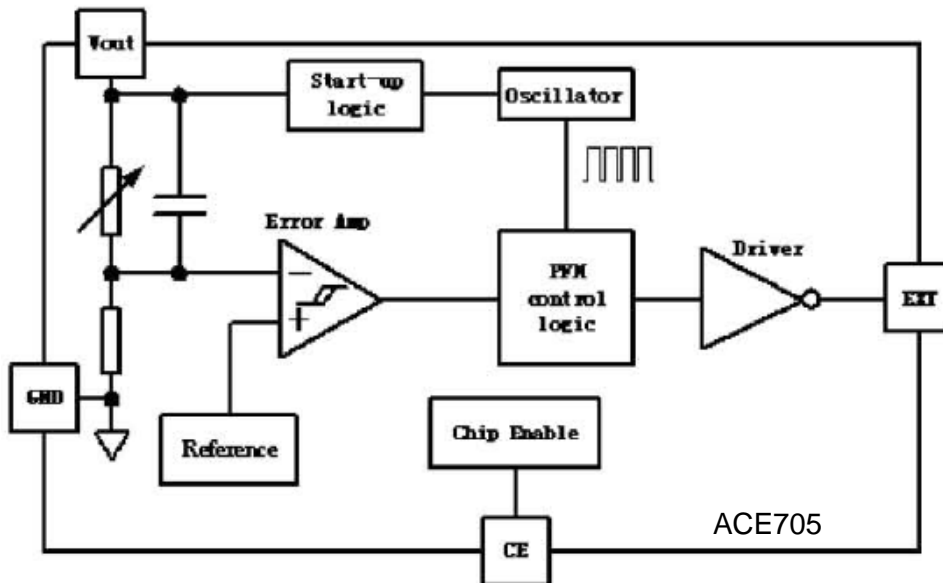

## Recommended Work Conditions

Item	Min	Nom	Max	Unit
Input voltage range	0.8		Vout	V
Inductor	10		100	$\mu$ H
Input capacitor	0	$\geq 10$		$\mu$ F
Output capacitor	47		220	$\mu$ F
Ambient Temperature ( $T_A$ )	-40		85	$^{\circ}$ C

\*Suggestion: Use tantalum type capacitor to reduce the ripple of the output voltage. Use 1nF filter ceramic type capacitor to connect Vout pin and GND pin. The filter capacitor is recommended as close as possible to Vout pin and GND pin.



# ACE705

## High efficiency, Low supply current, step-up DC/DC Controller

### Electrical Characteristics

Default condition (unless otherwise provided):  $V_{in}=0.6 \times V_{out}$ ,  $I_{out}=10\text{mA}$ . Temperature= $25^{\circ}\text{C}$ . Use external circuit in test circuit list.

Parameter	Symbol	Test Conditions	Min	Typ	Max	Unit
Output Voltage	Vout		2.45	2.5	2.55	V
			2.646	2.7	2.754	
			2.94	3.0	3.06	
			3.234	3.3	3.366	
			3.528	3.6	3.672	
			3.92	4.0	4.08	
			4.9	5.0	5.1	
			5.88	6.0	6.12	
Input Voltage	Vin				12	V
Input Current * (no load)	Lin	$I_{out}=0\text{mA}$ , $V_{in}=V_{out} \times 0.6$		20	25	uA
Quiescent current *	I <sub>DD</sub>	No external component, $V_{out}=V_{out} \times 1.05$		6	15	uA
Chip leakage current	I <sub>standby</sub>	$V_{CE}=0\text{V}$			1	uA
CE "H" threshold voltage	V <sub>CEH</sub>	$V_{CE}:0 \rightarrow 2\text{V}$	0.8			V
CE "L" threshold voltage	V <sub>CEL</sub>	$V_{CE}:2 \rightarrow 0\text{V}$			0.3	V
Oscillator frequency	F <sub>OSC</sub>	$V_{out}=V_{out} \times 0.96$ Test EXT pin frequency		350		Khz
CE "H"	I <sub>CEH</sub>	$V_{out}=V_{CE}=6\text{V}$	-0.5	0	0.5	uA
CE "L"	I <sub>CEL</sub>	$V_{out}=V_{CE}=6\text{V}$	-0.5	0	0.5	uA
EXT "H" output current	I <sub>EXTH</sub>	$3.0\text{V} \leq V_{out} \leq 3.9\text{V}$		-21		mA
		$4.0\text{V} \leq V_{out} \leq 4.9\text{V}$		-35		
		$5.0\text{V} \leq V_{out} \leq 6.9\text{V}$		-41		
EXT "H" output current	I <sub>EXTL</sub>	$3.0\text{V} \leq V_{out} \leq 3.9\text{V}$		23		mA
		$4.0\text{V} \leq V_{out} \leq 4.9\text{V}$		25		
		$5.0\text{V} \leq V_{out} \leq 6.9\text{V}$		31		
Oscillator duty cycle	Duty	On(V <sub>Ix</sub> "L") side	70	75	80	%

Note :

1. Diode: Schottky type, such as: 1N5817, 1N5819, 1N5822
2. Inductor: 27uH(R<0.5Ω)
3. Output Capacitor: 100uF (Tantalum type)
4. Vout pin filter capacitor: 1nF (Ceramic type)
5. Input capacitor: 47uF



### Typical Application

#### (1) Application with external NMOSFET

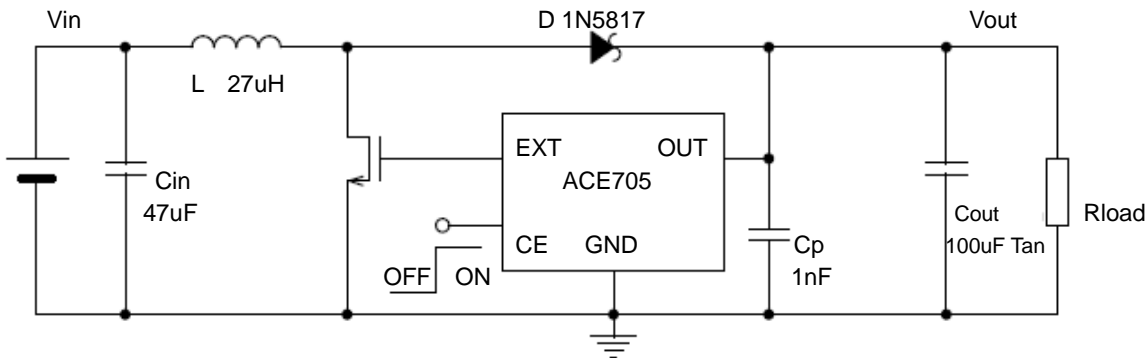

Figure 1

#### (2) Application with external NPN transistor

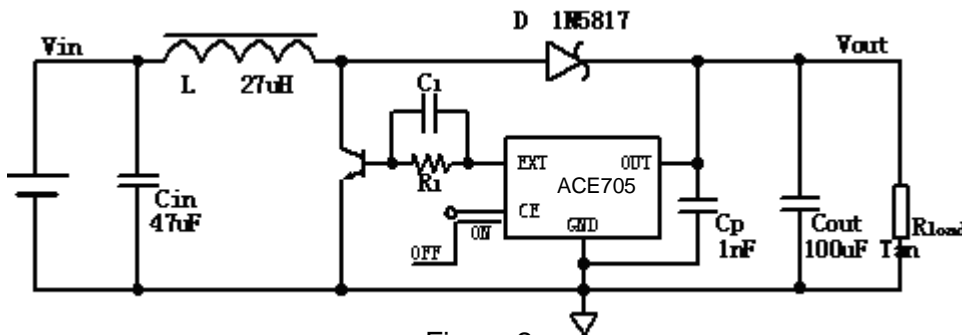

Figure 2

Note:  $R_1=330\Omega$ ,  $C_1=10nF$ . ( $R_1$  can be calculated by load. If load is light  $R_1$ 's value can be added. If load is heavy  $R_1$ 's value can be smaller. )

### Detailed Description

The ACE705 series are boost structure, voltage-type pulse-frequency modulation(PFM) step-up DC-DC controller. Only four external components are necessary: an inductor, a schottky diode, an output filter capacitor and a NMOSFET or a NPN transistor. The step-up DC-DC converter, constructed by ACE705, can be adjusted from 2.5V to 6.0V, 0.1V step. By using the depletion technics, the quiescent current drawn from power source is lower than 8uA. The high efficiency device consists of resistors for output voltage detection and trimming, a start-up voltage circuit, an oscillator, a reference circuit, a PFM control circuit, a switch protection circuit and a driver transistor.

ACE705 integrates PFM control system. This system controls fixed power switch on duty cycle frequency to stabilize output voltage by calculating results of other blocks which sense input voltage, output voltage, output current and load conditions. In PFM modulation system, the frequency and pulse width is fixed. The duty cycle is adjusted by skipping pulses, so that switch on-time is changed based on the conditions such as input voltage, output current and load. The oscillate block inside ACE705 provides fixed frequency and pulse width wave.



The reference circuit provides stable reference voltage to output stable output voltage. Because internal trimming technology is used, the chip output change less than  $\pm 2\%$ . At the same time, the problem of temperature-drift coefficient of output voltage is considered in design, so temperature-drift coefficient of output voltage is less than  $100\text{ppm}/^\circ\text{C}$ .

High-gain differential error amplifier guarantees stable output voltage at difference input voltage and load. In order to reduce ripple and noise, the error amplifier is designed with high band-width.

ACE705 has a drive pin (EXT) for external transistor. So it is possible to load a large output current with a power transistor and a low saturation voltage. At very light load condition, the switch current and quiescent current of chip will effect efficiency certainly. So in very light load condition, the efficiency will drop. Therefore, it is recommended that user use ACE705 in the condition of load current as large as several tens of mA to several hundreds of mA

### Selection of the External Components

Thus it can be seen, the inductor, schottky diode and external NMOSFET or NPN transistor. affect the conversion efficiency greatly. The inductor and the capacitor also have great influence on the output voltage ripple of the converter. So it is necessary to choose a suitable inductor, a capacitor, an external NMOSFET or NPN transistor and a right schottky diode, to obtain high efficiency and low ripple.

Before discussion, we define  $D \equiv V_{\text{out}} - V_{\text{in}} / V_{\text{out}}$

#### (1) Inductor Selection

Above all, we should define the minimum value of the inductor that can ensure the boost DC-DC to operate in the continuous current-mode condition.

$$L_{\text{min}} \geq D(1-D)^2 R_L / 2f$$

The above expression is got under conditions of continuous current mode, neglect Schottky diode's voltage, ESR of both inductor and capacitor. The actual value is greater than it. If inductor's value is less than  $L_{\text{min}}$ , the efficiency of DC-DC converter will drop greatly, and the DC-DC circuit will not be stable.

Secondly, consider the ripple of the output voltage,

$$\Delta I = D \cdot V_{\text{in}} / Lf$$

$$I_{\text{max}} = V_{\text{in}} / (1-D)^2 R_L + DV_{\text{in}} / 2Lf$$

If inductor value is too small, the current ripple through it will be great. Then the current through diode and power switch will be great. Because the power switch on chip is not ideal switch, the energy of switch will improve. The efficiency will fall.

Thirdly, in general, smaller inductor values supply more output current while larger values start up with lower input voltage and acquire high efficiency.



An inductor value of 3uH to 1mH works well in most applications. If DC-DC converter delivers large output current (for example: output current is great than 50mA), large inductor value is recommended in order to improve efficiency. If DC-DC must output very large current at low input supply voltage, small inductor value is recommended.

The ESR of inductor will effect efficiency greatly. Suppose ESR value of inductor is  $r_L$ ,  $R_{load}$  is load resistor, then the energy can be calculated by following expression:

$$\Delta\eta \approx R_L / R_{load} (1-D)^2$$

For example: input 1.5V, output is 3.0V,  $R_{load}=20\Omega$ ,  $r_L=0.5\Omega$ , The energy loss is 10%.

Consider all above, inductor value of 47uH, ESR<0.5Ω is recommended in most applications. Large value is recommended in high efficiency applications and smaller value is recommended

### (2)Output Capacitor Selection

Ignore ESR of capacitor, the ripple of output voltage is:

$$R = \Delta V_{out} / V_{out} = D / R_{load} C_f$$

So large value capacitor is needed to reduce ripple. But too large capacitor value will slow down system reaction and cost will improve. So 100uF capacitor is recommended. Larger capacitor value will be used in large output current system. If output current is small (<10mA), small value is needed.

Consider ESR of capacitor, ripple will increase :

$$r' = r + I_{max} \cdot R_{ESR} / V_{out}$$

When current is large, ripple caused by ESR will be main factor. It may be greater than 100mV. The ESR will affects efficiency and increase energy loss. So low-ESR capacitor (for example: tantalum capacitor) is recommend or connect two or more filter capacitors in parallel.

### (3)Diode Selection

Rectifier diode will affects efficiency greatly, Though a common diode (such as 1N4148) will work well for light load, it will reduce about 5%~10% efficiency for heavy load, For optimum performance, a Schottky diode (such as 1N5817, 1N5819, 1N5822) is recommended.

### (4)Input Capacitor

If supply voltage is stable, the DC-DC circuit can output low ripple, low noise and stable voltage without input capacitor. If voltage source is far away from DC-DC circuit, input capacitor value greater than 10uF is recommended.



### (5) Vout~GND filter Capacitor

Because the chip's switch current flows from Vout pin, then through the chip into GND pin. Therefore if the output capacitor's two pins were not very near the chip's Vout pin and GND pin, Vout's stable would be affected. User will find that the output voltage will drop when load grows up if the output capacitor's two pins are not very near the chip's Vout pin and GND pin. In this condition, 1nF ceramic capacitor is recommended at very near the chip's Vout pin and GND pin. So in all ACE705 application, two capacitors are needed to obtain stable output voltage. The 100µF tantalum output capacitor is recommended to stable output voltage nearby load. The 1nF Vout pin to GND pin ceramic filter capacitor is recommended to stable chip's sense voltage.

### Test Circuits

#### (1) Output voltage test circuit

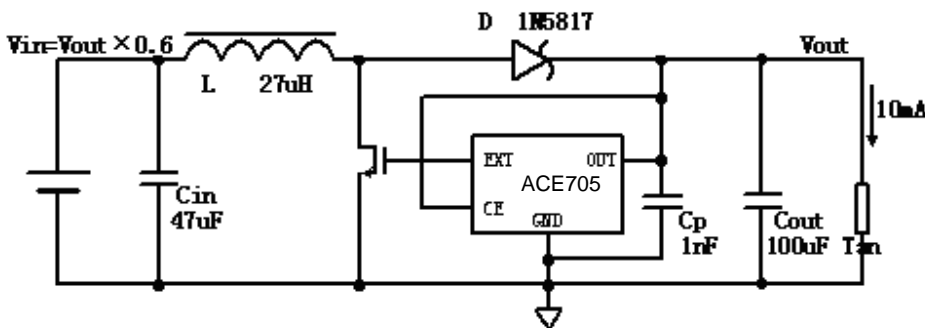

Figure 3

#### (2) Quiescent current test circuit

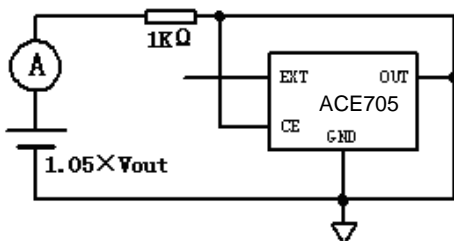

Figure 4

#### (3) Input Current (no load) test circuit

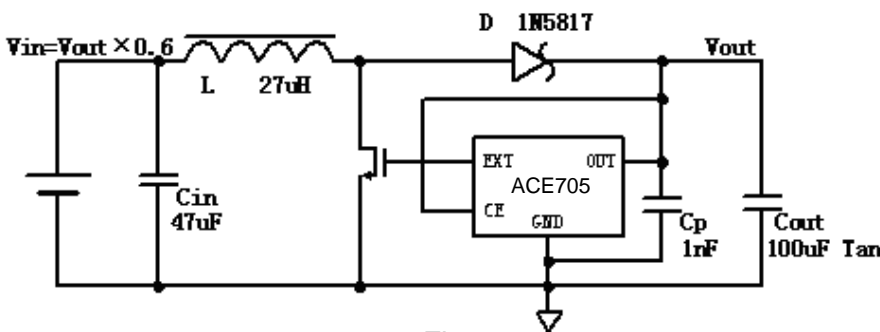

Figure 5





(4) Oscillator frequency and duty cycle test circuit

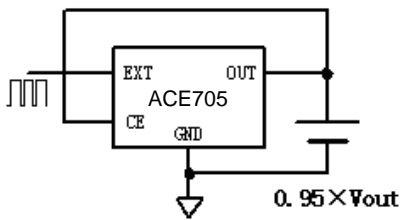

Figure 6

**Extend Applications**

(1) 12V step-up application

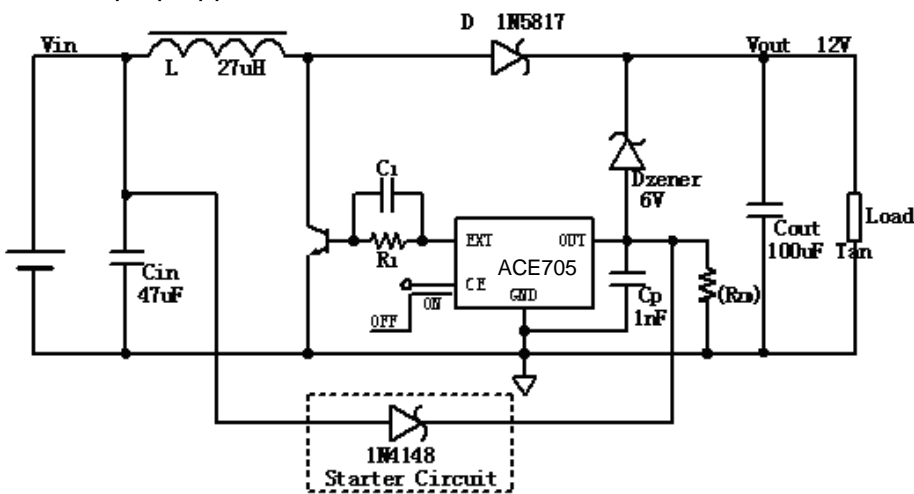

Figure 7

Note: ACE705's output voltage is 6V. When the output current is small or no load, the output voltage will be unstable, use the  $R_{ZD}$  for flowing the bias current through the zener diode. For step-up application, a diode(for example: 1N4148) is needed as starter circuit.



# ACE705

## High efficiency, Low supply current, step-up DC/DC Controller

### (2) Step-down application

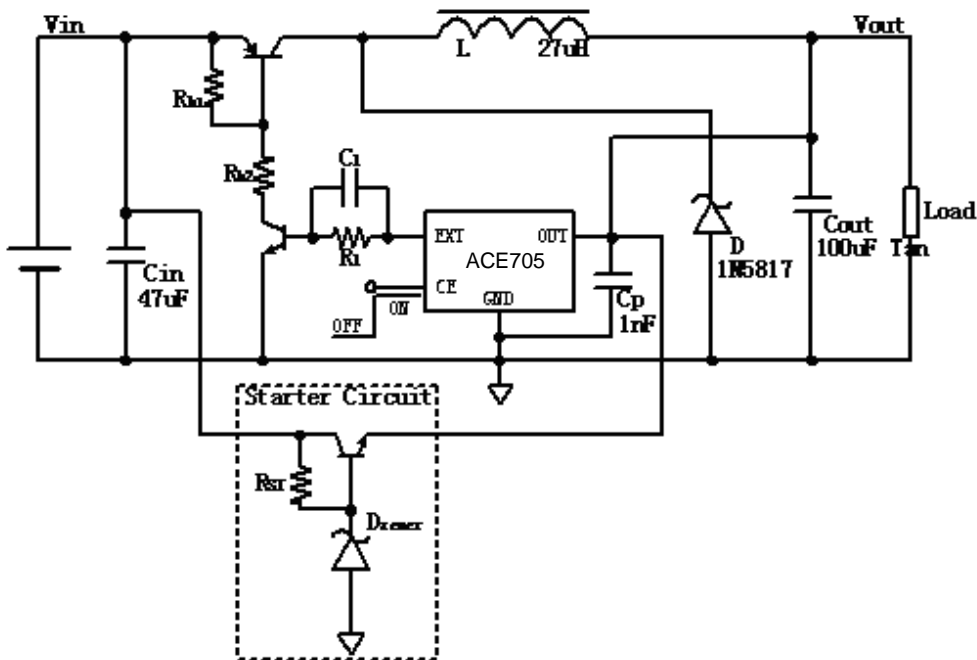

Figure 8

Note: In step-down application, use starter circuit as above.  $2.5V \leq V_{zener} \leq V_{out}$ .  $R_{ST}$  is needed for bias current of zener diode. This starter circuit also can be used in high voltage step-up application.

### (3) Flyback step-up/step-down application

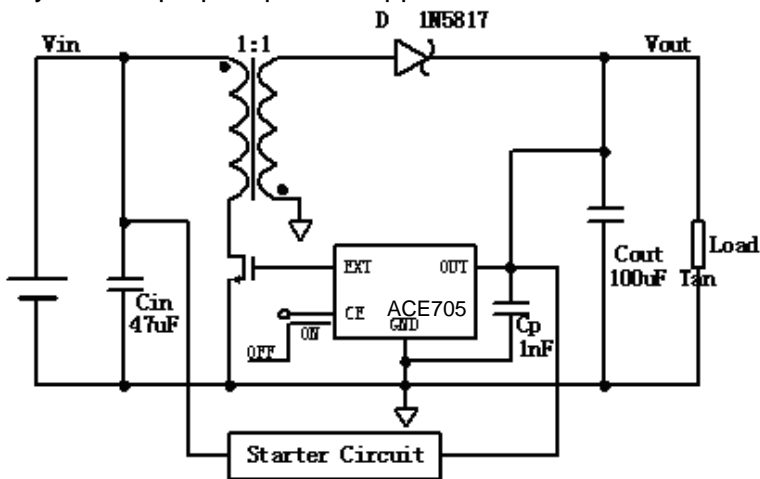

Figure 9

Note: In step-down and step-up/step-down application, starter circuit in fig 8 is need. In step-up application, simpler starter circuit in fig 9 can be used.



### Typical Characteristic

(Recommended operating conditions: L=10uH, Cin=47uF, Cout=100uF, Cp=1nF, Topt=25°C, unless otherwise noted)

#### 1. Output Voltage VS. Output Current

ACE705230BN+ Output Voltage VS. Output Current

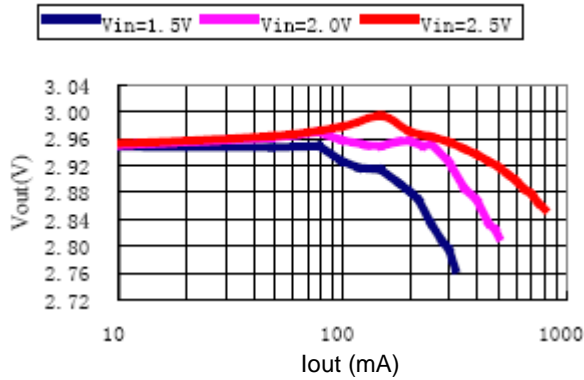

#### 2. Output Voltage VS. Output Current

ACE705260BN+ Output Voltage VS. Output Current

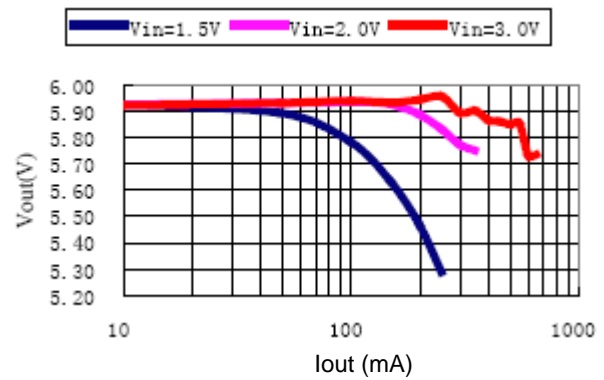

#### 3. Efficiency VS. Output Current

ACE705230BN+ Efficiency VS. Output Current

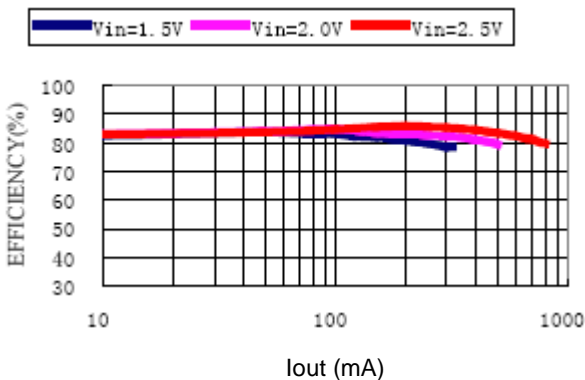

#### 4. Efficiency VS. Output Current

ACE705260BN+ Efficiency VS. Output Current

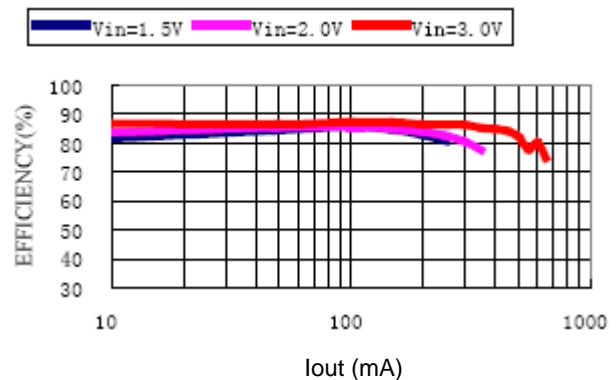

#### 7. Ripple VS. Output Current

ACE705230BN+ Ripple VS. Output Current

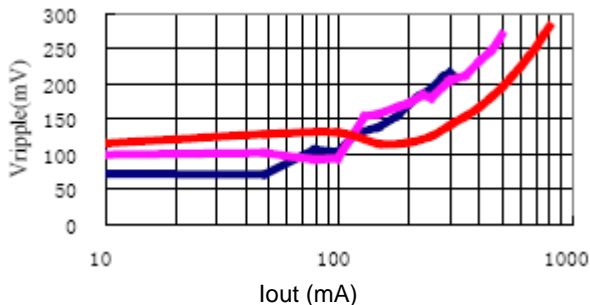

#### 8. Ripple VS. Output Current

ACE705260BN+ Ripple VS. Output Current

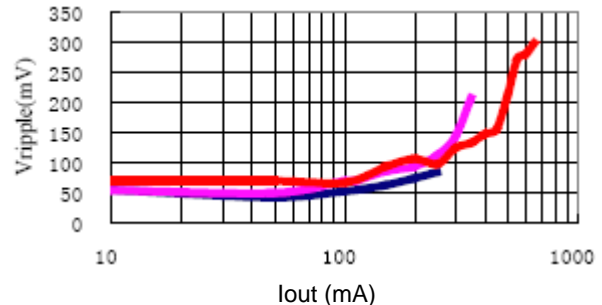



# ACE705

High efficiency, Low supply current, step-up DC/DC Controller

## Packing Information

### SOT-23-3

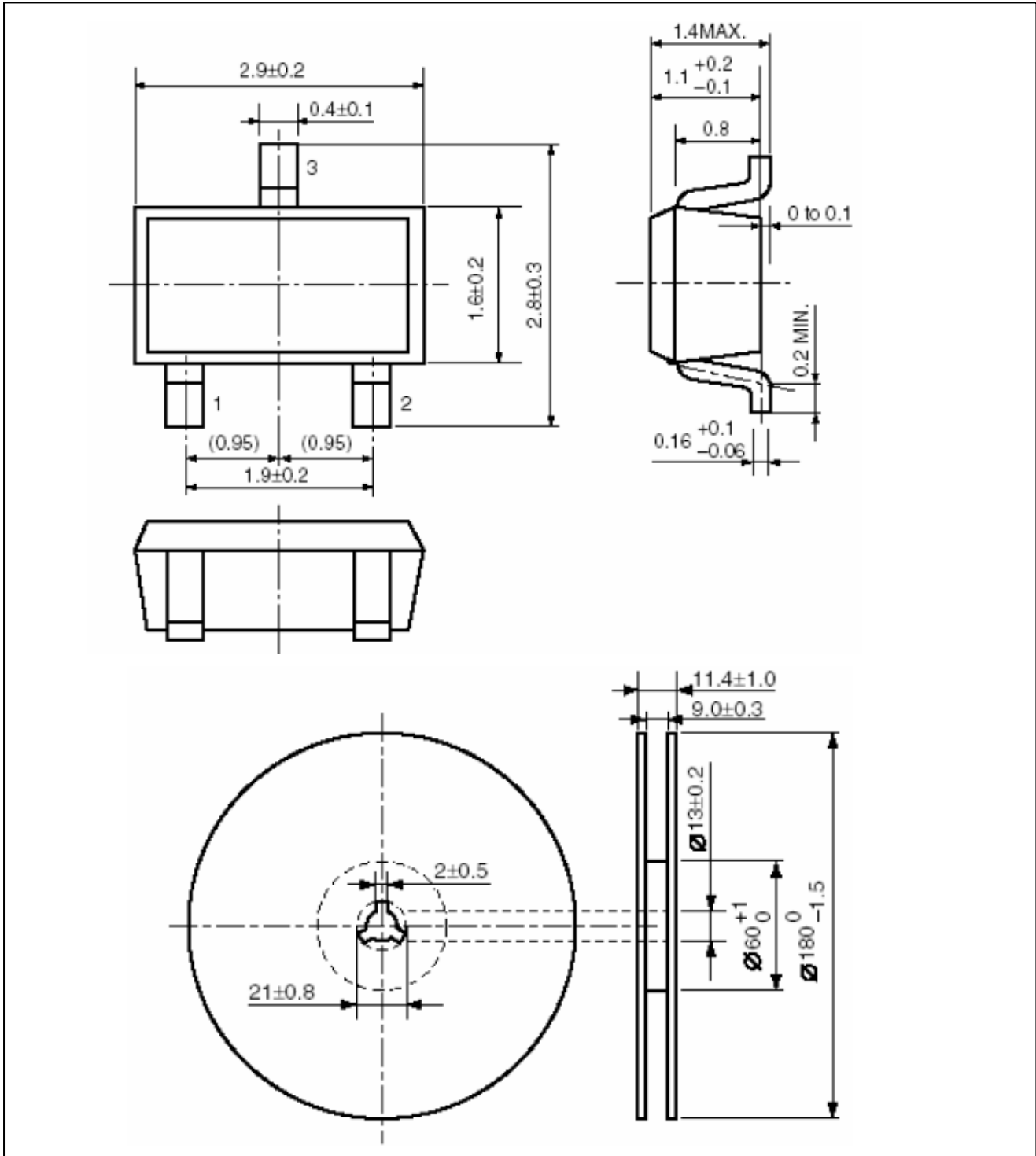



# ACE705

High efficiency, Low supply current, step-up DC/DC Controller

## Packing Information

### SOT-23-5

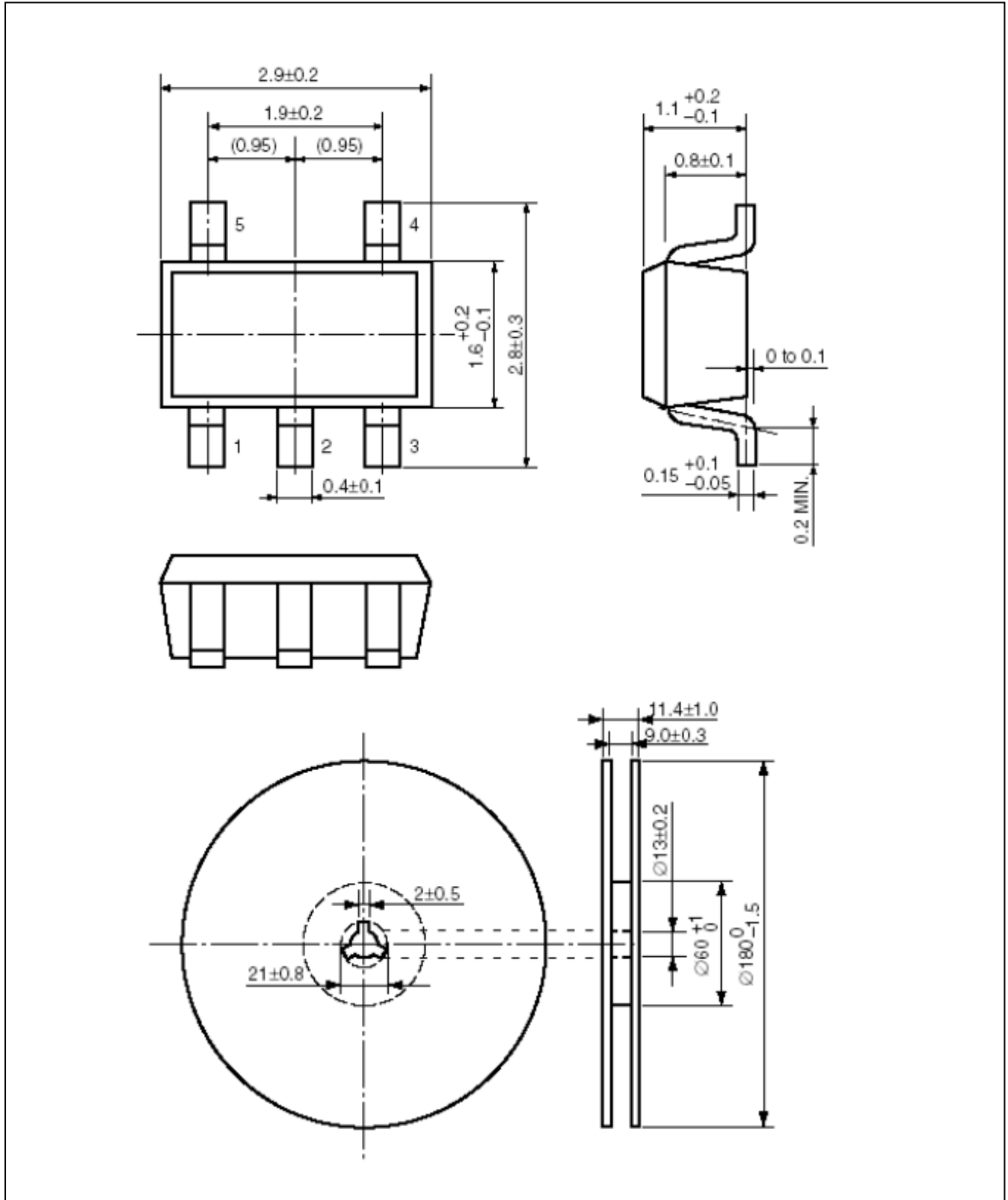



## ACE705

High efficiency, Low supply current, step-up DC/DC Controller

### Notes

ACE does not assume any responsibility for use as critical components in life support devices or systems without the express written approval of the president and general counsel of ACE Electronics Co., LTD. As sued herein:

1. Life support devices or systems are devices or systems which, (a) are intended for surgical implant into the body, or (b) support or sustain life, and whose failure to perform when properly used in accordance with instructions for use provided in the labeling, can be reasonably expected to result in a significant injury to the user.
2. A critical component is any component of a life support device or system whose failure to perform can be reasonably expected to cause the failure of the life support device or system, or to affect its safety or effectiveness.

ACE Technology Co., LTD.  
<http://www.ace-ele.com/>