



ACE714

High Efficiency Low Noise PFM Step-up DC/DC Converter

Description

The ACE714 variable frequency step-up Converter drives white LEDs with a constant current to provide backlight in cell phones, PDAs, and other handheld devices. It features allowing series connection of the white LEDs so that the LED currents are identical for uniform brightness. An enable input can be pulsed repeatedly to adjust LEDs brightness. The fast 3MHz operation frequency allows for smaller capacitor and inductor. Fault condition protection uses cycle-by cycle current limiting to sense maximum inductor current and over-voltage protection. The 0.2V low reference voltage minimized the power loss across the current sense resistor.

The converter can operate from 2V to 6V, and capable of delivering maximum 200mA output current at 4-LEDs application with 3V input voltage is as low as 120uA. All of these features make ACE714 be suitable for the portable devices, which are supplied by a single battery.

Features

- Up to 24V Output Voltage
- Wide Operation Range: 2V to 6V
- Maximum 3MHz Operating Frequency
- PWM Dimming Control
- Shutdown Current <1uA
- Current Limit Cycle-by-Cycle
- Low Current Sense Threshold: 200mV
- 24V Over Output Voltage Protection

Application

- Compact Back Light Module
- Power Source for LED
- Constant Current Source

Typical Application

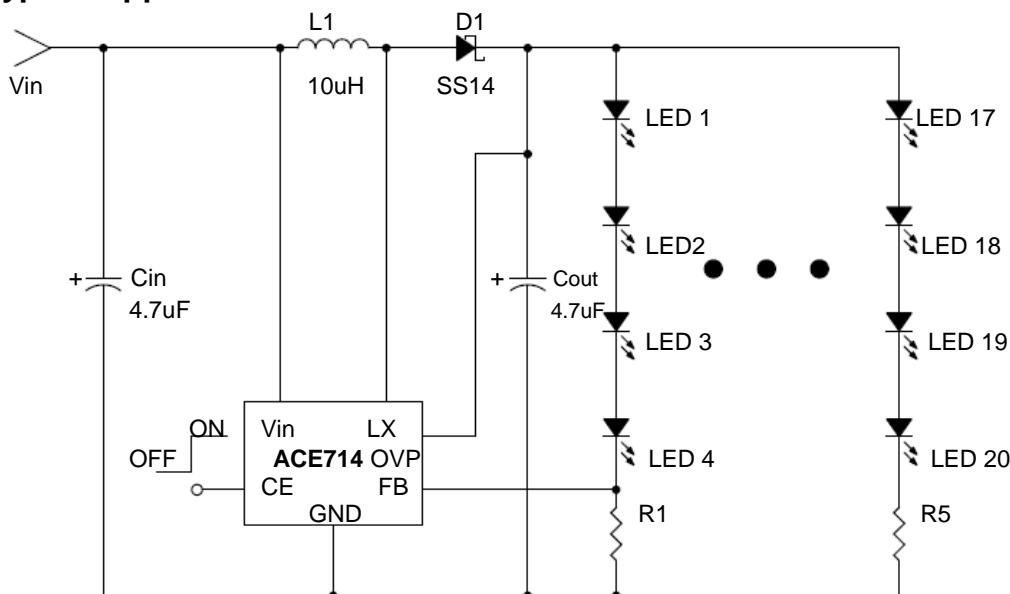

Figure 1. ACE714 Typical Application Circuit



ACE714

High Efficiency Low Noise PFM Step-up DC/DC Converter

Absolute Maximum Ratings

Parameter	Max
Input voltage	-0.3 to 8
CE Pin Voltage	-0.3 to (Vin+0.3V)
Lx Pin Output Current	1.6A
Lx Pin Voltage	24V
Operating Junction Temperature (T _J)	125°C
Ambient Temperature (T _A)	-40°C to 85°C
Power Dissipation SOT-23-6	250mW
Storage Temperature (T _s)	-40°C to 150°C

Packaging Type

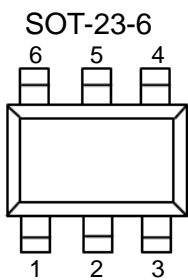

SOT-23-6	Description	Function
1	LX	Switching Pin
2	GND	Ground Pin
3	FB	Pin for Feedback Voltage
4	CE	Chip Enable Pin (Active with "H"), connect to VIN if not used
5	OVP	Over Voltage Protection
6	VIN	Power Supply Pin

Ordering Information

ACE714 XX + H

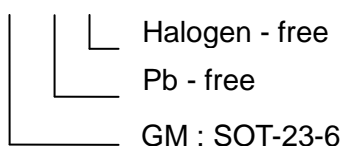



ACE714

High Efficiency Low Noise PFM Step-up DC/DC Converter

Block Diagram

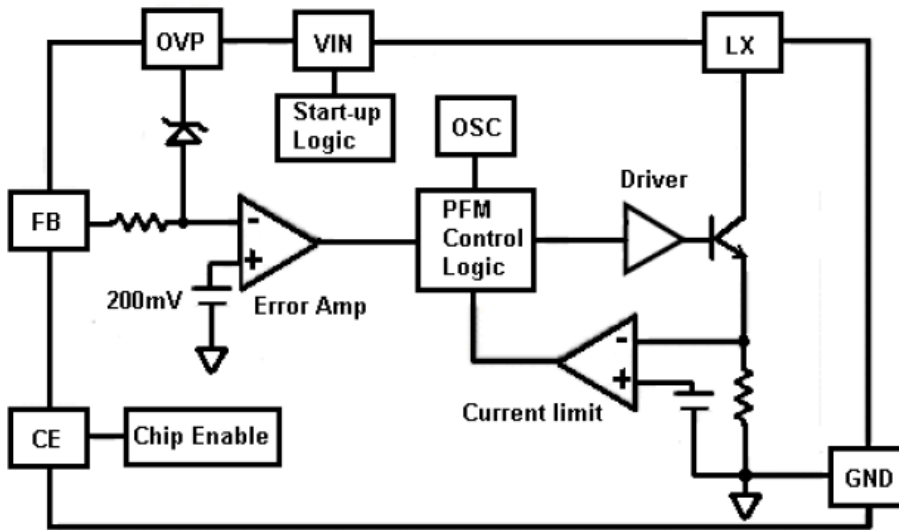

Electrical Characteristics

($T_A=25^\circ\text{C}$, $V_{IN}=3\text{V}$, $V_{CE}=3\text{V}$, unless otherwise noted)

Parameter	Symbol	Conditions	Min	Typ	Max	Units
Operating Input Voltage	V_{IN}		2		6	V
Feedback Voltage	V_{FB}		0.19	0.20	0.21	V
FB Pin Bias Current	I_{FB}		10	45	100	nA
Quiescent Current	I_Q	$V_{FB}=0.3\text{V}$		93	120	uA
		$V_{CE}=0\text{V}$		0.4	1.0	
Maximum switching Frequency	F_{MAX}	$V_{FB}=0\text{V}$, Floating OVP Pin		3		MHz
Switching Current Limit	I_{LIMIT}			1.6		A
Switch V_{CESAT}	V_{CESAT}	$I_{LX}=300\text{mA}$		260		mV
Switching pin Leak Current	I_{LX}	$V_{LX}=5\text{V}$		0.11		uA
CE Voltage High	V_{CEH}	$V_{CE}=0$ to 3V	1.5			V
CE Voltage Low	V_{CEL}	$V_{CE}=3$ to 0V			0.4	V
CE Pin Bias Current	I_{CE}	$V_{IN}=V_{CE}=3\text{V}$		18		uA
Over Voltage Protection	V_{OVP}			24		V



Typical Performance Characteristics

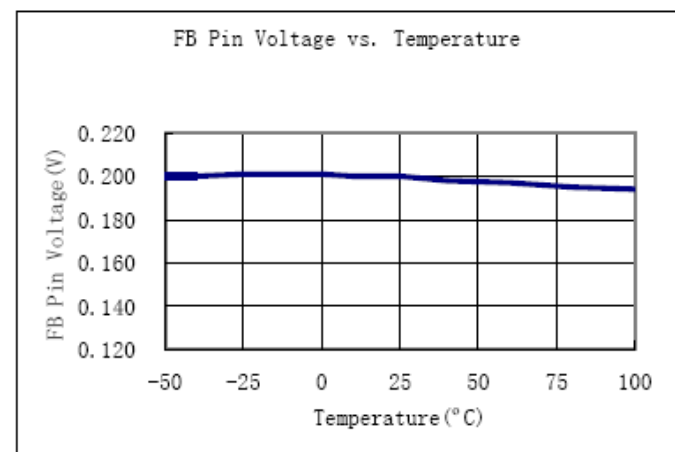
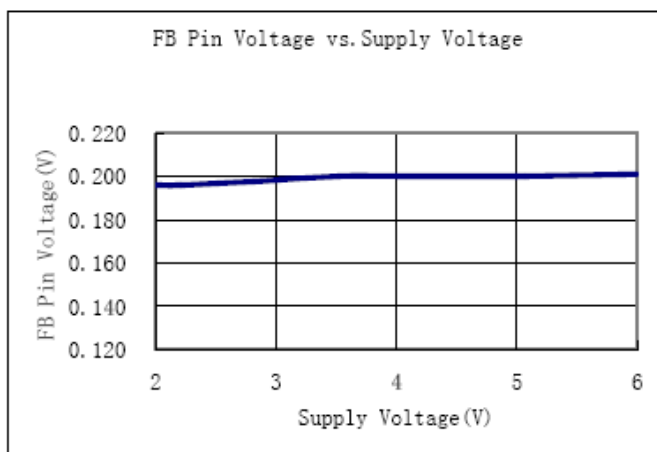
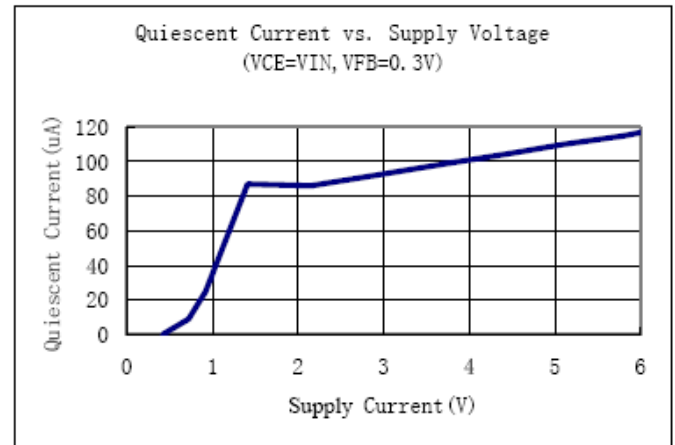
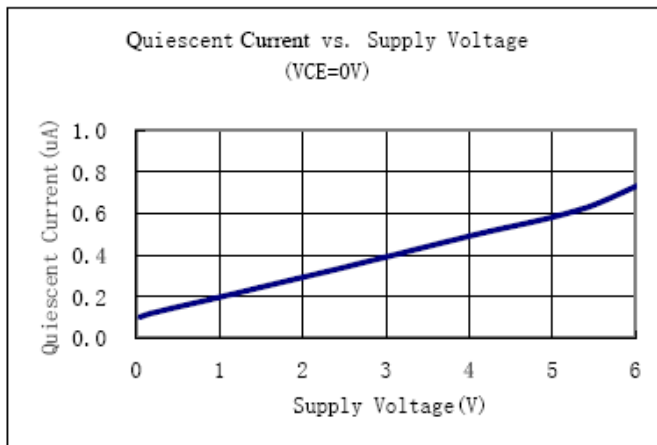
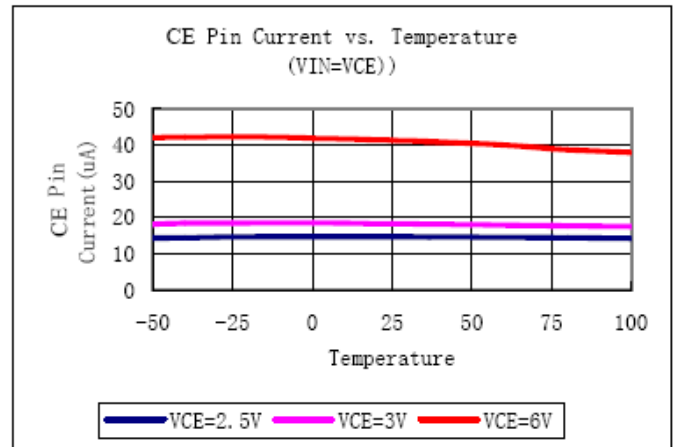
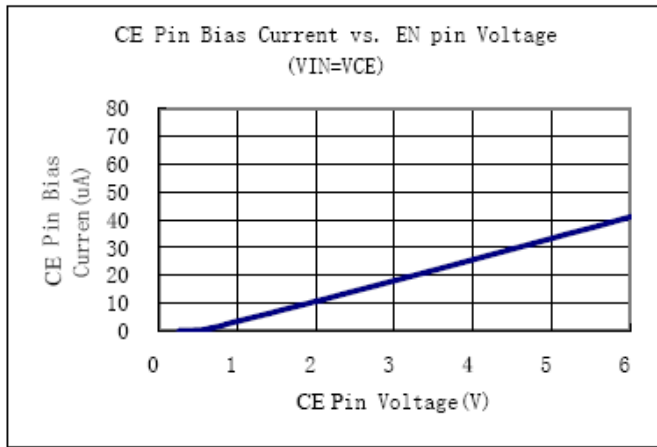



Typical Performance Characteristics

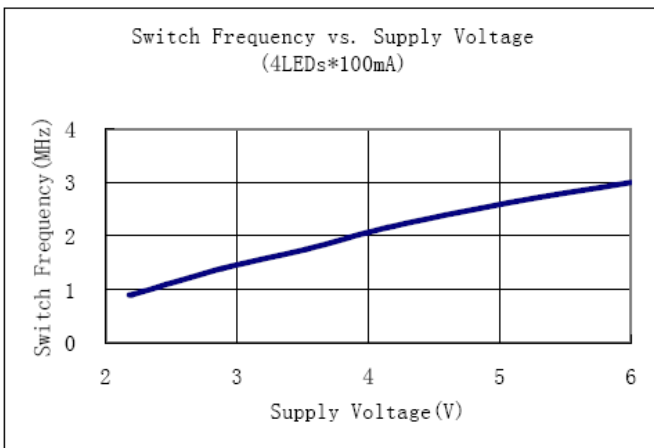
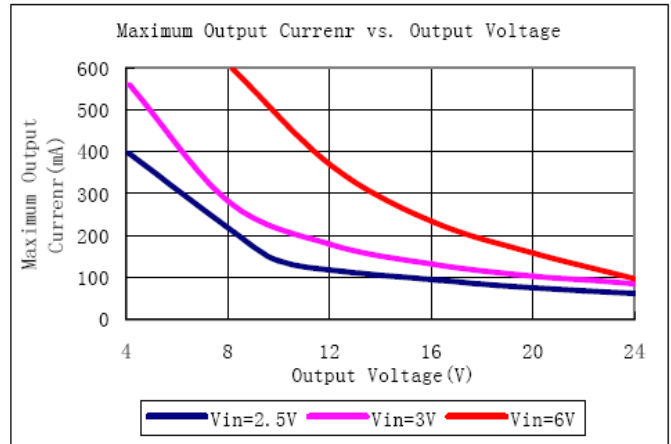
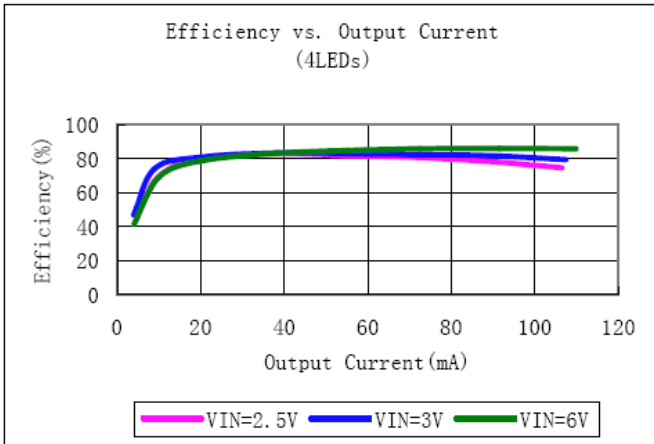

Application Information

Dimming Control

1. Using a PWM Signal to CE Pin

When adding the PWM signal to CE pin, the ACE714 is turned on or off by the PWM signal, so the LEDs operate at either zero or full current. The average LED current increase proportionally with the duty cycle of the PWM signal. The frequency range of the PWM signal is from 1 kHz to 300kHz.

2. Using a DC Voltage

From the Figure 2, we can add a DC voltage to FB pin, we adjust the LED current by changing the DC voltage, which control the brightness, DC voltage range is from 0V to 2V.

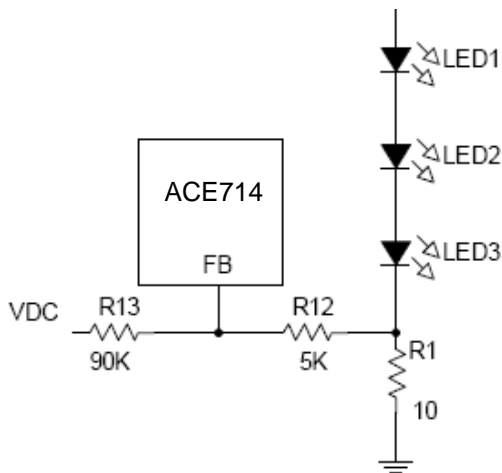

Figure 2. Dimming Control Using a DV Voltage

3. Using a Filtered PWM Signal

The filtered PWM signal can be considered as an adjustable DC voltage. It can be used to replace the variable DC voltage source in dimming control. The circuit is shown in Figure 3.

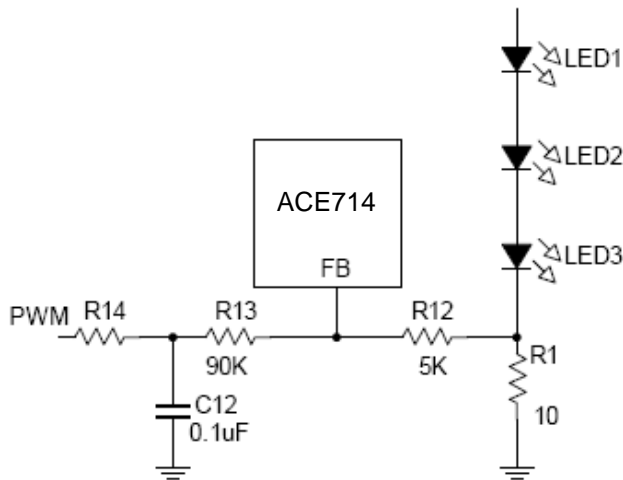

Figure 3. Dimming Control Using a Filtered PWM Signal



ACE714

High Efficiency Low Noise PFM Step-up DC/DC Converter

4. PCB Layout

Layout is critical to achieve clean and stable operation. The switching power stage requires particular attention. Follow these guidelines for good PC board layout:

- 1) Place decoupling capacitors as close to the IC as possible.
- 2) Connect input and output capacitors to the same power ground node with a star ground configuration then to IC ground.
- 3) Keep the high-current paths as short and wide as possible.
- 4) If possible, connect IN, SW, and GND separately to a large copper area to help cool the IC to further improve efficiency and long-term reliability.
- 5) Ensure all feedback connections are short and direct. Place the feedback resistors as close to the IC as possible.
- 6) Route high-speed switching nodes away from sensitive analog areas

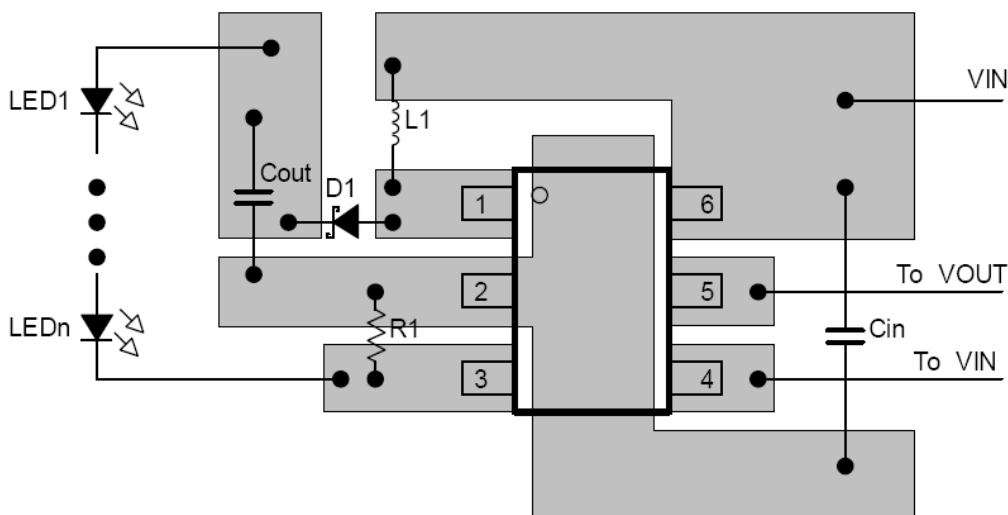

Figure 4. Recommended Component Placement



ACE714

High Efficiency Low Noise PFM Step-up DC/DC Converter

Packing Information

SOT-23-6

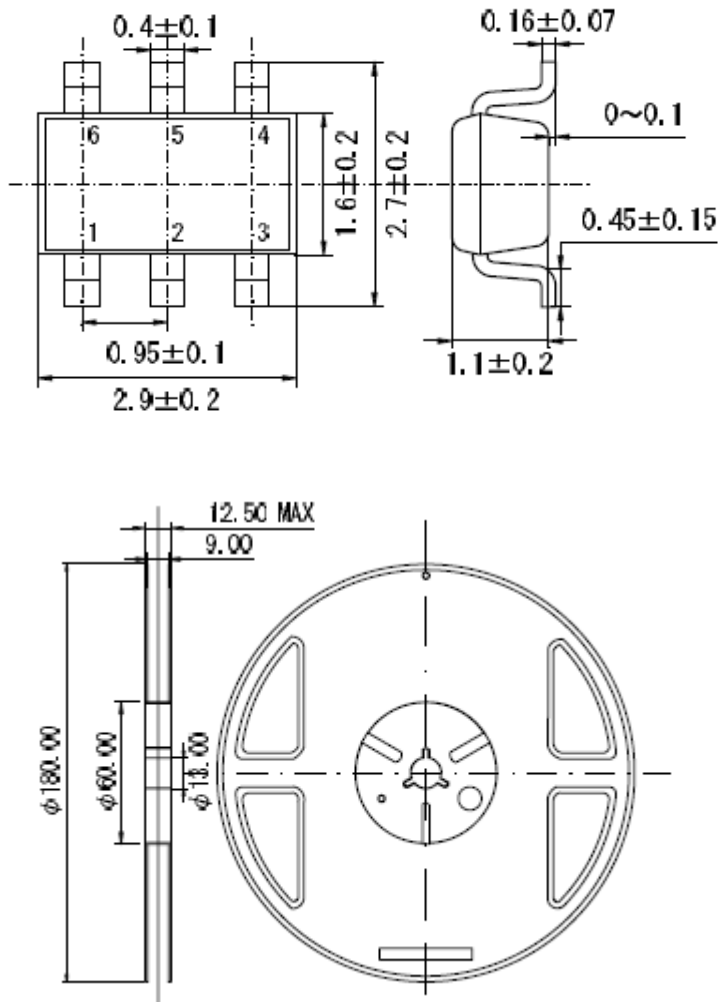



ACE714

High Efficiency Low Noise PFM Step-up DC/DC Converter

Notes

ACE does not assume any responsibility for use as critical components in life support devices or systems without the express written approval of the president and general counsel of ACE Electronics Co., LTD. As sued herein:

1. Life support devices or systems are devices or systems which, (a) are intended for surgical implant into the body, or (b) support or sustain life, and whose failure to perform when properly used in accordance with instructions for use provided in the labeling, can be reasonably expected to result in a significant injury to the user.
2. A critical component is any component of a life support device or system whose failure to perform can be reasonably expected to cause the failure of the life support device or system, or to affect its safety or effectiveness.

ACE Technology Co., LTD.
<http://www.ace-ele.com/>