

Description

The ACE721A is a 1.2MHz fixed frequency, current mode, PWM synchronous buck (step-down) DC-DC converter, capable of driving a 800mA load with high efficiency, excellent line and load regulation. The device integrates a main switch and a synchronous switch without an external Schottky diode. It is ideal for powering portable equipment that runs from a single Li-ion battery.

A standard series of inductors are available from several different manufactures optimized for use with the ACE721A. This feature greatly simplifies the design of switch-mode power supplies.

This IC is available in SOT-23-5 packages.

Features

- High Efficiency: up to 95%
- Output Current: 800mA
- Input Voltage Range: 2.5V to 5.5V
- Fixed 1.2MHz Frequency
- Current Mode Control
- 100% Duty Cycle in Dropout
- Built-in Short Circuit Protection
- Built-in Thermal Shutdown Function
- Built-in Current Limit Function
- Shutdown Current: $<1 \mu A$

Application

- GPS
- WiFi Card
- Portable Media Player
- Digital Still and Video Cameras

Absolute Maximum Ratings

Parameter	Symbol	Value	Unit
Input Voltage	V_{IN}	-0.3 to 6	V
Feedback Voltage	V_{FB}	-0.3 to $V_{IN}+0.3$	V
EN Pin Voltage	V_{EN}	-0.3 to $V_{IN}+0.3$	V
SW Pin Voltage	V_{SW}	-0.3 to $V_{IN}+0.3$	V
Thermal Resistance	θ_{JA}	SOT-23-5 250	$^{\circ}C/W$
Operating Junction Temperature	T_J	125	$^{\circ}C$
Storage Temperature	T_{STG}	-65 to 150	$^{\circ}C$

Note 1: Stresses greater than those listed under “Absolute Maximum Ratings” may cause permanent damage to the device. These are stress rating only, and functional operation of the device at these or any other conditions beyond those indicated under “Recommended Operating Conditions” is not implied. Exposure to “Absolute Maximum Ratings” for extended periods may affect device reliability.

Packaging Type

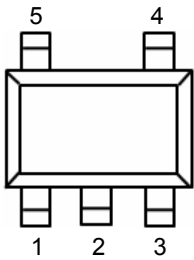

Pin	SOT-23-5
1	EN
2	GND
3	SW
4	V _{IN}
5	FB

Ordering information

Selection Guide

ACE721A XX XX + H

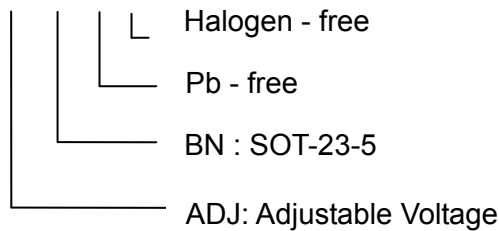

Functional Block Diagram

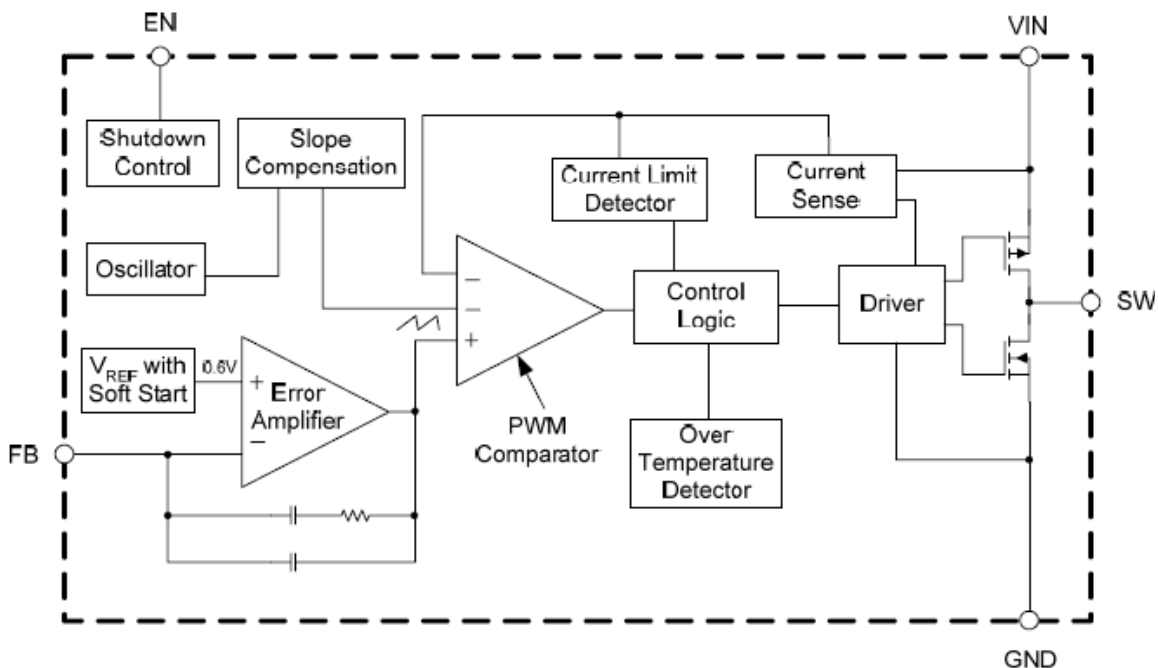

Recommended Work Conditions

Item	Min	Typ	Max	Unit
Input Voltage (V_{IN})	2.5		5.5	V
Maximum Output Current ($I_{OUT(MAX)}$)	800			mA
Operating Ambient Temperature (T_A)	-40		85	°C

Electrical Characteristics

$V_{IN}=V_{EN}=3.6V$, $T_A=25^{\circ}C$, unless otherwise specified. Specifications with boldface type apply over full operating temperature range from -40 to $85^{\circ}C$

Parameter	Symbol	Conditions	Min.	Typ.	Max.	Unit
Supply Current	I_{CC}	$V_{FB}=0.55V$		400	600	μA
Shutdown Supply Current	I_{SHDN}	$V_{EN}=0V$, $V_{IN}=5.5V$		0.01	1	μA
Under Voltage Lockout Threshold	V_{UVLO}	Rising edge		2.27		V
Under Voltage Lockout Hysteresis	V_{HUVLO}			200		mV
Feedback Bias Current	I_{FB}	$V_{FB}=0.65V$	-50	0.5	50	nA
Feedback Voltage	V_{FB}	$I_{OUT}=100mA$	0.588 / 0.582	0.600	0.612 / 0.618	V
Maximum Output Current	$I_{OUT(MAX)}$	$V_{IN}=2.5V$, $V_{OUT}=0.9V$	800			mA
		$V_{IN}=3.6V$, $V_{OUT}=1.2V$	800			
		$V_{IN}=4.6V$, $V_{OUT}=3.3V$	800			
Switch Current Limit	I_{LIM}	$V_{FB}=0.55V$	0.85	1.15		A
Oscillator Frequency	f_{OSC}		0.8	1.2	1.4	MHz
EN Pin Threshold	V_{ENL}				0.6	V
	V_{ENH}		1.5			
EN Pin Input Leakage Current	I_H	$V_{EN}=3.6V$	-0.1		0.1	μA
	I_L	$V_{EN}=0V$	-0.1		0.1	
Internal PFET On Resistance	R_{DSONP}	$I_{SW}=100mA$		0.44		Ω
Internal NFET On Resistance	R_{DSONN}	$I_{SW}=-100mA$		0.29		Ω
Maximum Duty Cycle	D_{MAX}	$V_{FB}=0.55V$		100		%
Soft-start Time	T_{SS}	$V_{EN}=0V$ to V_{IN} $I_{OUT}=50mA$		220		μS
Thermal Shutdown Threshold	T_{OTSD}			160		°C
Thermal Shutdown Hysteresis	T_{HYS}			30		°C

Typical Application Circuit

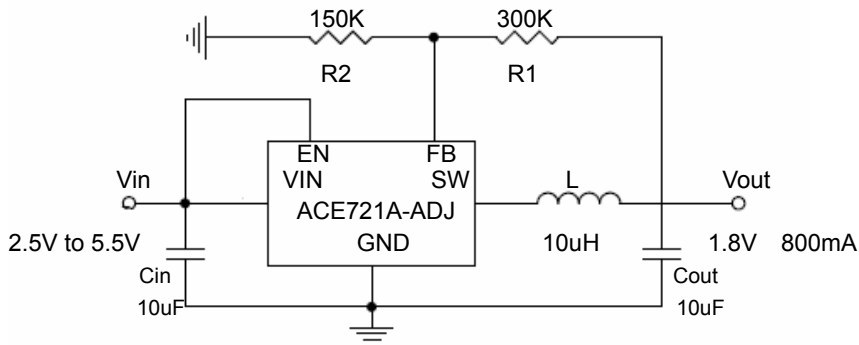

Typical Performance Characteristics

L=10 μ H, COUT=10 μ F, TA=25 $^{\circ}$ C, unless otherwise noted.

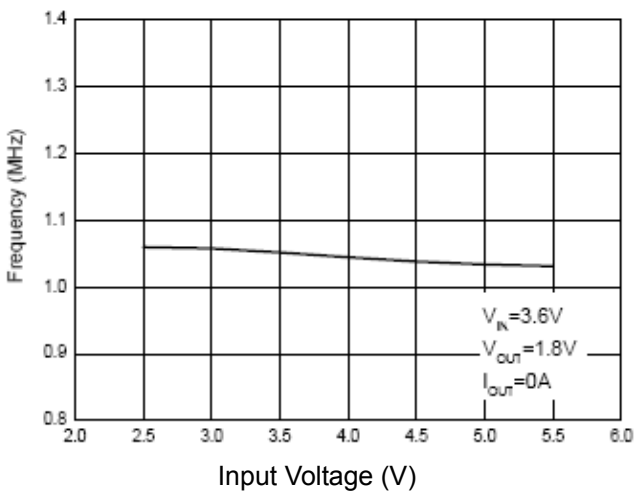

Figure 1. Frequency vs. Input Voltage

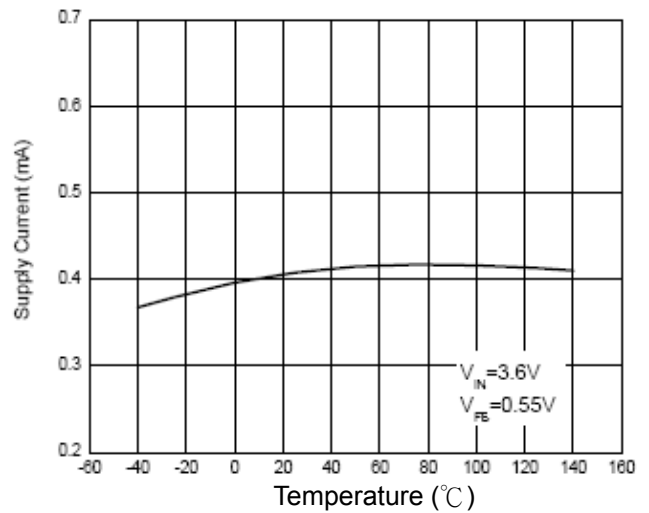

Figure 2. Supply Current vs. Temperature

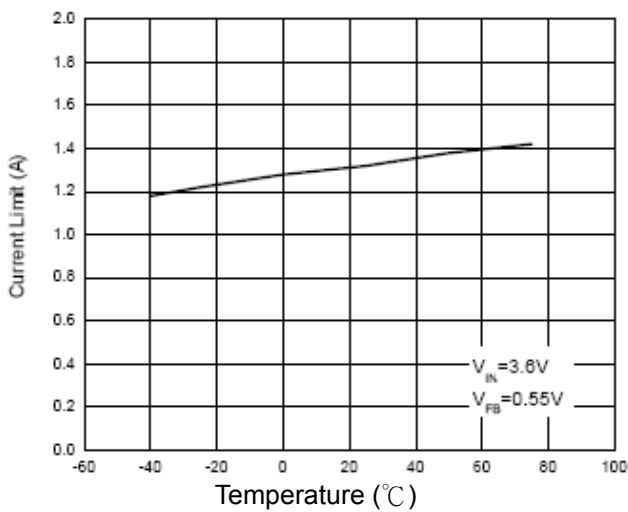

Figure 3. Current Limit vs. Temperature

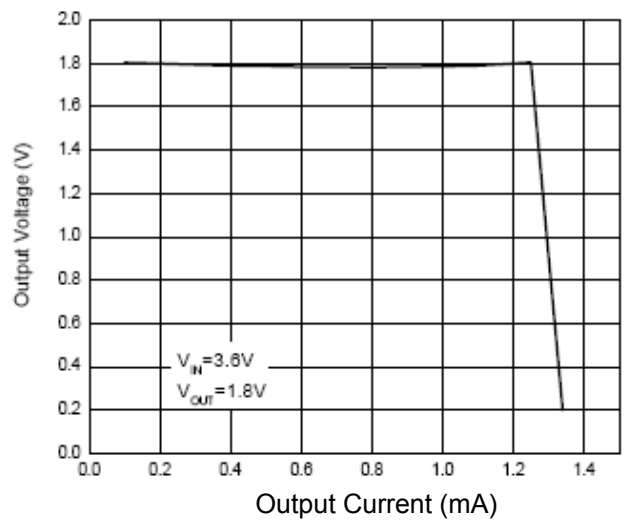
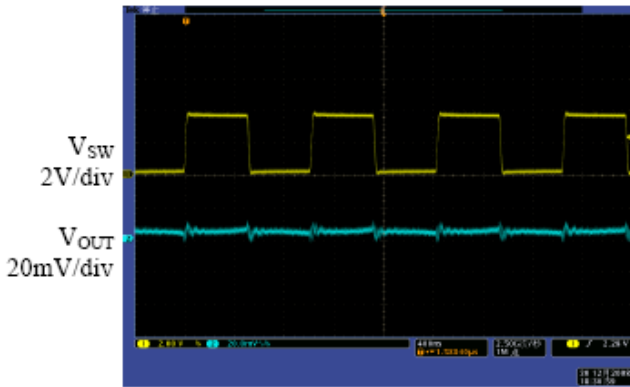
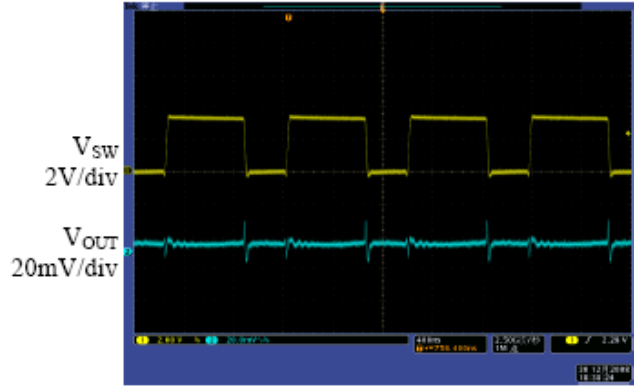

Figure 4. Output Voltage vs. Output Current



400ns/div

Figure 5. Light Load Operation
($V_{IN}=3.6V$, $V_{OUT}=1.8V$, $I_{OUT}=0mA$)



400ns/div

Figure 6. Heavy Load Operation
($V_{IN}=3.6V$, $V_{OUT}=1.8V$, $I_{OUT}=800mA$)

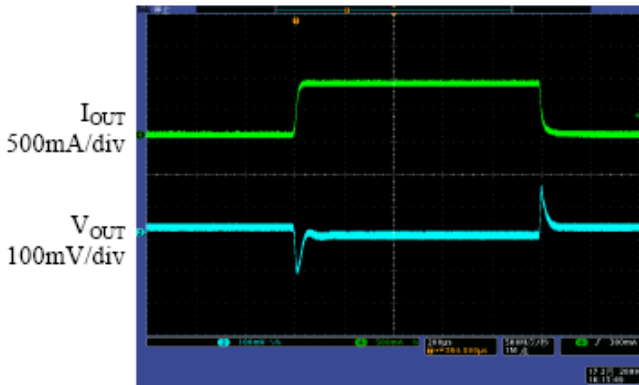

200µs/div

Figure 7. Load Transient
($V_{IN}=3.6V$, $V_{OUT}=1.8V$, $I_{OUT}=0mA$ to $800mA$)

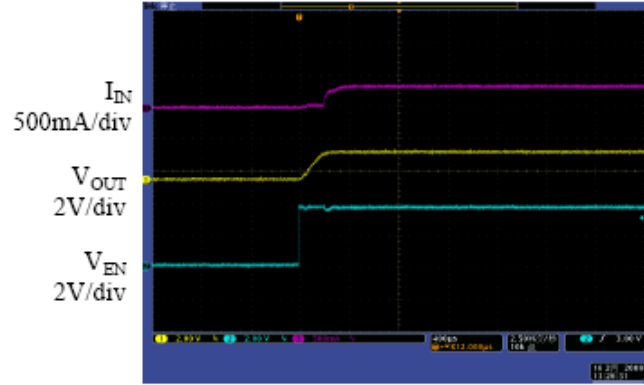

400µs/div

Figure 8. Start up from Shutdown
($V_{IN}=3.6V$, $V_{OUT}=1.8V$, $R_{LOAD}=2.5\Omega$)

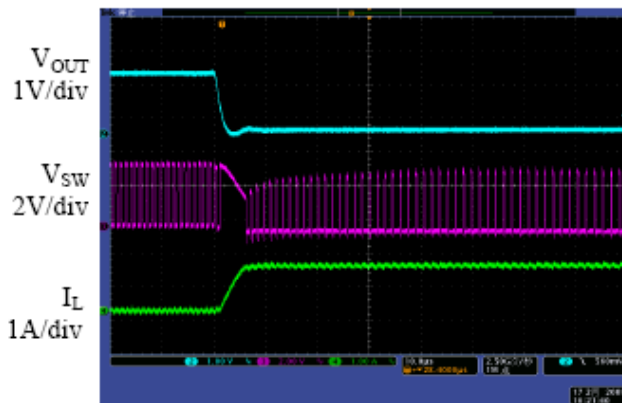

10µs/div

Figure 9. Short Circuit Protection
($V_{IN}=3.6V$, $V_{OUT}=1.8V$, no load)

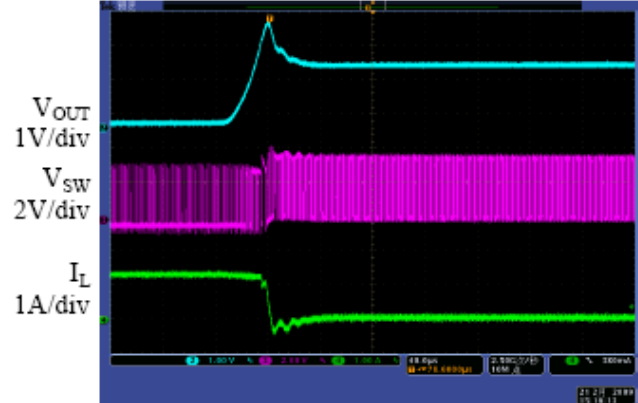

40µs/div

Figure 10. Short Circuit Recovery
($V_{IN}=3.6V$, $V_{OUT}=1.8V$, no load)

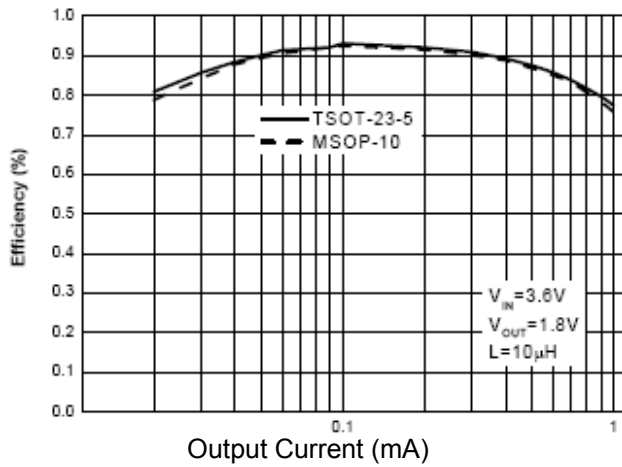

Figure 11. Efficiency vs. Output Current

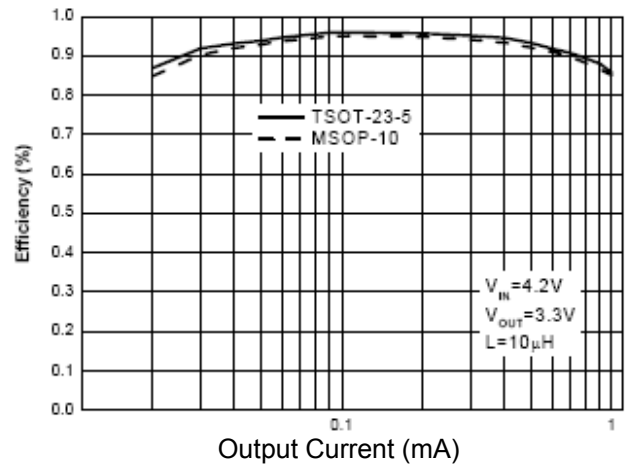

Figure 12. Efficiency vs Output Current

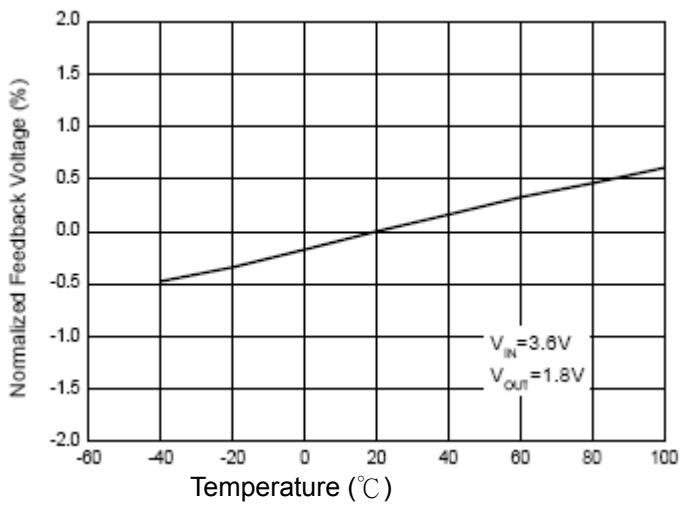
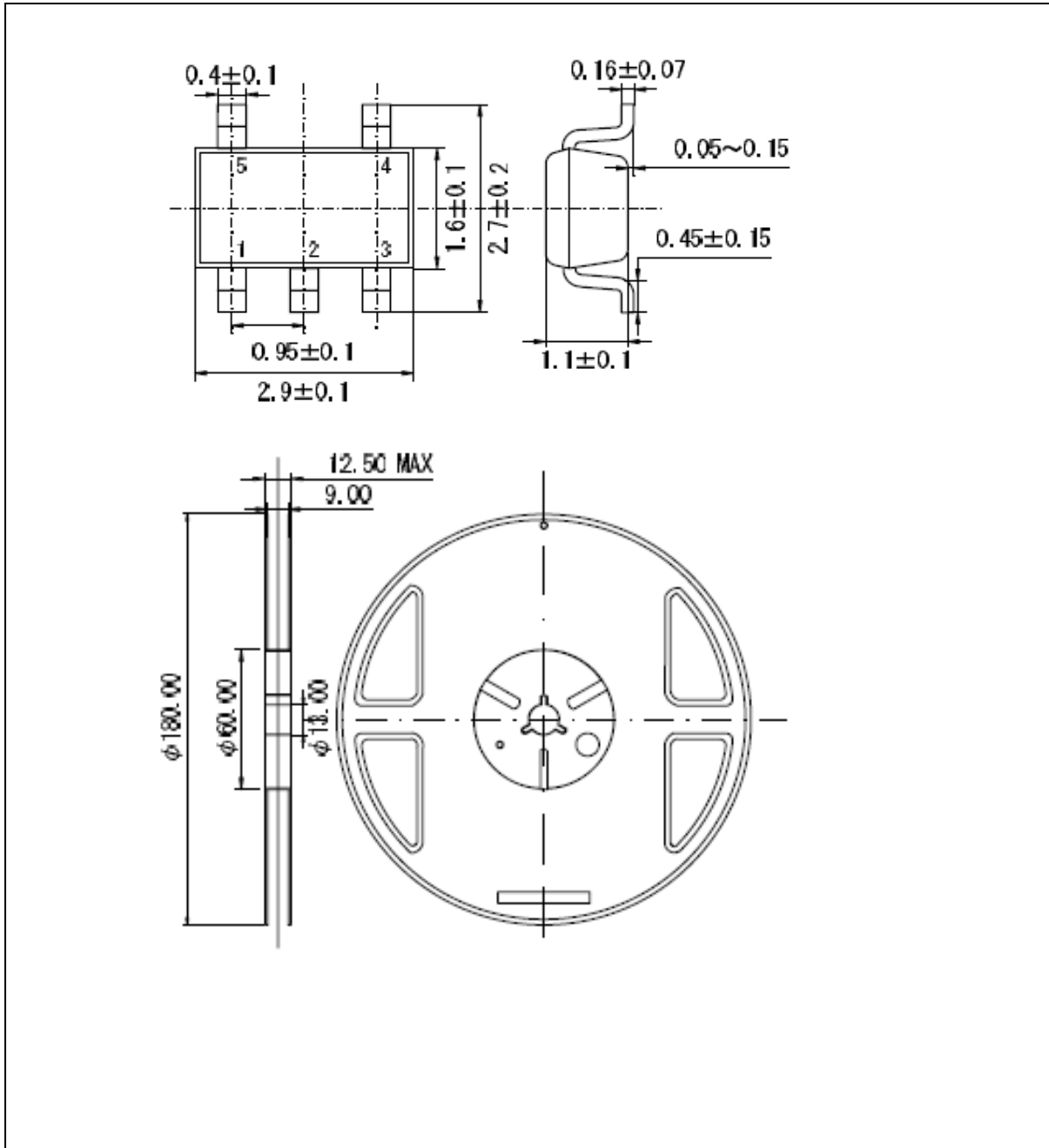

Figure 13. Normalized Feedback Voltage vs. Temperature

Packing Information

SOT-23-5



Notes

ACE does not assume any responsibility for use as critical components in life support devices or systems without the express written approval of the president and general counsel of ACE Electronics Co., LTD. As sued herein:

1. Life support devices or systems are devices or systems which, (a) are intended for surgical implant into the body, or (b) support or sustain life, and whose failure to perform when properly used in accordance with instructions for use provided in the labeling, can be reasonably expected to result in a significant injury to the user.
2. A critical component is any component of a life support device or system whose failure to perform can be reasonably expected to cause the failure of the life support device or system, or to affect its safety or effectiveness.

ACE Technology Co., LTD.

<http://www.ace-ele.com/>