



ACE752D

120KHz 3.5A Buck DC-DC Converter

Description

The ACE752D is a high efficiency step down DC-DC converter with adjustable current limit in compact SOP-8/ESOP-8 packages, including an error amplifier, ramp generator, current comparator, slope compensation, current sense and logic driver. It also integrates a current error amplifier to have a constant voltage and constant current control. Peak current mode PWM control with external adjustable compensation provides a stable and high efficient operation over a wide range of load currents. By means of an on board current sense resistor and the availability of the current sense pins, a current limit programming is very simple and accurate. The internal robust DMOS transistor with a typical of 150 mΩ assures high efficiency even at high output current level. The internal limiting current of typical value of 3.5 A, output short and over temperature protection, protect the device from accidental damage. The internal fixed switching frequency of 120 kHz, and the SOP-8/ESOP-8 packages pin allow building an ultra compact DC/ DC converter with a minimum board space.

Features

- Up to 2.1A/2.4A output current
- Input Under Voltage Lockout
- Operating voltage can be up to 40V
- 120 kHz Internal Jitter Frequency for lower EMI
- Patent-Technique Constant Voltage and Constant Current Control.
- Patent-Technique Output Voltage Compensation
- Adjustable current limit
- Over Temperature Protection
- Small SOP-8/ESOP-8 Packages

Application

- Car Charger/Adaptor
- Rechargeable Portable Devices
- General-purpose step-down converters with adjustable current limit



ACE752D 120KHz 3.5A Buck DC-DC Converter

Absolute Maximum Ratings (T_{amb}=25°C)

Parameter	Symbol	Max	Unit
V _{IN} Supply Voltage	V _{IN}	+40	V
SW Voltage	V _{SW}	-0.3 ~V _{IN} +0.3	V
BS Voltage	V _{BS}	V _{SW} +8	V
COMP Voltage	V _{COMP}	+5	V
FB Voltage	V _{FB}	+5	V
CS+ Voltage	V _{CS+}	-0.3~+8	V
CS- Voltage	V _{CS-}	-0.3~+8	V
Operating Temperature Range	T _{LEAD}	-20~+85	°C
Storage Temperature Range	T _{STG}	-40 to125	°C

Packaging Type

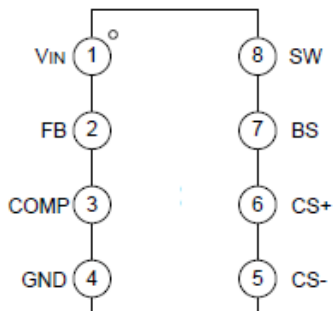

Pin No.	Pin Name	I/O	Pin Description
1	V _{IN}	P	Input Voltage.
2	FB	I	Feedback Input Pin.
3	COMP	I/O	Compensation pin, resistor and capacitor connected.
4	GND	G	Ground.
5	CS-	I	Current sense Pins, current limit resistor connected
6	CS+	I	Current sense Pins, current limit resistor connected
7	BS	I/O	Bootstrap, a 10nF capacitor is connected between BS and SW.
8	SW	O	Switch Pin.
EP	Exposed PAD	G	Heatsink, connected to ground.



ACE752D 120KHz 3.5A Buck DC-DC Converter

Ordering information

ACE752D XX + H

- └─ Halogen - free
- └─ Pb - free
- └─ FM :SOP-8(2.1A)
- └─ IM:ESOP-8(2.4A)

Functional Block Diagram

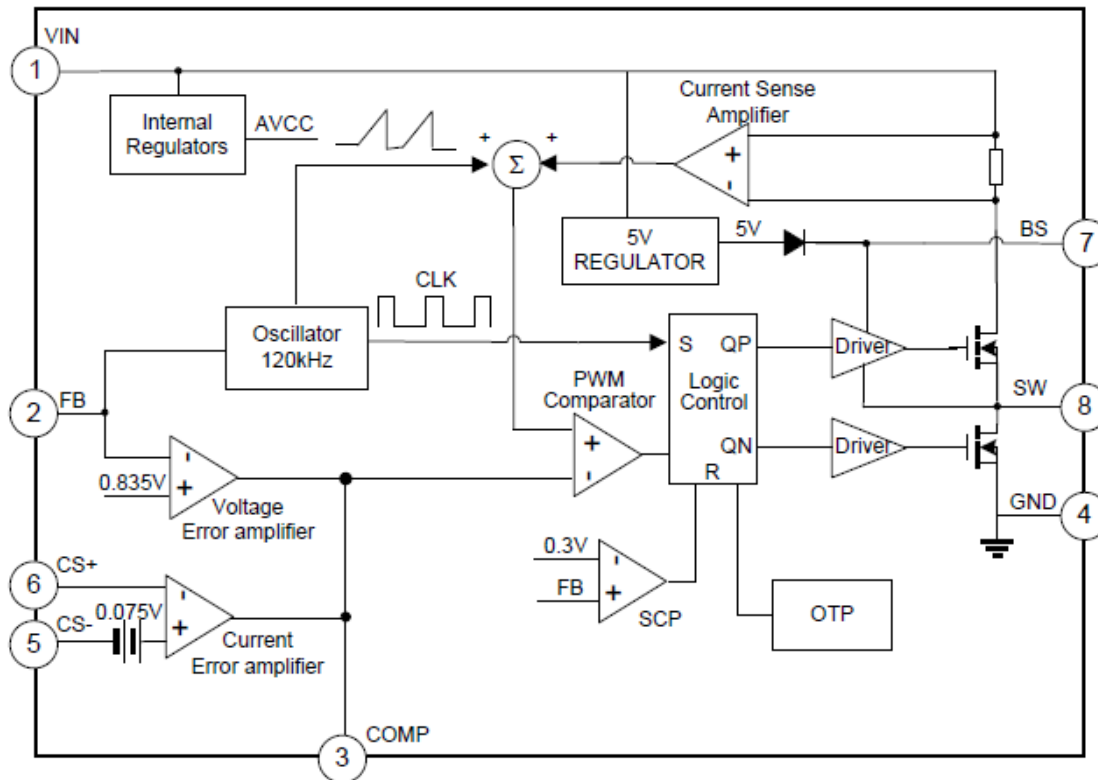



ACE752D

120KHz 3.5A Buck DC-DC Converter

Electrical Characteristics ($T_{amb}=25^{\circ}\text{C}$, $V_{IN}=12\text{V}$, $V_{OUT}=5\text{V}$, Load Current=0, unless otherwise specified)

Parameter	Symbol	Conditions	Min	Typ	Max	Unit
Input Voltage Range	V_{IN}	V_{IN} pin voltage	10		40	V
Feedback Reference Voltage	V_{FB}		0.815	0.835	0.855	V
Feedback Current	I_{FB}	$V_{FB}=0.81\text{V}$		-0.1		μA
Quiescent Current (Switch Off)	$I_{\text{switch off}}$	$V_{FB}=1\text{V}$		0.75	1	μA
Current Sense Offset Voltage	V_{CS}		70	75	80	mA
Switching Frequency	F_S	$V_{FB}=0.6\text{V}$	96	120	144	KHz
NMOS Switch On Resistance	R_{ON}	$V_{SW}=0\text{V}$		0.15	10	Ω
NMOS Switch Leakage Current	I_{leak}				104	μA
NMOS Current Limit	I_{LMT}		3	3.5		A
UVLO Input Rising Voltage	$V_{IN(\text{rising})}$		8	9		V
UVLO o Voltage Hysteresis	$V_{IN(\text{hyst})}$			2		V
Thermal Shutdown Temperature	$T_{j(\text{sd})}$			150		$^{\circ}\text{C}$
Thermal Shutdown Hysteresis	T_{hyst}			20		$^{\circ}\text{C}$
SoftStart Time	T_{SS}			16		mS

FUNCTION DESCRIPTION

The ACE752D is a complete and simple step down DC-DC converter with adjustable current Limit. By means of an on board current sense resistor and the availability of the current sense pins, a current limit programming is very simple and accurate.

Moreover, constant current control can be used to charge batteries. The device can be used as a standard DC-DC converter with adjustable current limit (set by using the external sense resistor).

The internal robust N-channel MOS transistor with a typical value of 150 m Ω assures high efficiency and a minimum dropout even at high output current level. The internal limiting current of typical value of 3.5 A protects the device from accidental overload avoiding dangerous loads damage.

When overload or output short, the main switch is turned on and off periodically to limit the current delivered to the load, protect the load and the device itself. When output short is removed or the load decrease to normal, the output voltage recovers.

If the temperature of the chip goes higher than a fixed internal threshold (150 $^{\circ}\text{C}$ with 20 $^{\circ}\text{C}$ hysteresis), the device is turned off.

The internal fixed switching frequency of 120 kHz, and the small SOP-8/ESOP-8 packages allow building an ultra compact DC-DC converter with a minimum board space.



ACE752D 120KHz 3.5A Buck DC-DC Converter

APPLICATIONS INFORMATION

Output Voltage and Feedback Loop Settings

Refer to the figure 1, the output voltage of the switching regulator (V_{OUT}) can be set with Equation following:

$$V_{OUT} = \left(1 + \frac{R3}{R4}\right) \times 0.835V$$

The limit current is set by the external resistor R2:

$$I_{LIMIT} = \frac{70mV}{R2}$$

The ACE752D uses a patent-pending output voltage compensation scheme for the conductor wire loss by properly selecting the value of R3, R4, if the conductor resistance is R_{line}, current sense resistor is R2 (Refer to the figure1), then:

$$R3 = \frac{R_{line}}{200\mu \times R2}$$

$$R4 = \frac{0.835 \times R3}{V_{OUT} - 0.835}$$

For R_{line}=70mΩ, R2=33.3mΩ (2.1A current limit as figure 1), V_{OUT}=5V:

R3=11k, R4=2.2k, choose R3=10k, R4=2k as the figure1.

Component Selection

Inductor Selection

The ACE752D can utilize small inductors due to its fast 120kHz switching frequency. Typically, a 100μH inductor is recommended for most applications. Larger values of inductance will allow greater output current capability by reducing the inductor ripple current. Increasing the inductance above will also increase size.

The inductor current ripple is typically set for 20% to 40% of the maximum inductor current (I_P). The inductor should have low DCR (series resistance of the windings) to reduce the power losses, and must be able to handle the peak inductor current without saturating. To minimize radiated noise, use a shielded bobbin inductor.

Output and Input Capacitor Selection

Low ESR (equivalent series resistance) capacitors should be used to minimize the output voltage ripple. The parallel of multilayer ceramic and electrolytic capacitors is an excellent choice as they have extremely low ESR and are low cost.

A parallel of 10μF ceramic capacitor and 220μF electrolytic capacitor is sufficient for most applications. Larger values may be used to obtain extremely low output voltage ripple and improve transient response.

Low ESR input capacitors reduce input switching noise and reduce the peak current drawn from the battery. It follows that ceramic capacitors are also a good choice for input decoupling, and should be located as close as possible to the device. A 10μF input capacitor is sufficient for virtually any application.

For all the ceramic capacitors above, X5R and X7R dielectric materials are preferred, for their ability to maintain capacitance over wide voltage and temperature ranges.



ACE752D 120KHz 3.5A Buck DC-DC Converter

Typical Application Circuit

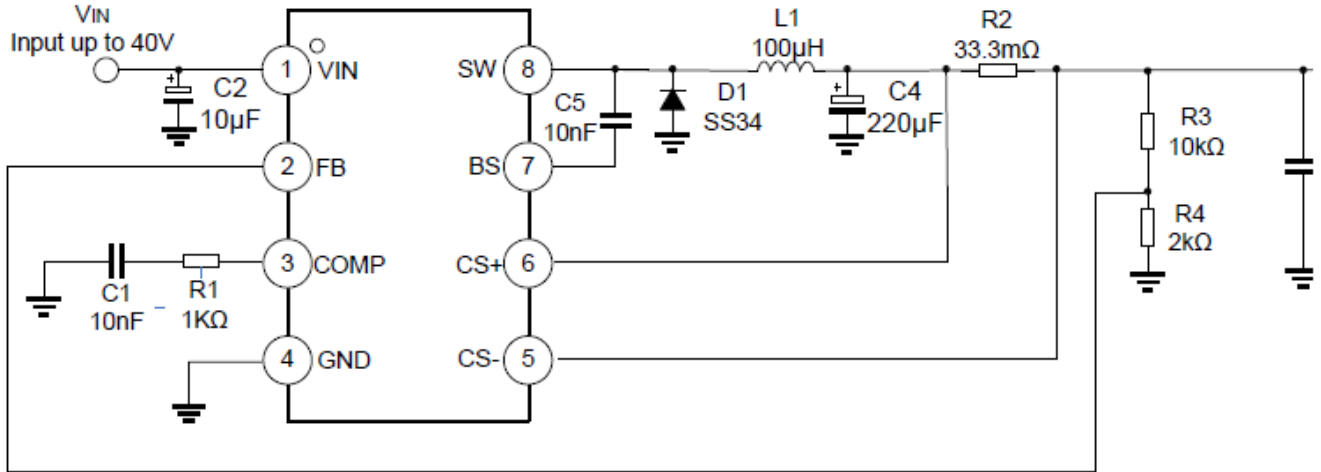

Figure 1. Application Circuit for 5V Output, 2.1A Current Limit

Note:

The circuit and parameters are reference only, please set the parameters of the real application circuit based on the real test.



ACE752D 120KHz 3.5A Buck DC-DC Converter

Packing Information
ESOP-8

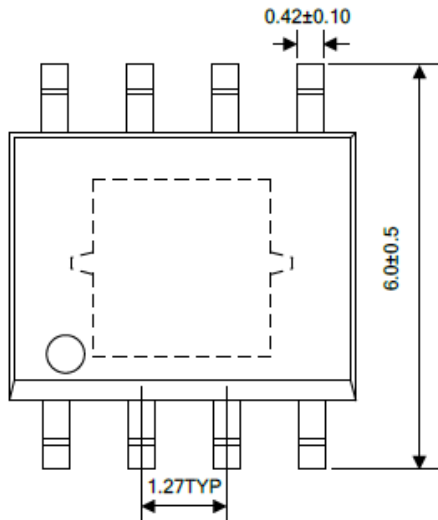

TOP VIEW

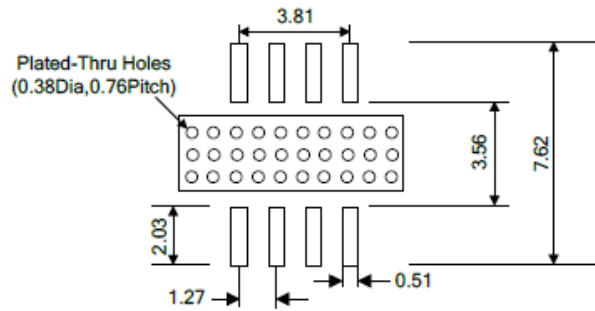

RECOMMENDED LAND PATTERN

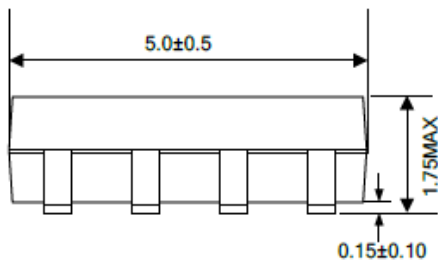

FRONT VIEW

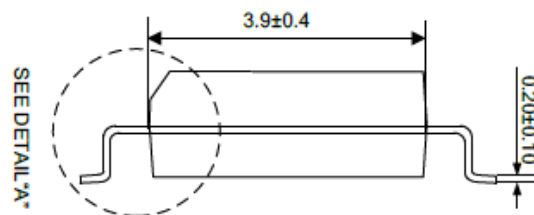

SIDE VIEW

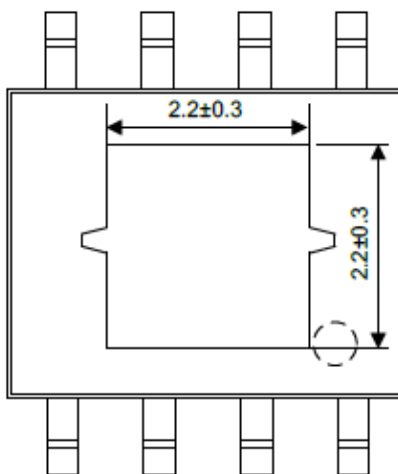

BOTTOM VIEW

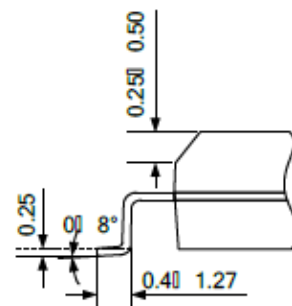

DETAIL 'A'

UNIT: mm

VER 1.1 7



ACE752D 120KHz 3.5A Buck DC-DC Converter

Packing Information
SOP-8

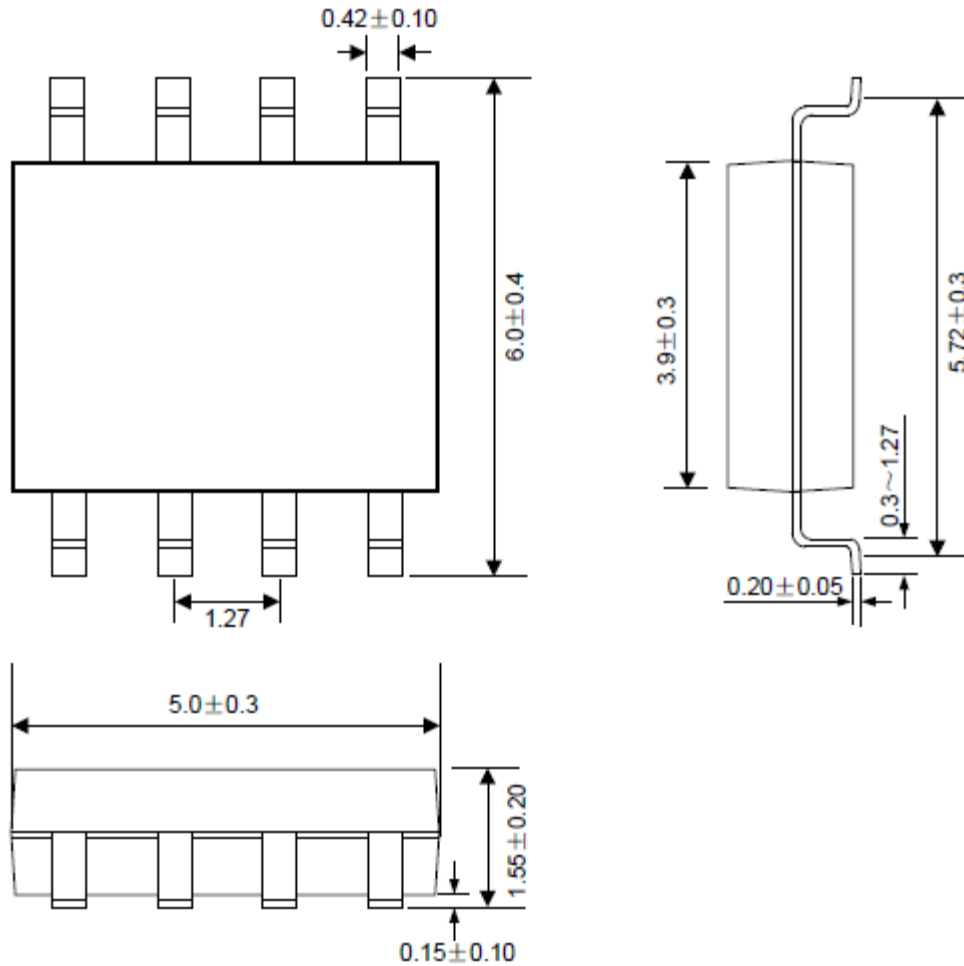

UNIT: mm



ACE752D 120KHz 3.5A Buck DC-DC Converter

Notes

ACE does not assume any responsibility for use as critical components in life support devices or systems without the express written approval of the president and general counsel of ACE Electronics Co., LTD. As sued herein:

1. Life support devices or systems are devices or systems which, (a) are intended for surgical implant into the body, or (b) support or sustain life, and whose failure to perform when properly used in accordance with instructions for use provided in the labeling, can be reasonably expected to result in a significant injury to the user.
2. A critical component is any component of a life support device or system whose failure to perform can be reasonably expected to cause the failure of the life support device or system, or to affect its safety or effectiveness.

ACE Technology Co., LTD.
<http://www.ace-ele.com/>