

# ACFM-7104

Quintplexer for PCS Blocks A–G/Cellular/S-GPS

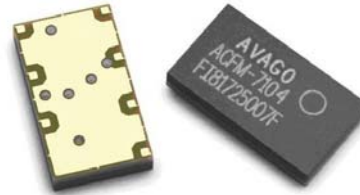

## Data Sheet



### Description

The Avago Technologies' ACFM-7104 is a miniature quintplexer that combines an extended frequency range PCS duplexer (Blocks A-G) with a Cellular duplexer and GPS filter. This device simplifies handset applications that are designed for simultaneous voice service and GPS positioning.

The ACFM-7104 features two antenna connections, one for the duplexers and a separate antenna port for the GPS filter. The ACFM-7104 can be used for single antenna applications by simply connecting both antenna terminals together with a single, external SMT component.

The ACFM-7104 is designed with Avago Technologies' Film Bulk Acoustic Resonator (FBAR) technology. The ACFM-7104 also utilizes Avago Technologies' innovative Microcap bonded-wafer, chip scale packaging technology. This process allows the filters to be assembled in a module with a footprint of only 4 x 7 mm and maximum height of 1.2 mm.

Low Tx Insertion Loss reduces power amplifier current, extending battery life and talk time. The ACFM-7104 enhances receiver sensitivity and dynamic range with low Rx Insertion Loss and high rejection of Tx signals at the Rx ports.

The excellent power handling capability of Avago Technologies' FBAR bulk-mode resonators supports the high Tx output power levels needed in handsets while adding virtually no distortion.

### Functional Block Diagram

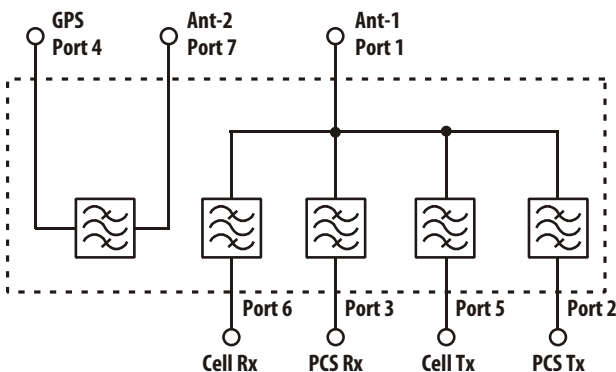

### Features

- Extended PCS frequency range covers Blocks A through G
- Dual/Single Antenna Option
  - Common Antenna connection for PCS and Cell band duplexers
  - Separate GPS Antenna connection
  - Duplexer and GPS antennas can be connected together with an inductor for single antenna applications
- Miniature size
  - 4 x 7 mm footprint
  - 1.2 mm Max Height
- High Power Rating
  - +33 dBm Max Tx Power
- Environmental
  - RoHS Compliant
  - TBBPA Free
  - Halogen Free

### Specifications

- Performance guaranteed –10 to +85°C
- GPS Filter (1574.42–1576.42 MHz)
  - Insertion Loss: 1.7 dB Max, 0.6 dB Typ (25°C)
  - Isolation in PCS: 45 dB Min, Cell Tx: 50 dB Min
- Cellular Duplexer Rx (869 – 894 MHz)
  - Insertion Loss: 3.6 dB Max, 2.1 dB Typ (25°C)
  - Noise Blocking: 40 dB Min
- Cellular Duplexer Tx (824 – 849 MHz)
  - Insertion Loss: 2.9 dB Max, 1.4 dB Typ (25°C)
  - Interferer Blocking: 55 dB Min
- PCS Duplexer Rx (1930.5 – 1994.4 MHz)
  - Insertion Loss: 4.0 dB Max, 1.7 dB Typ (25°C)
  - Noise Blocking: 40 dB Min
- PCS Duplexer Tx (1850.5 – 1914.4 MHz)
  - Insertion Loss: 4.1 dB Max, 1.6 dB Typ (25°C)
  - Interferer Blocking: 53 dB Min

### Applications

- Handsets or data terminals operating in the Cellular and extended PCS frequency bands with simultaneous GPS positioning capability

**ACFM-7104 Electrical Specifications,  $Z_0=50\ \Omega$ ,  $T_C$ <sup>[1][2]</sup> as indicated, Dual Antenna Connection<sup>[4]</sup>**

Symbol	Parameter	Units	- 10°C			+25°C			+85°C		
			Min	Typ <sup>[3]</sup>	Max	Min	Typ <sup>[3]</sup>	Max	Min	Typ <sup>[3]</sup>	Max
<b>GPS Filter Performance</b>											
<b>Antenna–2 Port to GPS Receive Port</b>											
S47	Insertion Loss in GPS Band (L1) (1574.42–1576.42 MHz)	dB			1.6		0.6	1.6			1.7
S47	Insertion Loss Ripple (p-p) in GPS Band	dB					–	0.5			1.0
S44	Return Loss (SWR) of GPS Port in GPS Band	dB	9		(2.1)	9	23	(2.1)	9		(2.1)
S77	Return Loss (SWR) of Antenna–2 Port in GPS Band	dB	9		(2.1)	9	21	(2.1)	9		(2.1)
<b>Isolation – Cellular Transmit Port to GPS Port (Single Antenna)<sup>[5]</sup></b>											
S45	Isolation in Cellular Tx Band (824–849 MHz)	dB	50			50	54		50		
S45	Isolation in GPS Band (1574.42–1576.42 MHz)	dB	40			40	53		40		
<b>Isolation – PCS Transmit Port to GPS Port (Single Antenna)<sup>[5]</sup></b>											
S42	Isolation in PCS Tx Band (1850.5 – 1914.4 MHz)	dB	45			45	49		45		
S42	Isolation in GPS Band (1574.42–1576.42 MHz)	dB	40			40	46		40		
<b>Cellular Duplexer Performance</b>											
<b>Antenna–1 Port to Cellular Receive Port</b>											
S61	Insertion Loss in Rx band (869–894 MHz)	dB			3.6		2.1	3.6			3.6
S61	Insertion Loss Ripple (p-p) in Rx Band	dB			3.4		–	2.5			
S61	Attenuation in Tx band (824–849 MHz)	dB	55			55	59		50		
S61	Attenuation, 0–804 MHz	dB	205			25	36		25		
S61	Attenuation in Tx 2 <sup>nd</sup> harmonic band (1648–1698 MHz)	dB	30			30	59		30		
S61	Attenuation in Tx 3 <sup>rd</sup> harmonic band (2472–2547 MHz)	dB	19			19	48		8		
S66	Return Loss (SWR) of Rx Port in Rx Band (869–894 MHz)	dB	9		(2.1)	9	18	(2.1)	9		(2.1)
S11	Return Loss (SWR) of Antenna–1 Port in Rx Band (869–894 MHz)	dB	9		(2.1)	9	10	(2.1)	9		(2.1)

Notes:

1.  $T_C$  is the case temperature and is defined as the temperature of the underside of the quintplexer where it makes contact with the circuit board.
2. Min/Max specifications are guaranteed at the indicated temperature with the input power to the Tx ports equal to or less than +29 dBm over all Tx frequencies unless otherwise noted.
3. Typical data is the arithmetic mean value of the parameter over its indicated frequency range at the specified temperature. Typical values may vary over time.
4. Unless otherwise noted, specifications are for Dual Antenna connection as shown in Figure 1 and include effect of 5.1 nH inductor and 1.0 pF capacitor added to Port 1 (Ant-1) via simulation.
5. Specifications is for Single Antenna connection as shown in Figure 2 and include effect of 5.1 nH inductor added between Port 1 (Ant-1) and Port 7 (Ant-2) via simulation.

**ACFM-7104 Electrical Specifications,  $Z_0=50\ \Omega$ ,  $T_C$ <sup>[1][2]</sup> as indicated, Dual Antenna Connection<sup>[4]</sup> (continued)**

Symbol	Parameter	Units	- 10°C			+25°C			+85°C		
			Min	Typ <sup>[3]</sup>	Max	Min	Typ <sup>[3]</sup>	Max	Min	Typ <sup>[3]</sup>	Max
<b>Cellular Transmit Port to Antenna-1 Port</b>											
S15	Insertion Loss in Tx band (824-849 MHz)	dB			2.9		1.4	2.9			2.9
S15	Insertion Loss Ripple (p-p) in Tx Band	dB					-	1.5			2.5
S15	Attenuation in Rx band (869-894 MHz)	dB	39			40	64		37		
S15	Attenuation, 0-804 MHz	dB	20			20	39		20		
S15	Attenuation in GPS band (1574.42-1576.42 MHz)	dB	37			37	47		37		
S15	Attenuation in Tx 2 <sup>nd</sup> harmonic band (1648-1698 MHz)	dB	20			20	44		20		
S15	Attenuation in Tx 3 <sup>rd</sup> harmonic band (2472-2547 MHz)	dB	8			8	24		8		
S55	Return Loss (SWR) of Tx Port in Tx band (824-849 MHz)	dB	9		(2.1)	9	13	(2.1)	9		(2.1)
S11	Return Loss (SWR) of Antenna-1 port in Tx Band (824-849 MHz)	dB	9		(2.1)	9	13	(2.1)	9		(2.1)
<b>Isolation, Cellular Transmit Port to Cellular Receive Port</b>											
S65	Isolation, Tx to Rx port in Rx Band (869-894 MHz)	dB	40			40	58		40		
S65	Isolation, Tx to Rx port in Tx Band (824-849 MHz)	dB	55			55	67		55		
<b>PCS Duplexer Performance</b>											
<b>Antenna-1 Port to PCS Receive Port</b>											
S31	Insertion Loss in Rx Band (1930.5-1994.4 MHz)	dB			4.0		1.7	3.6			3.7
S31	Insertion Loss Ripple (p-p) in Rx Band	dB			3.0		-	2.5			
S31	Attenuation in Tx Band (1850.5-1914.4 MHz)	dB	50			50	60		50		
S31	Attenuation 0.03-1770 MHz	dB	20			20	40		20		
S31	Attenuation 2025-3700 MHz	dB	30			30	55		30		
S33	Return Loss (SWR) of Rx Port in Rx Band (1930.5-1994.4 MHz)	dB	9		(2.1)	9	17	(2.1)	9		(2.1)
S11	Return Loss (SWR) of Antenna-1 Port in Rx Band (1930.5-1994.4 MHz)	dB	9		(2.1)	9	18	(2.1)	9		(2.1)

Notes:

- $T_C$  is the case temperature and is defined as the temperature of the underside of the quintplexer where it makes contact with the circuit board.
- Min/Max specifications are guaranteed at the indicated temperature with the input power to the Tx ports equal to or less than +29 dBm over all Tx frequencies unless otherwise noted.
- Typical data is the arithmetic mean value of the parameter over its indicated frequency range at the specified temperature. Typical values may vary over time.
- Unless otherwise noted, specifications are for Dual Antenna connection as shown in Figure 1 and include effect of 5.1 nH inductor and 1.0 pF capacitor added to Port 1 (Ant-1) via simulation.
- Specifications is for Single Antenna connection as shown in Figure 2 and include effect of 5.1 nH inductor added between Port 1 (Ant-1) and Port 7 (Ant-2) via simulation.

**ACFM-7104 Electrical Specifications,  $Z_0=50\ \Omega$ ,  $T_C$ <sup>[1][2]</sup> as indicated, Dual Antenna Connection<sup>[4]</sup> (continued)**

Symbol	Parameter	Units	- 10°C			+25°C			+85°C		
			Min	Typ <sup>[3]</sup>	Max	Min	Typ <sup>[3]</sup>	Max	Min	Typ <sup>[3]</sup>	Max
<b>PCS Transmit Port to Antenna-1 Port</b>											
S12	Insertion Loss in Tx Band (1850.5–1914.4 MHz)	dB			3.1		1.6	3.1			4.1
S12	Insertion Loss Ripple (p-p) in Tx Band	dB					–	1.5			2.5
S12	Attenuation in Rx Band (1930.5–1994.4 MHz)	dB	37			39	60		39		
S12	Attenuation 0.03–1570 MHz	dB	15			15	42		15		
S12	Attenuation in GPS Band (1574.42–1576.42 MHz)	dB	37			37	40		37		
S12	Attenuation 1580 – 1700 MHz	dB	25			25	42		25		
S12	Attenuation in Tx 2 <sup>nd</sup> harmonic band (3701–3829 MHz)	dB	10			10	19		10		
S12	Attenuation in Tx 3 <sup>rd</sup> harmonic band (5551.5–5743.5 MHz)	dB	8			8	24		8		
S22	Return Loss (SWR) of Tx Port in Tx band (1850.5–1914.4 MHz)	dB	9.5		(2.0)	9.5	13	(2.0)	9.5		(2.0)
S11	Return Loss (SWR) of Antenna-1 port in Tx Band (1850.5–1914.4 MHz)	dB	9		(2.1)	9	13	(2.1)	9		(2.1)
<b>Isolation, PCS Transmit Port to PCS Receive Port</b>											
S32	Isolation, Tx to Rx port in Rx Band (1930.5–1994.4 MHz)	dB	40			40	51		40		
S32	Isolation, Tx to Rx port in Tx Band (1850.5–1914.4 MHz)	dB	53			53	64		53		

Notes:

1.  $T_C$  is the case temperature and is defined as the temperature of the underside of the quintplexer where it makes contact with the circuit board.
2. Min/Max specifications are guaranteed at the indicated temperature with the input power to the Tx ports equal to or less than +29 dBm over all Tx frequencies unless otherwise noted.
3. Typical data is the arithmetic mean value of the parameter over its indicated frequency range at the specified temperature. Typical values may vary over time.
4. Unless otherwise noted, specifications are for Dual Antenna connection as shown in Figure 1 and include effect of 5.1 nH inductor and 1.0 pF capacitor added to Port 1 (Ant-1) via simulation.
5. Specifications is for Single Antenna connection as shown in Figure 2 and include effect of 5.1 nH inductor added between Port 1 (Ant-1) and Port 7 (Ant-2) via simulation.

## Absolute Maximum Ratings<sup>[1]</sup>

Parameter	Unit	Value
Storage temperature	°C	-65 to +125
Maximum RF Input Power to Tx Ports	dBm	+33

## Maximum Recommended Operating Conditions<sup>[2]</sup>

Parameter	Unit	Value
Operating temperature, $T_c$ <sup>[3]</sup> , Tx Power $\leq$ 29 dBm	°C	-40 to +100
Operating temperature, $T_c$ <sup>[3]</sup> , Tx Power $\leq$ 30 dBm	°C	-40 to +85

Notes:

1. Operation in excess of any one of these conditions may result in permanent damage to the device.
2. The device will function over the recommended range without degradation in reliability or permanent change in performance, but is not guaranteed to meet electrical specifications.
3.  $T_c$  is defined as case temperature, the temperature of the bottom mounting surface of the quadplexer where it makes contact with the circuit board.

## Applications Information

The ACFM-7104 quintplexer has two antenna connections, one common to the Cellular and PCS Band duplexers, and a separate antenna for the GPS filter.

### Dual Antenna Operation

For applications in which a separate GPS antenna is preferred, the ACFM-7104 can be connected as shown in Figure 1.

A series-L, shunt-C network is used to match the impedance of the Ant-1 port (duplexers) to the phone antenna. A nominal inductance value of 5.1 nH and capacitance of 1.0 pF matches the Ant-1 port to 50 ohms.

The GPS antenna (Ant-2) is internally matched to 50 ohms and needs no external components.

### Single Antenna Operation

Optionally, if single antenna operation is required, the Ant-1 and Ant-2 ports of the ACFM-7104 can be connected together as in Figure 2.

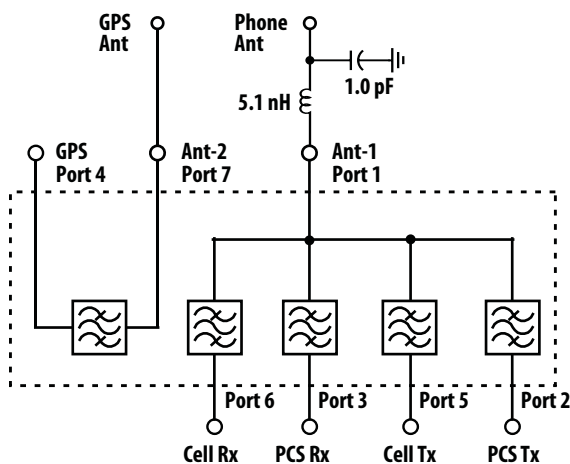

Figure 1. Dual Antenna Application

A single 5.1 nH inductor connected between Ant-1 and Ant-2 is all that is required to match both antenna ports to a common 50-ohm antenna.

### Matching Components

The L and C values shown here were selected to match the ACFM-7104 to 50 ohms. These values should be considered to be nominal. Since every application is different, these nominal values should be adjusted to provide the best impedance match for the user's particular circuit board, performance requirements, and interface to related components.

The L and C matching components should be located in close proximity to the quintplexer as shown in the recommended PCB layouts.

For both antenna configurations, the maximum variation for the matching components should be  $\pm 5\%$  for the inductor and  $\pm 0.2$  pF for the capacitor. The inductor should be of the high Q type (e.g., Murata LQW15AN5N1D00D).

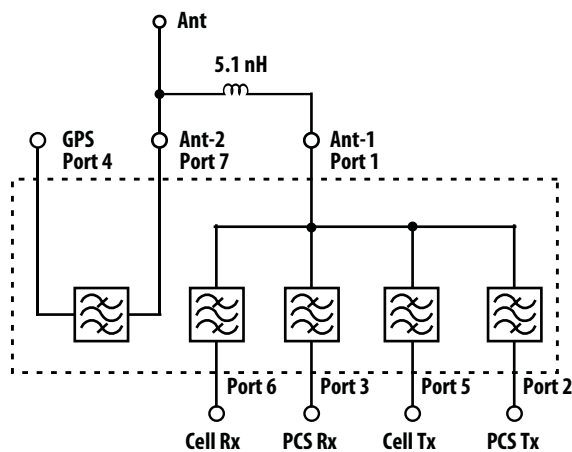

Figure 2. Single Antenna Application.

**ACFM-7104 Typical Performance at  $T_c = 25^\circ\text{C}$**

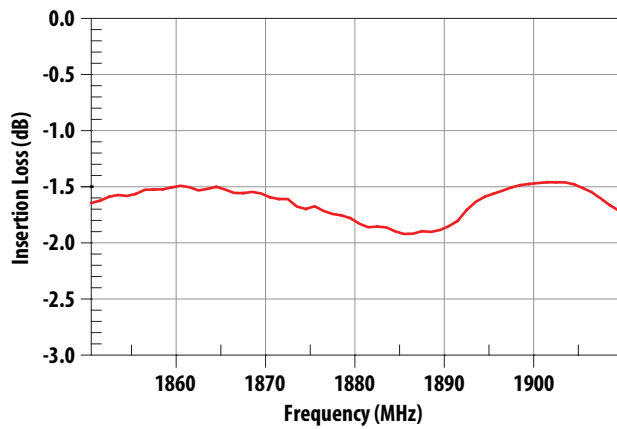

Figure 3. PCS Tx Band Insertion Loss. (Dual Antenna, Note1).

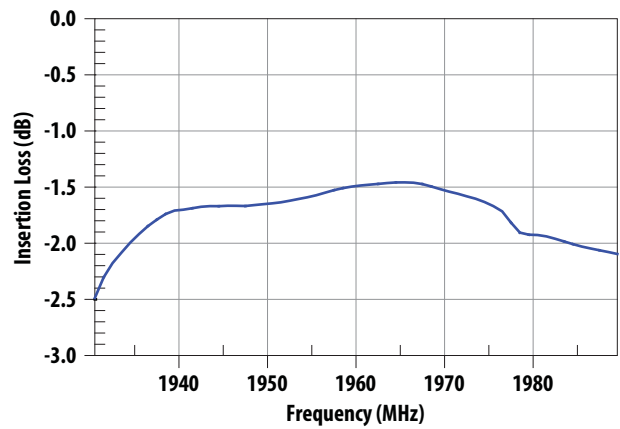

Figure 4. PCS Rx Band Insertion Loss. (Dual Antenna, Note1).

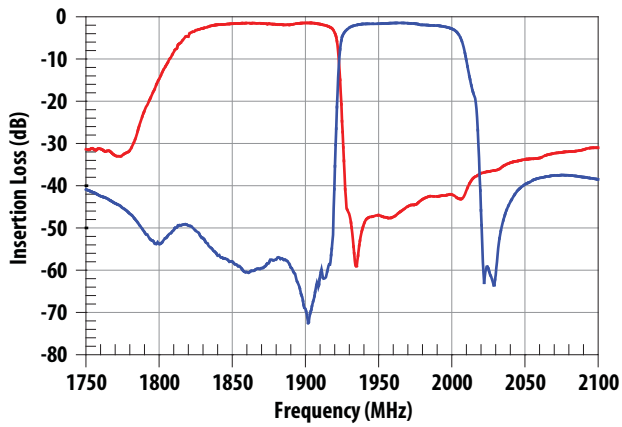

Figure 5. PCS Tx Rejection in Rx Band and Rx Rejection in Tx Band. (Dual Antenna, Note1).

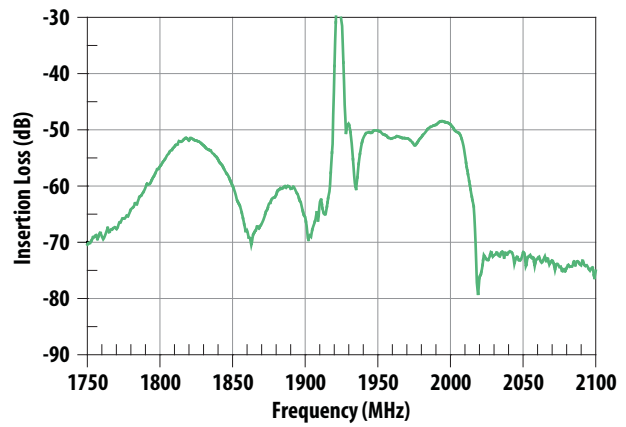

Figure 6. PCS Tx-Rx Isolation. (Dual Antenna, Note1).

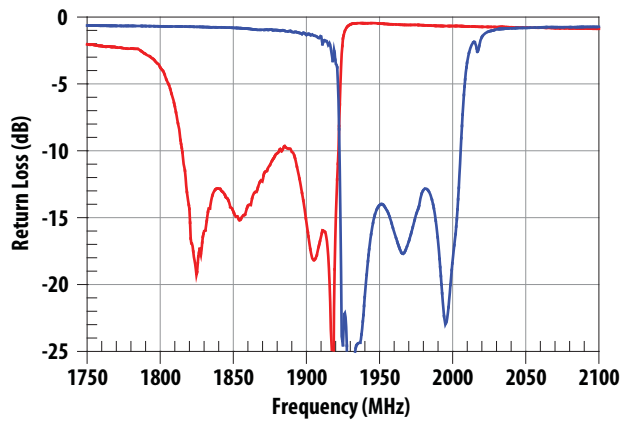

Figure 7. PCS Tx and Rx Port Return Loss. (Dual Antenna, Note1).

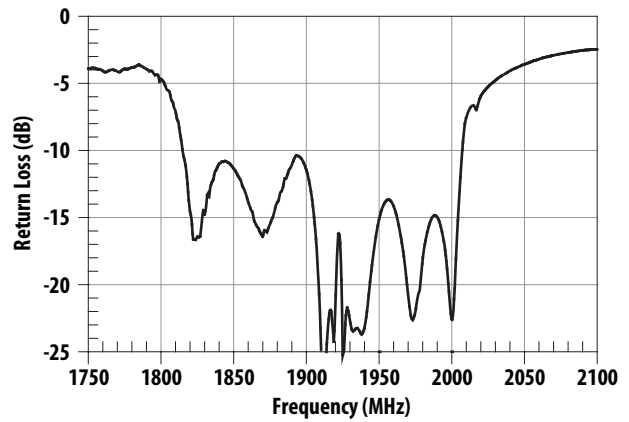

Figure 8. PCS Antenna Port Return Loss. (Dual Antenna, Note1).

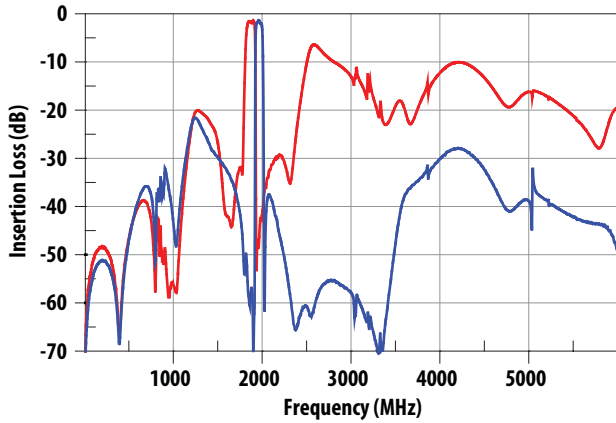

Figure 9. PCS Tx-Ant and Ant-Rx Wideband Insertion Loss. (Dual Antenna, Note1).

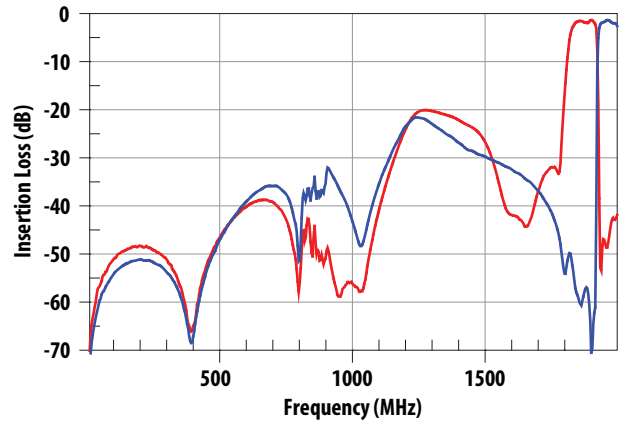

Figure 10. PCS Tx-Ant and Ant-Rx Low Frequency Insertion Loss. (Dual Antenna, Note1).

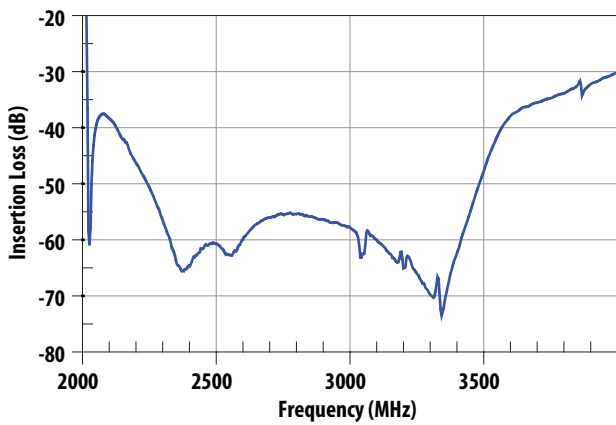

Figure 11. PCS Ant-Rx Rejection, 2000-4000 MHz. (Dual Antenna, Note1).

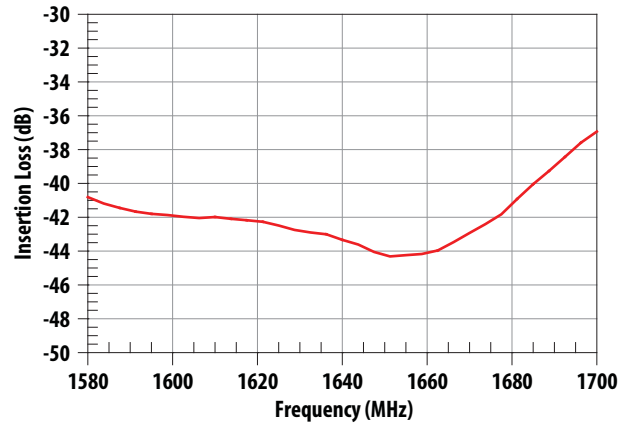

Figure 12. PCS Ant-Tx Rejection, 1580-1700 MHz. (Dual Antenna, Note1).

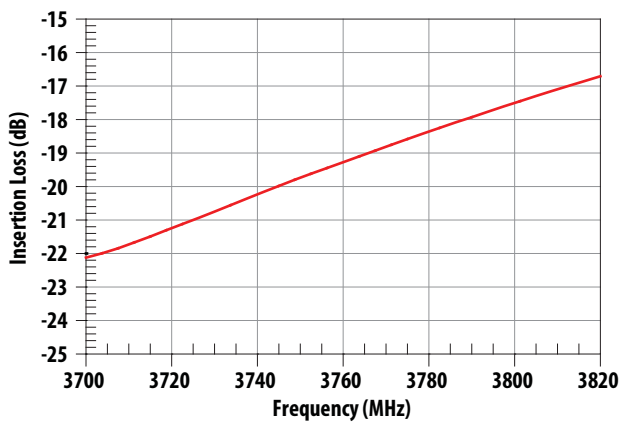

Figure 13. PCS Tx-Ant Rejection at Tx Second Harmonic. (Dual Antenna, Note1).

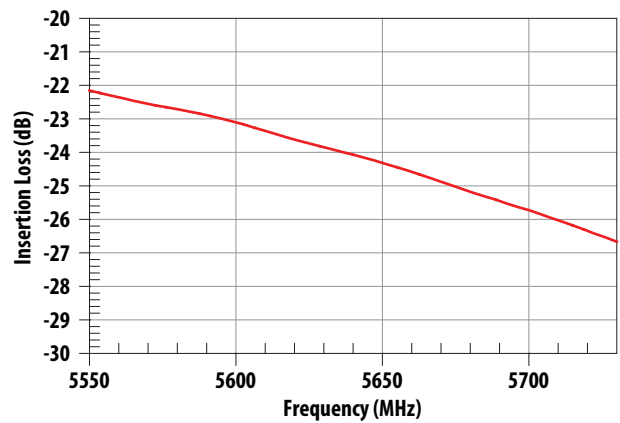

Figure 14. PCS Ant-Tx Rejection at Tx Third Harmonic. (Dual Antenna, Note1).

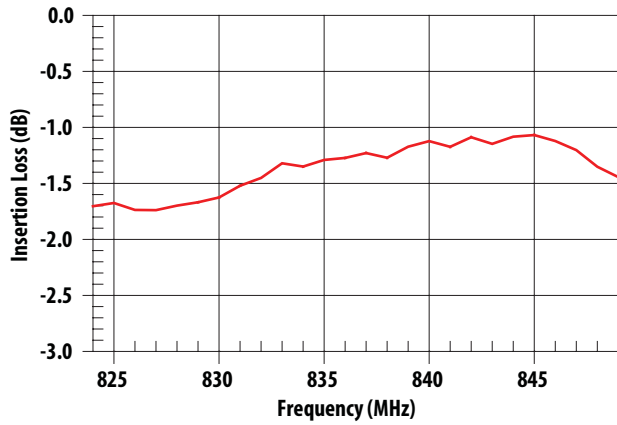

Figure 15. Cellular Tx Insertion Loss. (Dual Antenna, Note1).

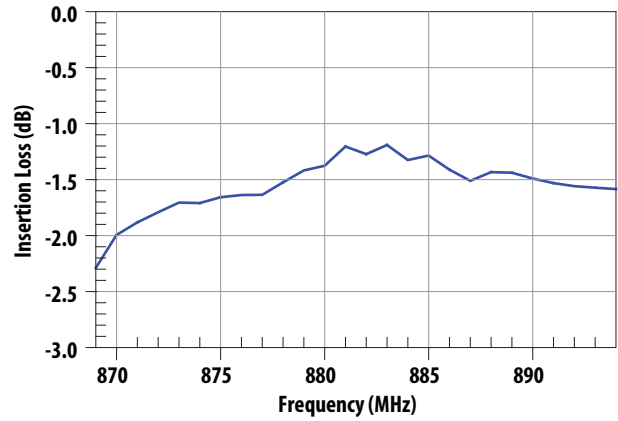

Figure 16. Cellular Rx Insertion Loss. (Dual Antenna, Note1).

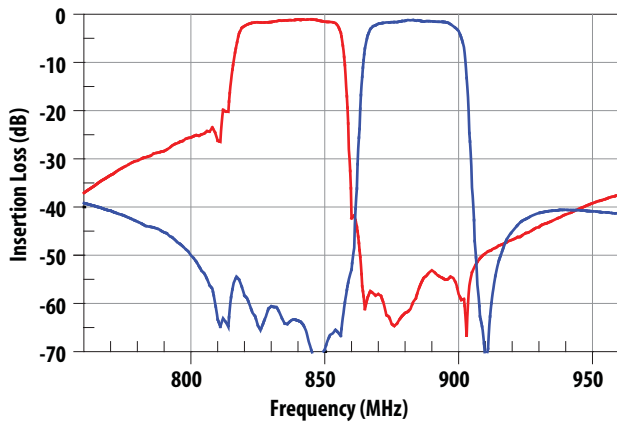

Figure 17. Cellular Tx Rejection in Rx Band and Rx Rejection in Tx Band. (Dual Antenna, Note1).

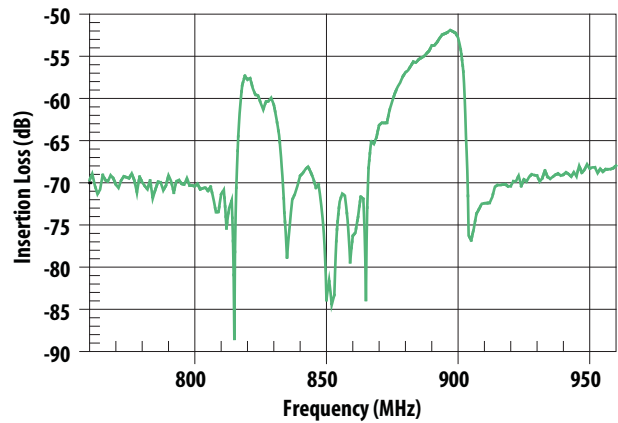

Figure 18. Cellular Tx-Rx Isolation. (Dual Antenna, Note1).

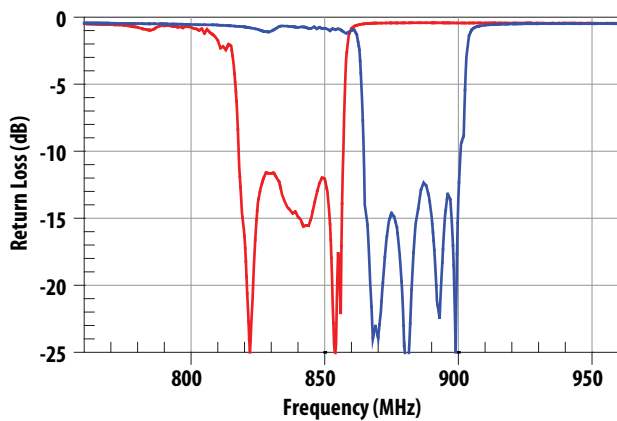

Figure 19. Cellular Tx and Rx Return Loss. (Dual Antenna, Note1).

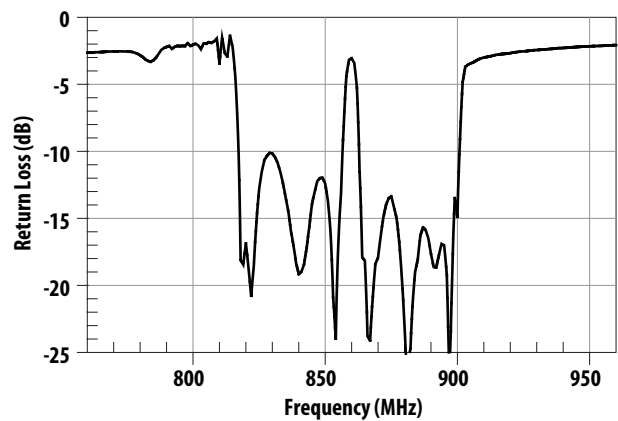

Figure 20. Cellular Band Antenna Return Loss. (Dual Antenna, Note1).



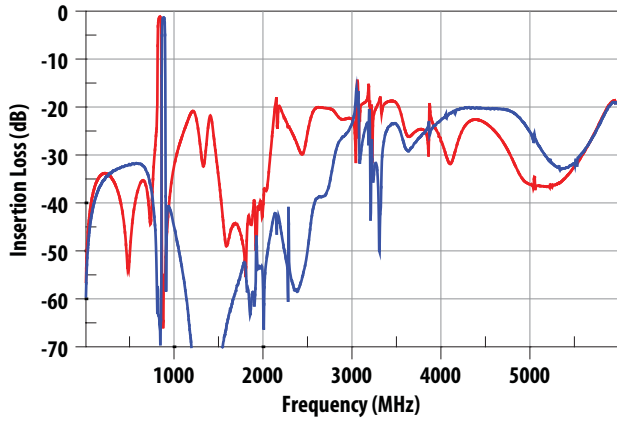

Figure 21. Cellular Tx-Ant and Ant-Rx Wideband Insertion Loss. (Dual Antenna, Note1).

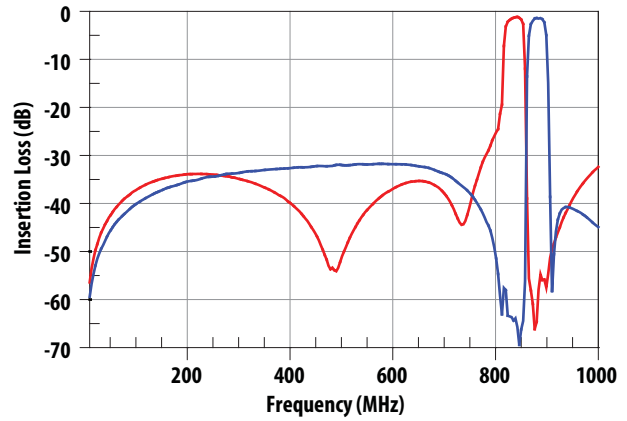

Figure 22. Cellular Tx-Ant and Ant-Rx Low Frequency Insertion Loss. (Dual Antenna, Note1).

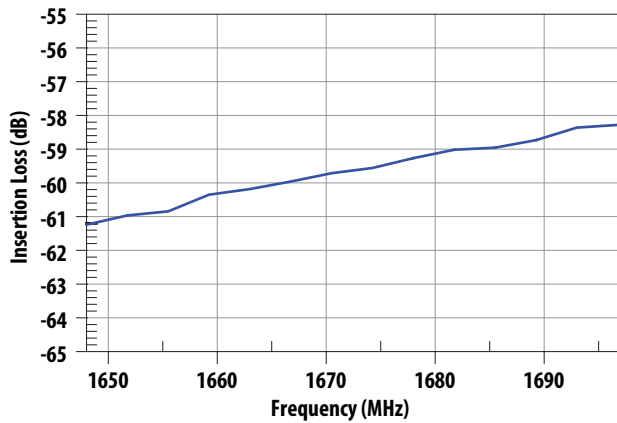

Figure 23. Cellular Ant-Rx Rejection at Tx Second Harmonic. (Dual Antenna, Note1).

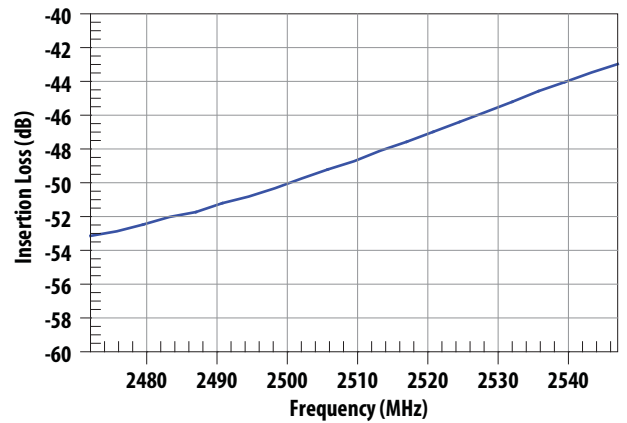

Figure 24. Cellular Ant-Rx Rejection at Tx Third Harmonic. (Dual Antenna, Note1).

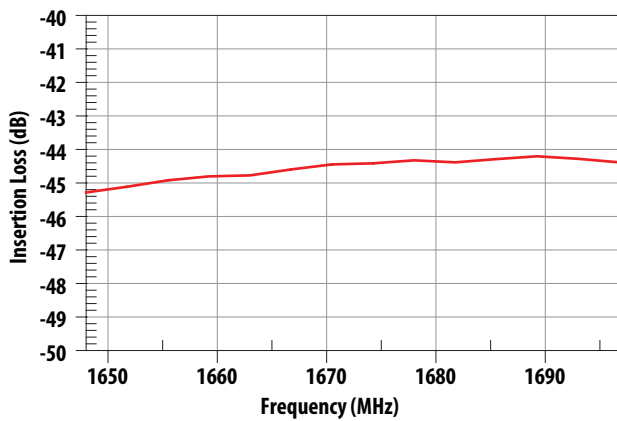

Figure 25. Cellular Tx-Ant Rejection at Tx Second Harmonic. (Dual Antenna, Note1).

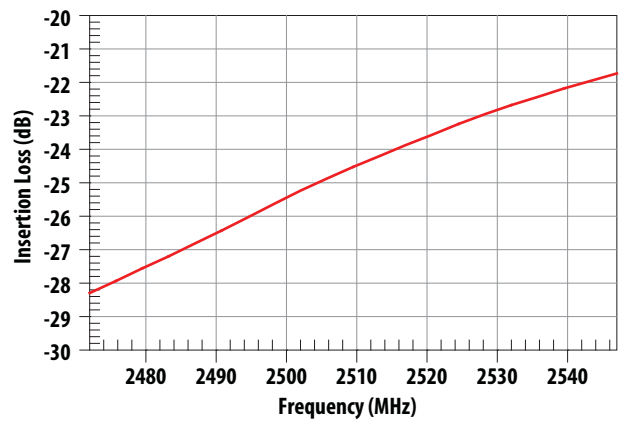

Figure 26. Cellular Tx-Ant Rejection at Tx Third Harmonic. (Dual Antenna, Note1).

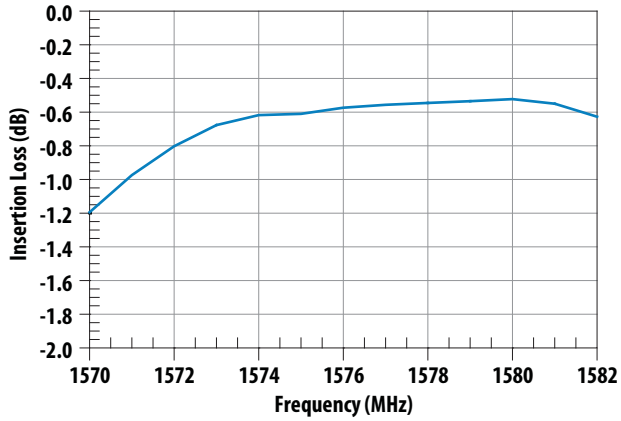

Figure 27. Ant-GPS Insertion Loss. (Dual Antenna, Note1)

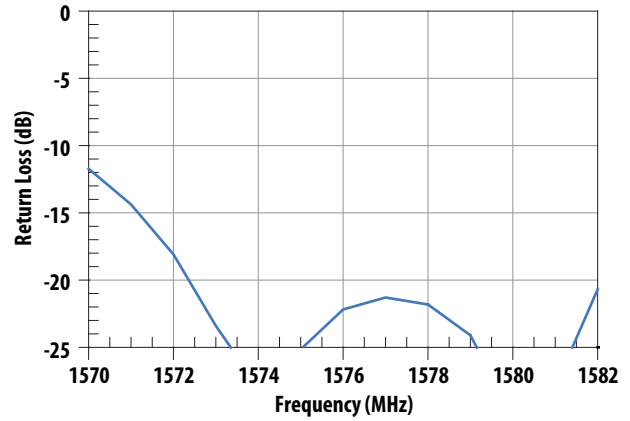

Figure 28. GPS Port Return Loss. (Dual Antenna, Note1).

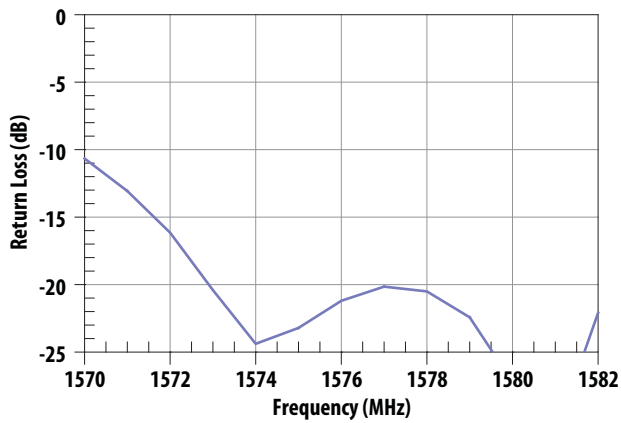

Figure 29. Antenna Port Return Loss in GPS Band. (Dual Antenna, Note1).

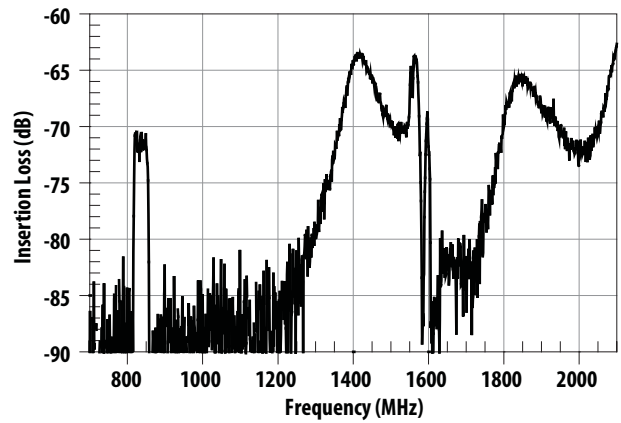

Figure 30. Cellular Tx Port to GPS Port Isolation (Dual Antenna, Note1).

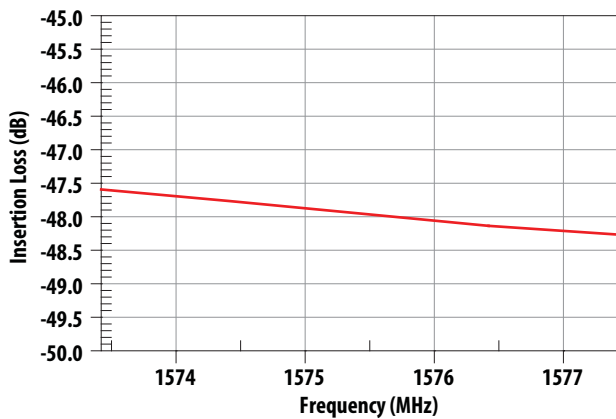

Figure 31. Cellular Tx-Ant, GPS Band Rejection. (Dual Antenna, Note1).

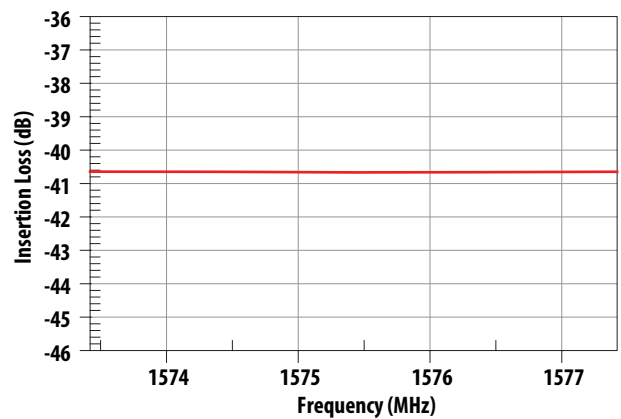

Figure 32. PCS Tx-Ant, GPS Band Rejection.(Dual Antenna, Note1).

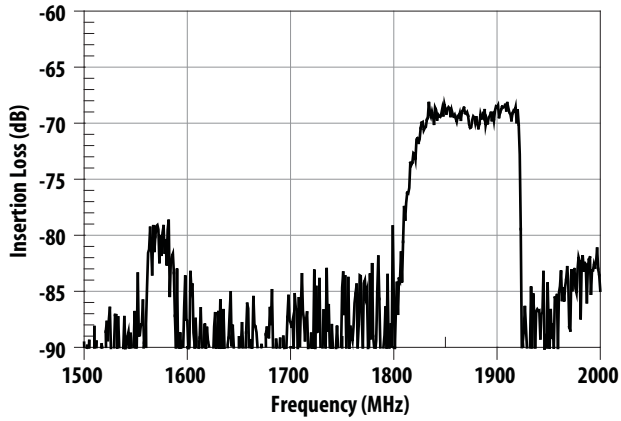

Figure 33. PCS Tx Port to GPS Port Isolation (Dual Antenna, Note1).

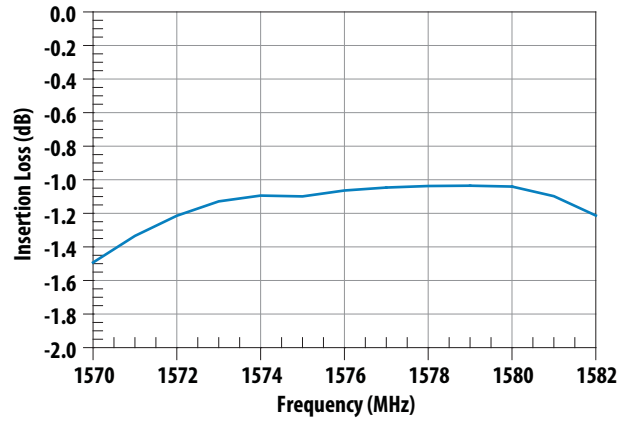

Figure 34. GPS Port Insertion Loss (Single Antenna, Note2).

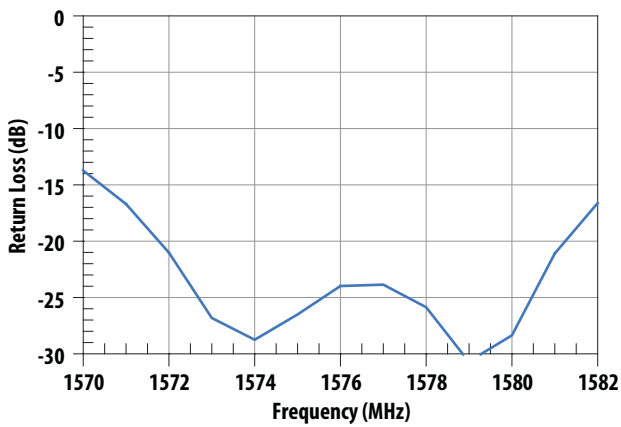

Figure 35. GPS Port Return Loss (Single Antenna, Note2).

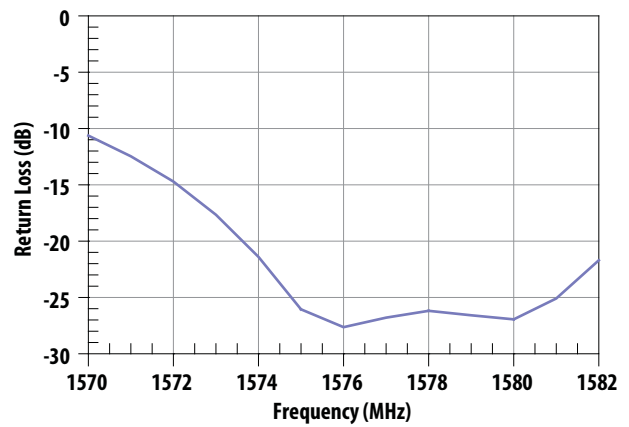

Figure 36. Ant Port RL in GPS Band (Single Antenna, Note2).

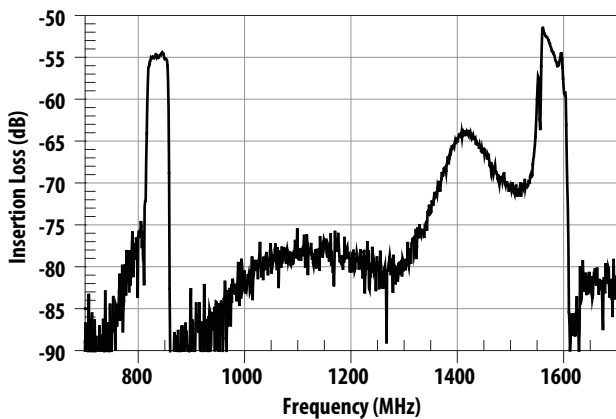

Figure 37. Cell Tx Port to GPS Port Isolation (Single Antenna, Note2).

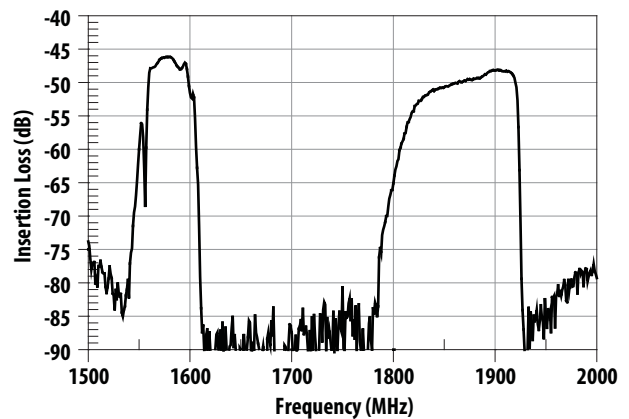

Figure 38. PCS Tx Port to GPS Port Isolation (Single Antenna, Note2).

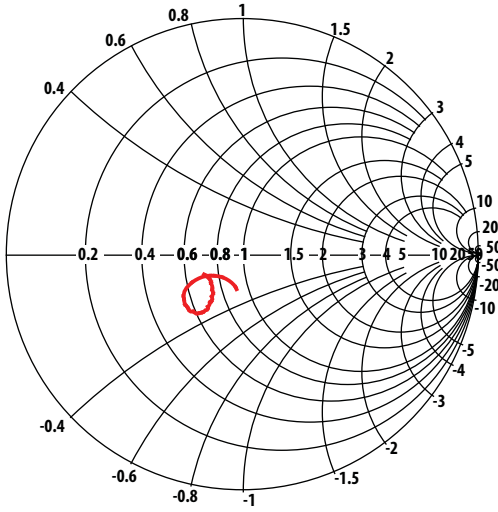

Figure 39. PCS Tx Port Impedance in Tx Band. (Dual Antenna, Note1).

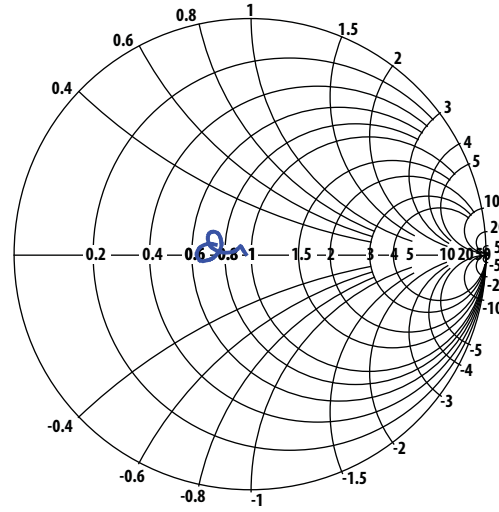

Figure 40. PCS Rx Port Impedance in Rx Band. (Dual Antenna, Note1).

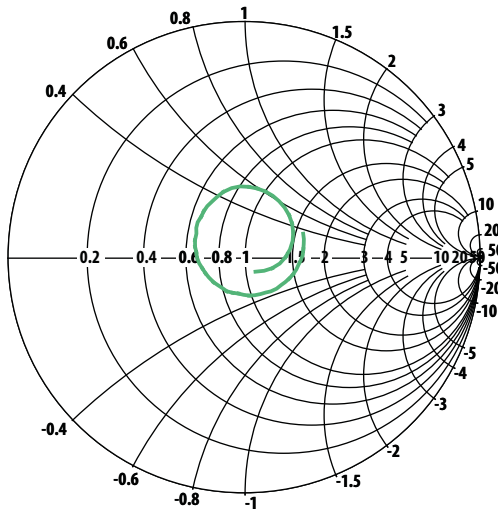

Figure 41. PCS Ant Port Impedance in Tx Band. (Dual Antenna, Note1).

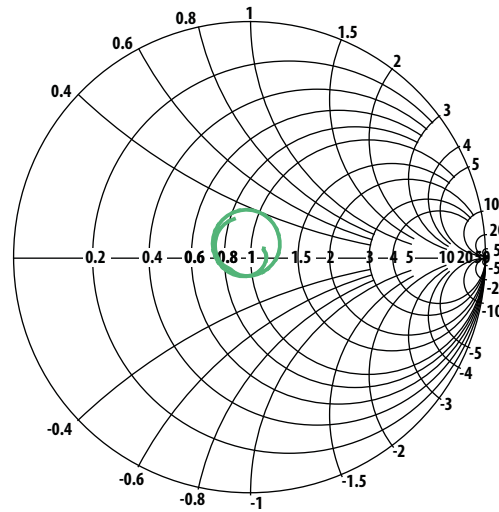

Figure 42. PCS Ant Port Impedance in Rx Band. (Dual Antenna, Note1).

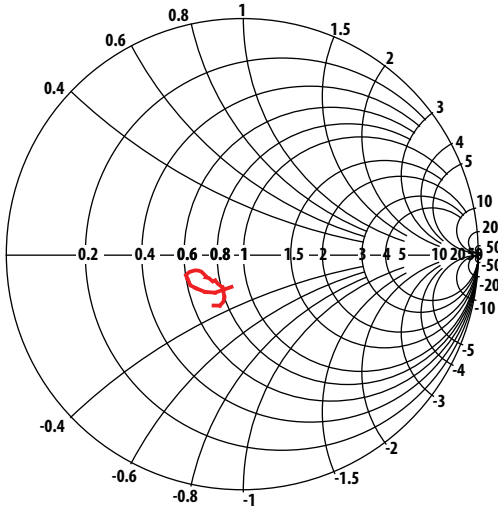

Figure 43. Cellular Tx Port Impedance in Tx Band. (Dual Antenna, Note1).

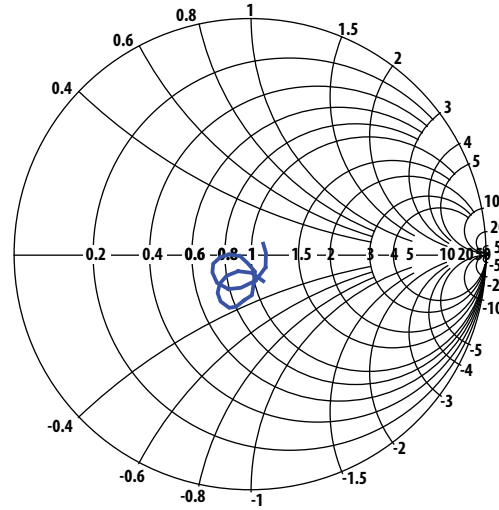

Figure 44. Cellular Rx Port Impedance in Rx Band. (Dual Antenna, Note1).

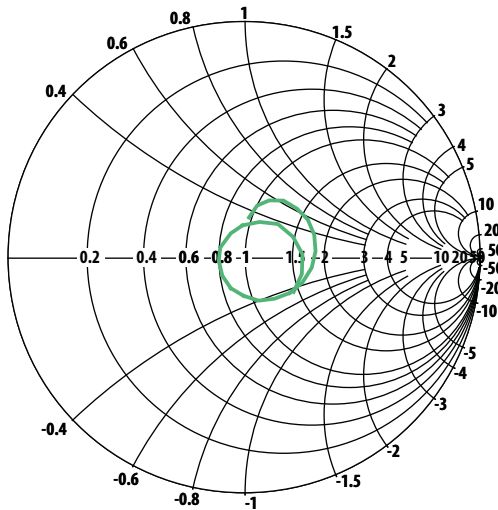

Figure 45. Cellular Ant Port Impedance in Tx Band. (Dual Antenna, Note1).

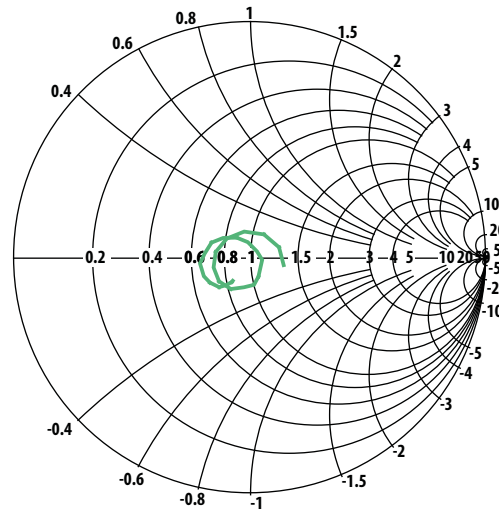
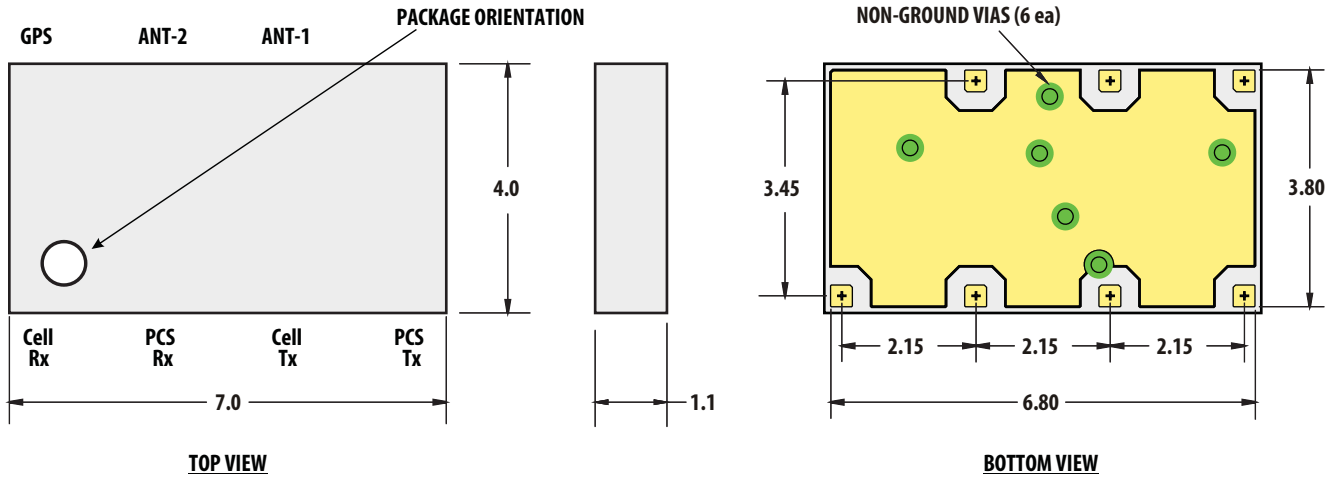

Figure 46. Cellular Ant Port Impedance in Rx Band. (Dual Antenna, Note1).

Notes:

1. Dual Antenna connection as shown in Figure 1. Data measured with  $Z_0=50 \Omega$  for all ports; performance shown includes effect of 5.1 nH inductor and 1.0 pF capacitor added to Port 1 (Ant-1) via simulation.
2. Single Antenna connection as shown in Figure 2. Data measured with  $Z_0=50 \Omega$  for all ports; performance shown includes effect of 5.1 nH inductor added to Port 1 (Ant-1) and Port 7 (Ant-2) via simulation.



- Notes:
1. Dimensions in mm
  2. Tolerance:  $X.X \pm 0.1$ ,  $X.XX \pm 0.05$
  3. Max OD:  $4.1 \times 7.1 \times 1.2$  mm
  4. IO pads (7 ea),  $0.35 \times 0.35$ , pad to ground plane spacing = 0.03
  5. Non-ground vias (6 ea) shown for reference only; covered with  $0.35 \text{ } \varnothing$  solder mask  
Note: PCB metal on mother board under non-ground vias does not need to be voided
  6. Contact areas are gold plated

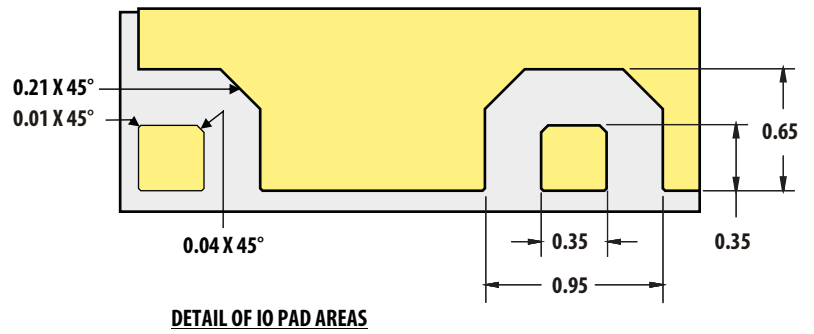

Figure 47. Package Outline Drawing.

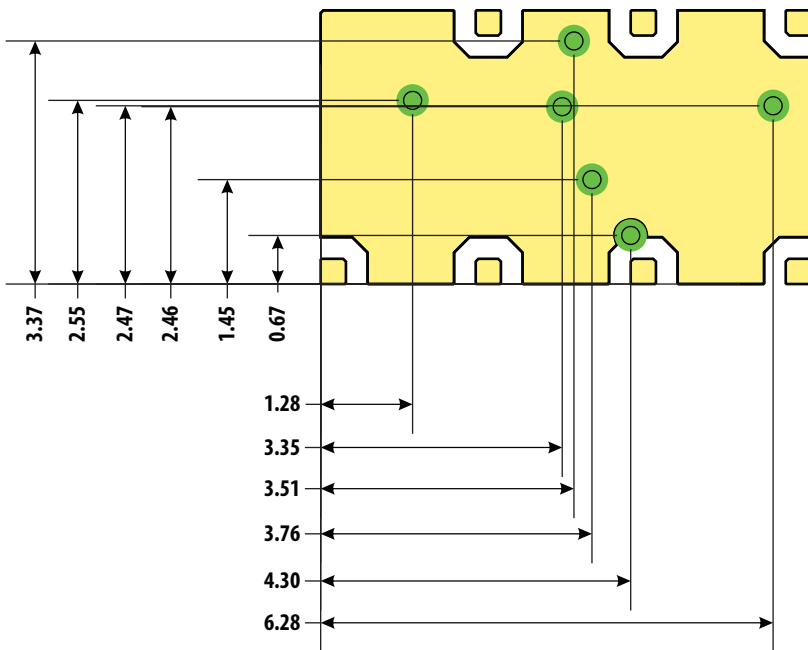
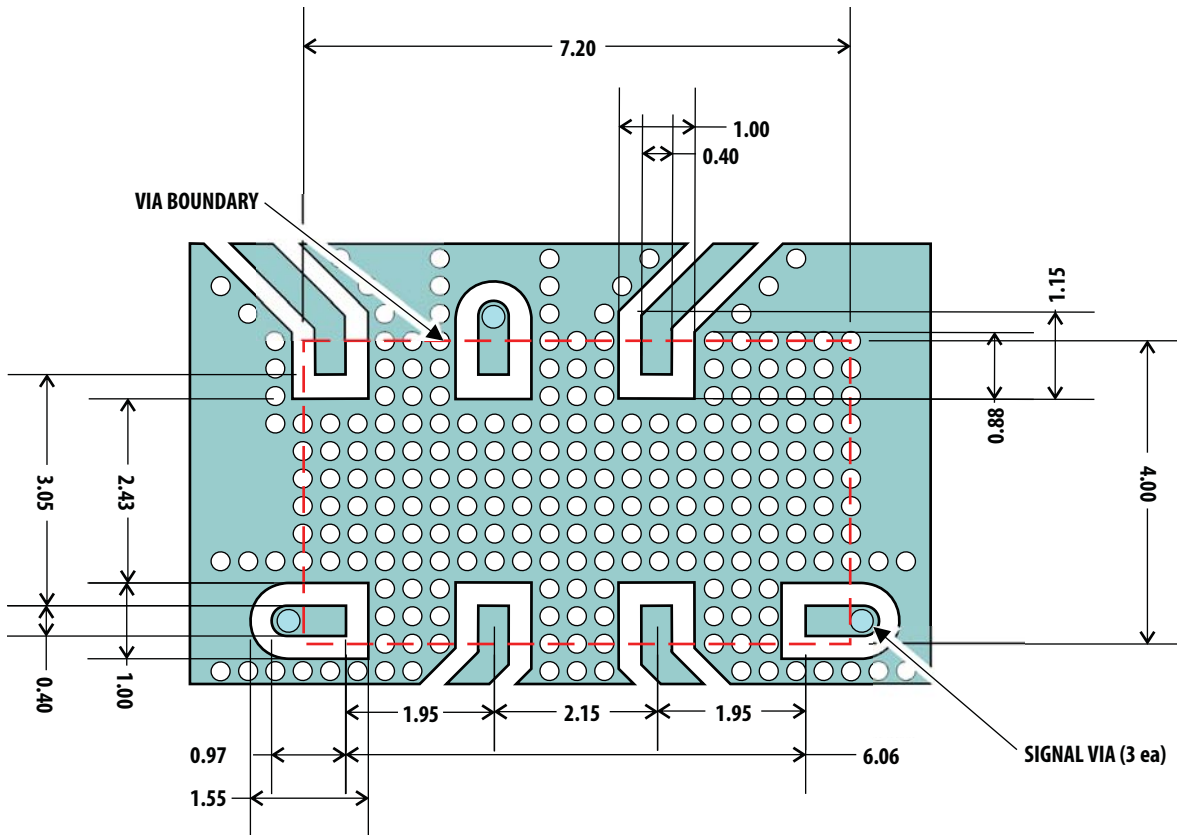

Figure 48. Locations of Non-Ground (Signal) Vias.



Notes:

1. Dimensions in mm
2. I/O pattern centered on device location
3. I/O connections are CPW; dimensions adjusted so  $Z_0 = 50$  ohms
4. Via Boundary rectangle 7.20 x 4.00, centered on device location
5. Ground vias are  $\varnothing 0.25$ , aligned to 0.36 x 0.36 grid
6. Ground vias positioned for optimum RF performance, port-to-port isolation, and device heat sinking
7. Optional: Signal vias (3 ea) are  $\varnothing 0.30$  and feed through to bottom buried metal pattern for ANT-2, Cell-Rx, and PCS-Tx connections
8. Length of lines extending from all ports should be minimized to maintain port-to-port isolation
9. Ant-1, GPS lines and PCS-Rx, Cell-Tx lines should be orthogonal to maintain port-to-port isolation

**Figure 49. Suggested PCB Land Pattern for Dual Antenna Connection (top view).**

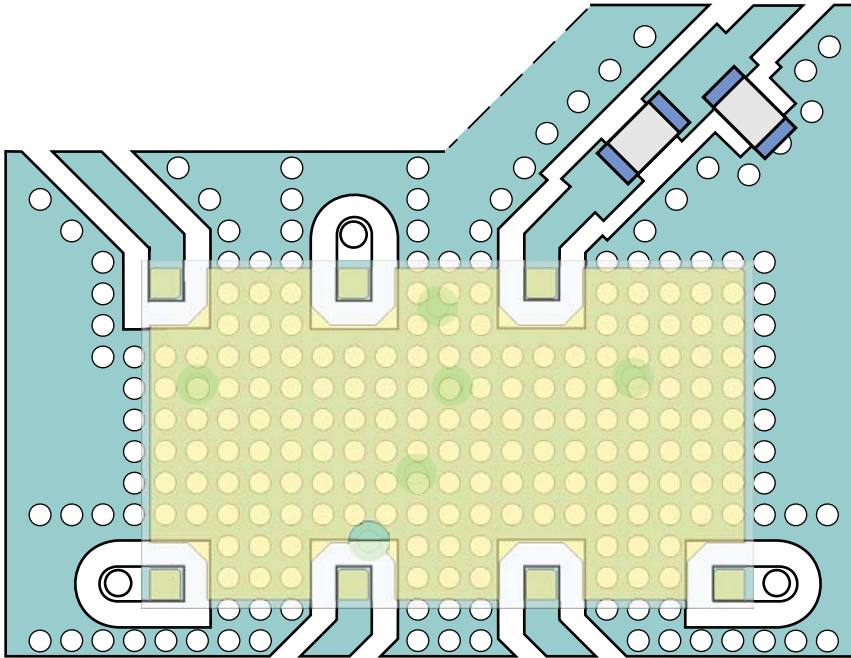

Notes:

1. Dimensions and detail follow same general schema as Figure 41.
2. Includes provision for 0402 size matching components for Ant-1.
3. Suggested I/O connections for Ant-2, Cell-Rx, and PCS-Tx are preferably located on a buried metal layer to maintain best isolation.

**Figure 50. Suggested PCB Layout for Dual Antenna Connection (top view).**

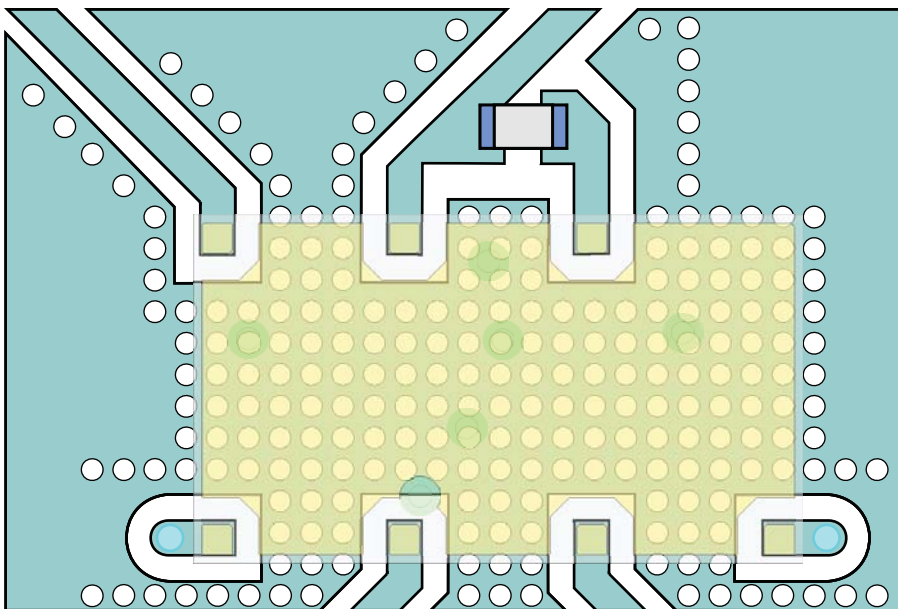

Notes:

1. Dimensions and detail follow same general schema as Figure 41.
2. Includes provision for 0402 size matching inductor to connect Ant-1 and Ant-2.
3. Suggested I/O connections for Cell-Rx, and PCS-Tx are preferably located on a buried metal layer to maintain best isolation.

**Figure 51. Suggested PCB Layout for Single Antenna Connection (top view).**





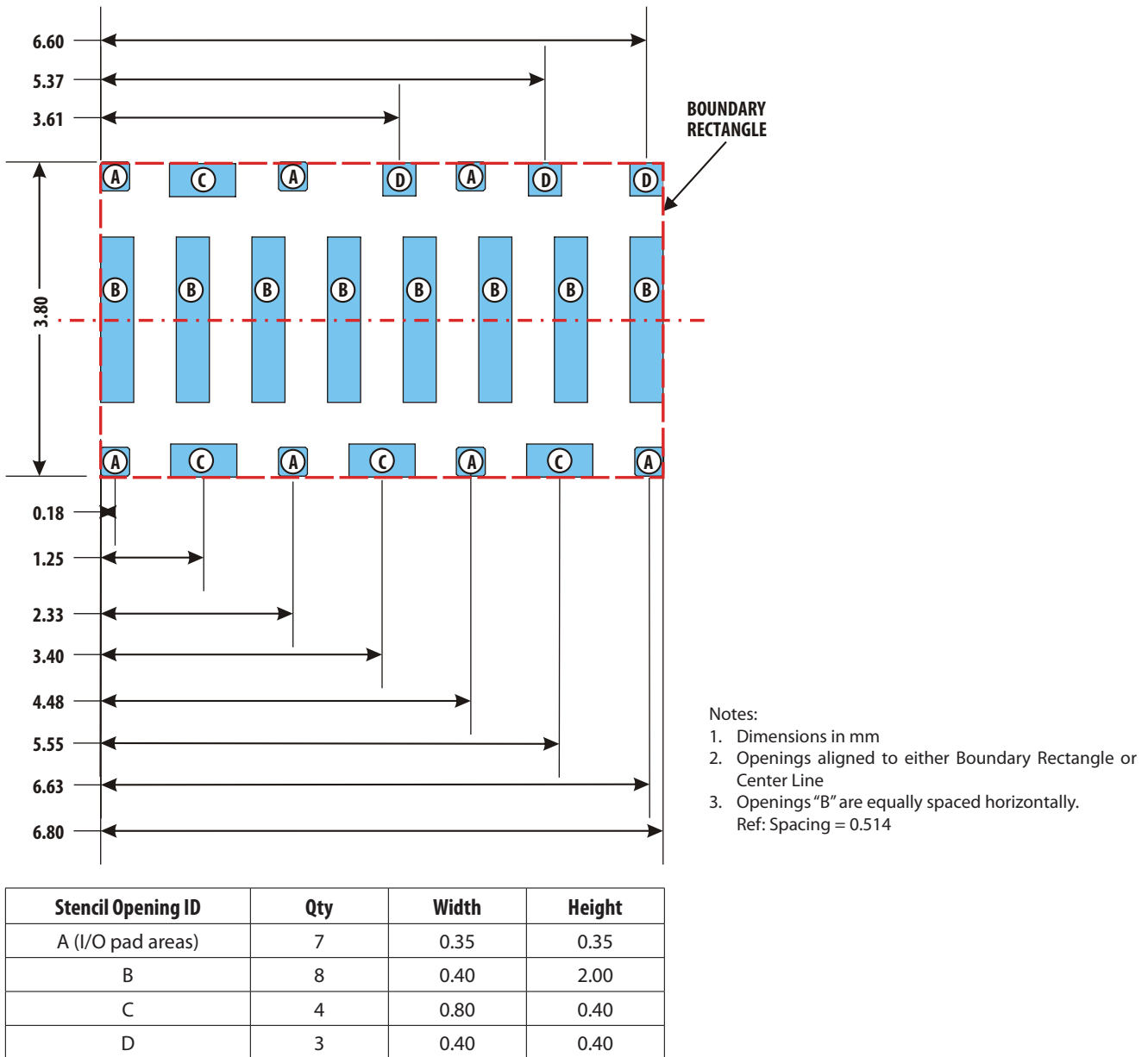

Figure 54. Recommended Solder Stencil (top view).

The I/O pad openings ("A") in the recommended solder stencil are the same size as the I/O pad metal patterns on the ACFM-7104.

The stencil pattern for the large ground pad area is divided into smaller openings ("B" through "D") for the purpose of reducing the volume of solder paste. The use of smaller apertures reduces risk of solder voiding as well as preventing the device from "floating" during reflow.

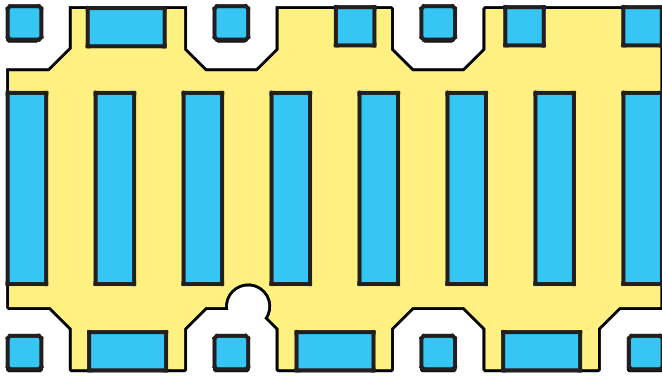

Figure 55. Solder Stencil Superposed on ACFM-7104 Bottom Metal Pattern. (top view)

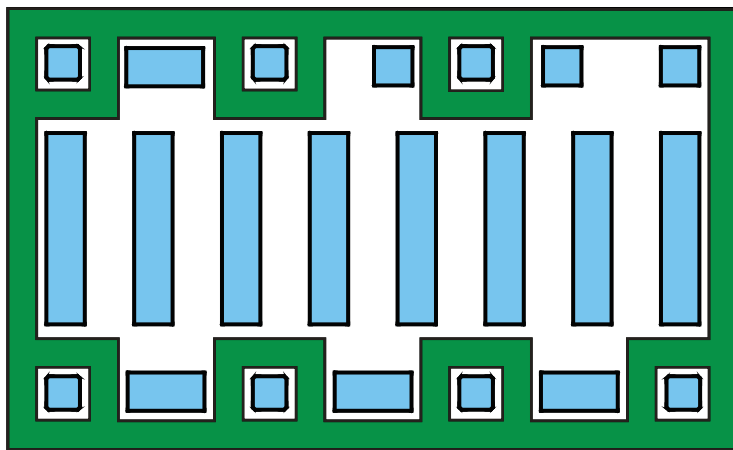

Figure 56. Solder Mask Superposed on Solder Stencil. (top view)

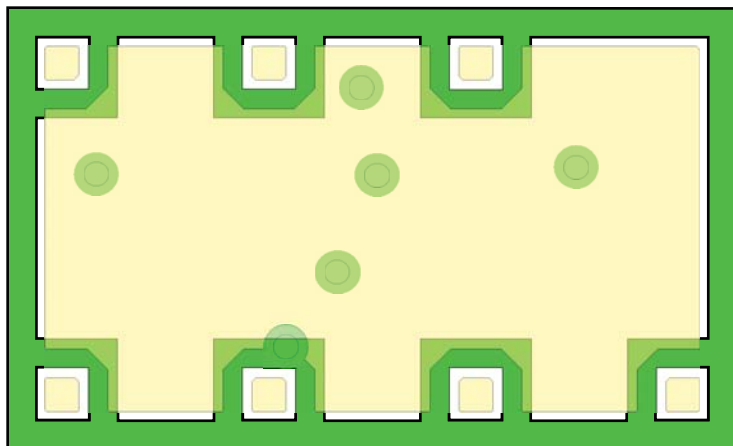

Figure 57. Solder Mask Superposed on ACFM-7104 Bottom Metal Pattern. (top view)

## Package Moisture Sensitivity

Feature	Test Method	Performance
Moisture Sensitivity Level (MSL) at 260°C	J-STD-20C	Level 3

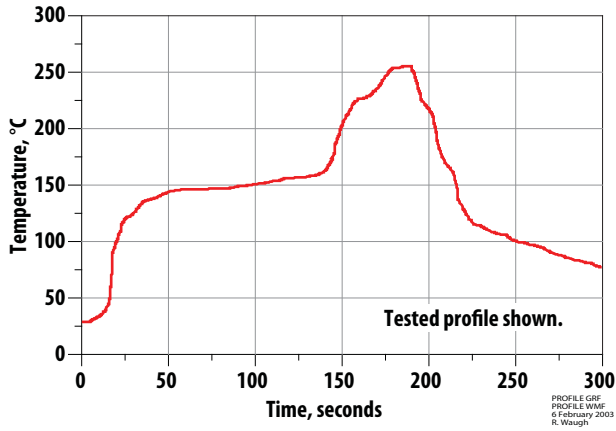

Figure 58. Verified SMT Solder Profile.

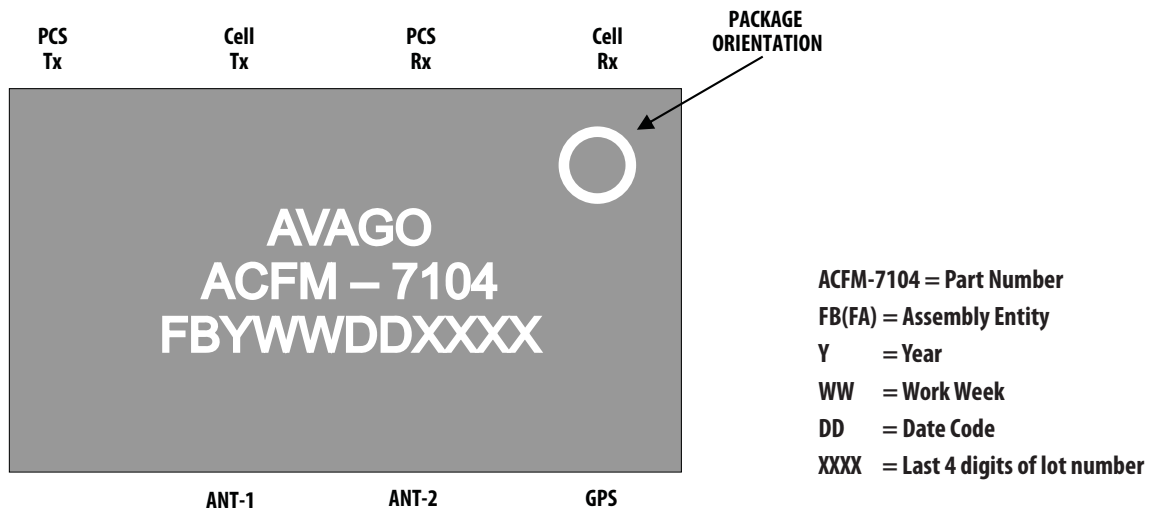

Figure 59. Package Marking

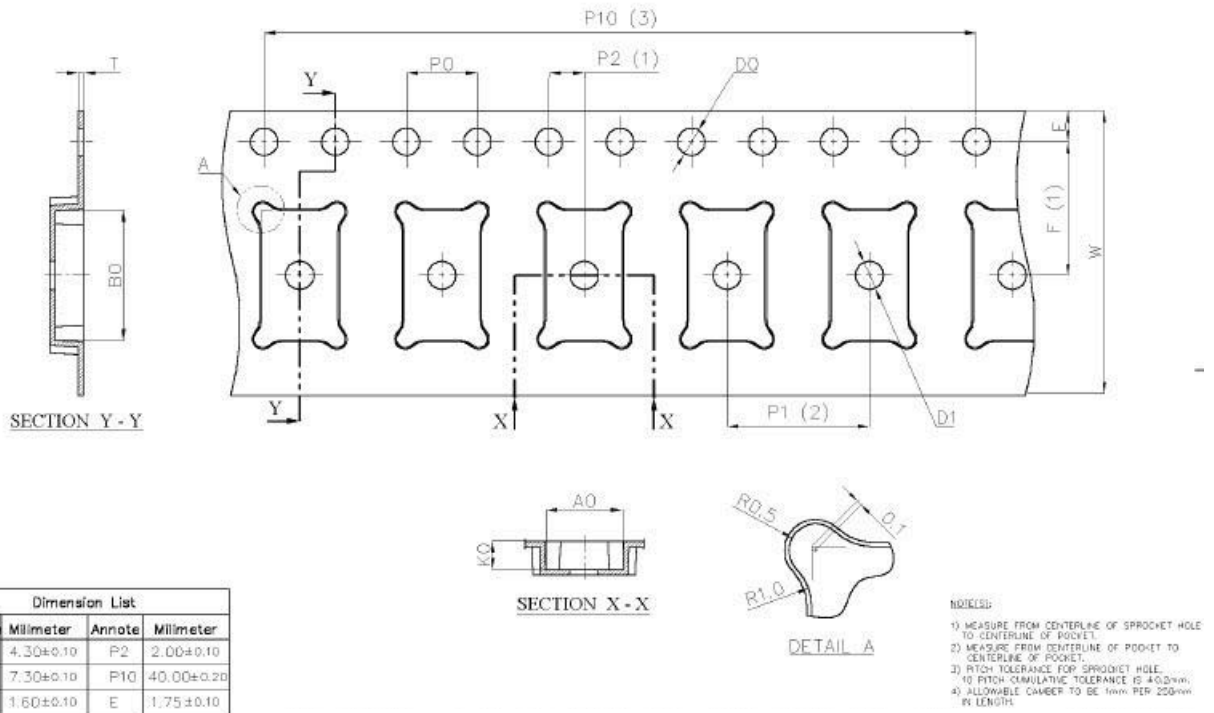

Figure 60. SMT Tape Packing

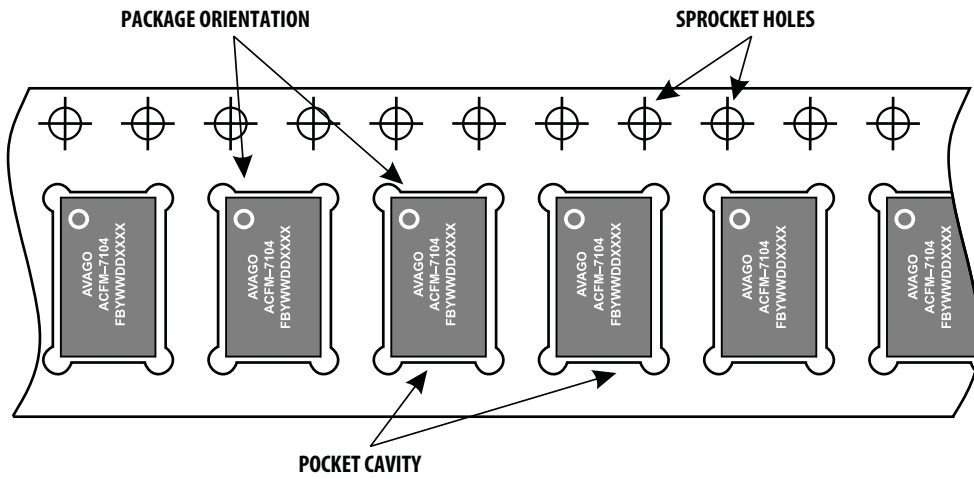
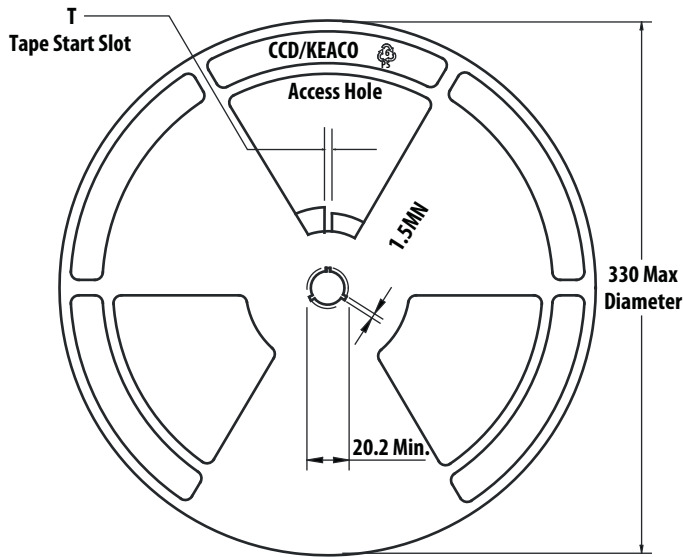
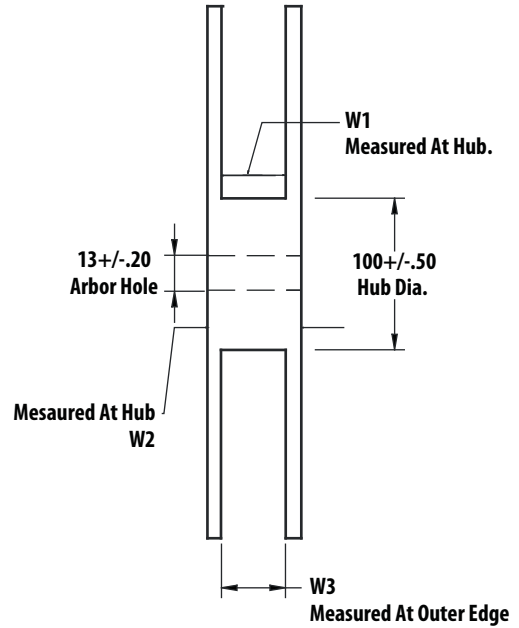

Figure 61. Orientation in Tape



**NOTE:**  
**44MM HUB DIE**  
**152+/- .50**



Tape Width	T	W1	W2	W3
16mm	7+/-0.50	16.4+2.0 -0.0	22.4 Max	15.9 min 19.4 max
24mm	7+/-0.50	24.4+2.0 -0.0	30.4 Max	23.9 min 27.4 max
32mm	10+/-0.50	32.4+2.0 -0.0	38.4 Max	31.9 min 35.4 max
44mm	10+/-0.50	44.4+2.0 -0.0	51.0 Max	44.0 min 48.0 max
56mm	10.7+/-0.50	56.9+2.0 -0.0	63.0 Max	55.9 min 59.9 max

**Figure 62. Reel Drawing**

### Ordering Information

Part Number	No. of Devices	Container
ACFM-7104-BLK	100	Anti-static Bag
ACFM-7104-TR1	3000	13-inch Reel

For product information and a complete list of distributors, please go to our web site: [www.avagotech.com](http://www.avagotech.com)

Avago, Avago Technologies, and the A logo are trademarks of Avago Technologies in the United States and other countries. Data subject to change. Copyright © 2005-2010 Avago Technologies. All rights reserved. AV02-2301EN - January 29, 2010

