

ACFM-7110

PCS/Cellular Band Quadplexer

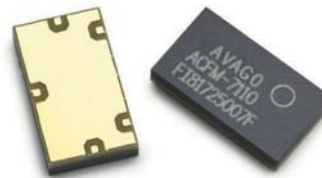

Data Sheet



Description

The Avago Technologies' ACFM-7110 is a quadplexer that combines PCS and Cellular duplexers into a single, miniature package.

The ACFM-7110 features a single antenna connection, eliminating the need for antenna switching. All ports are matched to 50 ohms.

The ACFM-7110 is designed with Avago Technologies' Film Bulk Acoustic Resonator (FBAR) technology. The ACFM-7110 also utilizes Avago Technologies' innovative Microcap bonded-wafer, chip scale packaging technology. This process allows the filters to be assembled in a module with a footprint of only 3 x 5 mm and maximum height of 1.05 mm.

Low Tx Insertion Loss of the ACFM-7110 reduces power amplifier current, extending battery life and talk time. The ACFM-7110 enhances receiver sensitivity and dynamic range with low Rx Insertion Loss and high rejection of Tx signals at the Rx ports.

The excellent power handling capability of Avago Technologies' FBAR bulk-mode resonators supports the high Tx output power levels needed in handsets while adding virtually no distortion.

Functional Block Diagram

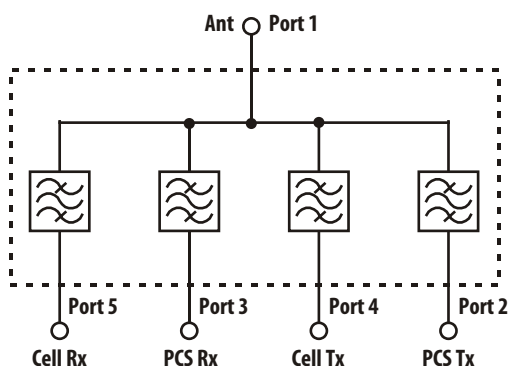

Features

- Single Antenna
- All ports matched to 50 ohms
- Miniature size
 - 3 x 5 mm footprint
 - 1.05 mm max height
- High Power Rating
 - +33 dBm Max Tx Power
- Environmental
 - RoHS Compliant
 - Halogen Free
 - TBBPA Free

Specifications

- Performance guaranteed -20° to +85° C
- Cellular Duplexer Rx (869 – 894 MHz)
 - Insertion Loss: 3.5 dB Max (25° C)
 - Noise Blocking: 45 dB Min
- Cellular Duplexer Tx (824 – 849 MHz)
 - Insertion Loss: 2.8 dB Max (25° C)
 - Interferer Blocking: 55 dB Min
- PCS Duplexer Rx (1930.5 – 1989.5 MHz)
 - Insertion Loss: 3.4 dB Max (25° C)
 - Noise Blocking: 45 dB Min (25° C)
- PCS Duplexer Tx (1850.5 – 1909.5 MHz)
 - Insertion Loss: 2.9 dB Max (25° C)
 - Interferer Blocking: 54 dB Min

Applications

- Handsets or data terminals operating in the PCS and Cellular frequency bands

ACFM-7110 Electrical Specifications, $Z_0 = 50 \Omega$, T_C [1,2] as indicated

Symbol	Parameter	Units	-20° C		+25° C			+85° C	
			Min	Max	Min	Typ ^[3]	Max	Min	Max
Cellular Duplexer Performance									
Antenna Port to Cellular Receive Port									
S41	Insertion Loss in Rx Band (869–894 MHz)	dB		3.6		1.9	3.5		3.6
S41	Insertion Loss Ripple (p-p) in Rx Band (869 – 894 MHz)	dB				1.0	1.5		
S41	Attenuation in Tx Band (824 – 849 MHz)	dB	50		50	66		50	
S41	Attenuation, 0 – 804 MHz	dB	25		25			25	
S41	Attenuation in Tx 2 nd harmonic Band (1648 – 1698 MHz)	dB	30		30			30	
S41	Attenuation in Tx 3 rd harmonic Band (2472 – 2547 MHz)	dB	19		19			19	
S44	Return Loss (SWR) of Rx Port in Rx Band (869 – 894 MHz)	dB	8	(2.3)	8	15 (1.4)	(2.3)	8	(2.3)
S11	Return Loss (SWR) of Ant Port in Rx Band (869 – 894 MHz)	dB	8	(2.3)	8	18 (1.3)	(2.3)	8	(2.3)
Cellular Transmit Port to Antenna Port									
S15	Insertion Loss in Tx Band (824 – 849 MHz)	dB		2.9		1.6	2.8		2.9
S15	Insertion Loss Ripple (p-p) in Tx Band (824 – 849 MHz)	dB				0.8	1.5		
S15	Attenuation in Rx Band (869 – 894 MHz)	dB	40		40	56		40	
S15	Attenuation, 0 – 804 MHz	dB	20		20			20	
S15	Attenuation in GPS Band (1574.4 – 1576.4 MHz)	dB	30		30			30	
S15	Attenuation in Tx 2 nd harmonic Band (1648 – 1698 MHz)	dB	20		20			20	
S15	Attenuation in Tx 3 rd harmonic Band (2472 – 2547 MHz)	dB	8		8			8	
S55	Return Loss (SWR) of Tx Port in Tx Band (824 – 849 MHz)	dB	9	(2.1)	9	16 (1.4)	(2.1)	9	(2.1)
S11	Return Loss (SWR) of Ant port in Tx Band (824 – 849 MHz)	dB	9	(2.1)	9	22 (1.2)	(2.1)	9	(2.1)
Isolation, Cellular Transmit Port to Cellular Receive Port									
S45	Isolation, Tx to Rx port in Rx Band (869 – 894 MHz)	dB	45		45	59		45	
S45	Isolation, Tx to Rx port in Tx Band (824 – 849 MHz)	dB	55		55	64		55	

ACFM-7110 Electrical Specifications, $Z_0 = 50 \Omega$, T_C [1,2] as indicated

Symbol	Parameter	Units	-20°C		+25°C			+85°C	
			Min	Max	Min	Typ ^[3]	Max	Min	Max
PCS Duplexer Performance									
Antenna Port to PCS Receive Port									
S31	Insertion Loss in Rx Band (1930.5 – 1989.5 MHz)	dB		3.6		1.7	3.4		3.6
S31	Insertion Loss Ripple (p-p) in Rx Band	dB				1.1	2		
S31	Attenuation in Tx Band (1850.5 – 1909.5 MHz)	dB	50		50	61		50	
S31	Attenuation, 0.03 – 1770 MHz	dB	20		20			20	
S31	Attenuation, 2025 – 3500 MHz	dB	30		30			30	
S31	Attenuation, 3500 – 3700 MHz	dB	27		27			27	
S31	Attenuation, 3820 – 4000 MHz	dB	23		23			23	
S33	Return Loss (SWR) of Rx Port in Rx Band (1930.5 – 1989.5 MHz)	dB	9	(2.1)	9	18 (1.3)	(2.1)	9	(2.1)
S11	Return Loss (SWR) of Ant Port in Rx Band (1930.5 – 1989.5 MHz)	dB	9	(2.1)	9	20 (1.2)	(2.1)	9	(2.1)
PCS Transmit Port to Antenna Port									
S12	Insertion Loss in Tx Band (1850.5 – 1909.5 MHz)	dB		3.1		1.3	2.9		3.1
S12	Insertion Loss Ripple (p-p) in Tx Band	dB				0.8	2		
S12	Attenuation in Rx Band (1930.5 – 1989.5 MHz)	dB	40		40	54		40	
S12	Attenuation, 0.03 – 1570 MHz	dB	15		15			15	
S12	Attenuation in GPS Band (1574.4 – 1576.4 MHz)	dB	30		30			30	
S12	Attenuation, 1580 – 1700 MHz	dB	25		25			25	
S12	Attenuation in Tx 2 nd harmonic Band (3701 – 3819 MHz)	dB	10		10			10	
S12	Attenuation in Tx 3 rd harmonic Band (5551.5 – 5728.5 MHz)	dB	3		3			3	
S22	Return Loss (SWR) of Tx Port in Tx Band (1850.5 – 1909.5 MHz)	dB	9.5	(2.0)	9.5	18 (1.3)	(2.0)	9.5	(2.0)
S11	Return Loss (SWR) of Ant port in Tx Band (1850.5 – 1909.5 MHz)	dB	9	(2.1)	9	20 (1.2)	(2.1)	9	(2.1)
Isolation, PCS Transmit Port to PCS Receive Port									
S32	Isolation, Tx to Rx port in Rx Band (1930.5 – 1989.5 MHz)	dB	40		45	60		45	
S32	Isolation, Tx to Rx port in Tx Band (1850.5 – 1909.5 MHz)	dB	54		54	65		54	

Notes:

1. T_C is defined as Case Temperature, the temperature of the bottom mounting surface of the quadplexer where it makes contact with the circuit board.
2. Min/Max specifications are guaranteed at the indicated temperature with the input power to the Tx ports equal to or less than +27 dBm over all Tx frequencies unless otherwise noted.
3. Typical data is the arithmetic mean value of the parameter over its indicated frequency range at the specified temperature. Typical values may vary over time.

Absolute Maximum Ratings^[1]

Parameter	Unit	Value
Storage temperature	°C	-65 to +125
Maximum RF Input Power to Tx Ports	dBm	+33

Maximum Recommended Operating Conditions^[2]

Parameter	Unit	Value
Operating temperature, T _c ^[3] , Tx Power ≤ 29 dBm	°C	-40 to +100
Operating temperature, T _c ^[3] , Tx Power ≤ 30 dBm	°C	-40 to +85

Notes:

1. Operation in excess of any one of these conditions may result in permanent damage to the device.
2. The device will function over the recommended range without degradation in reliability or permanent change in performance, but is not guaranteed to meet electrical specifications.
3. T_c is defined as Case Temperature, the temperature of the bottom mounting surface of the quadplexer where it makes contact with the circuit board.

ACFM-7110 Typical Performance at $T_c = 25^\circ C$

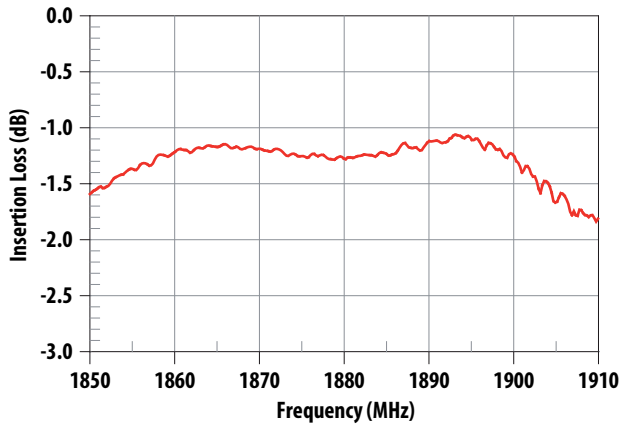

Figure 1. PCS Tx Band Insertion Loss.

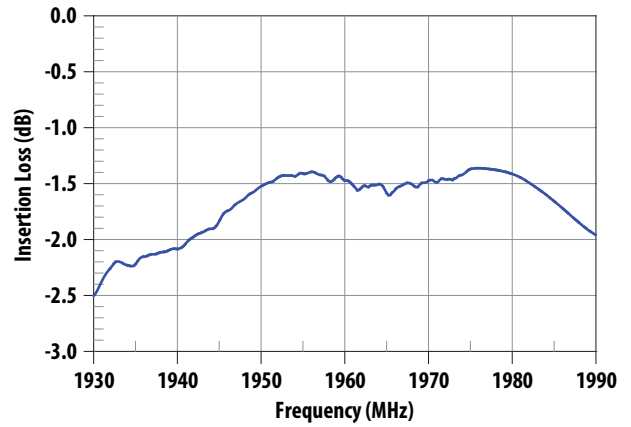

Figure 2. PCS Rx Band Insertion Loss.

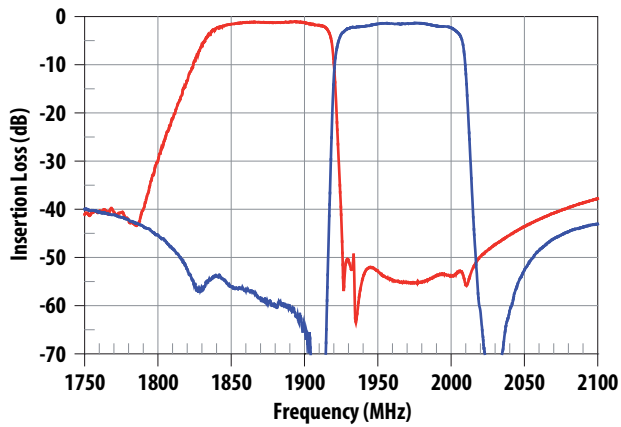

Figure 3. PCS Tx Rejection in Rx Band and Rx Rejection in Tx Band.

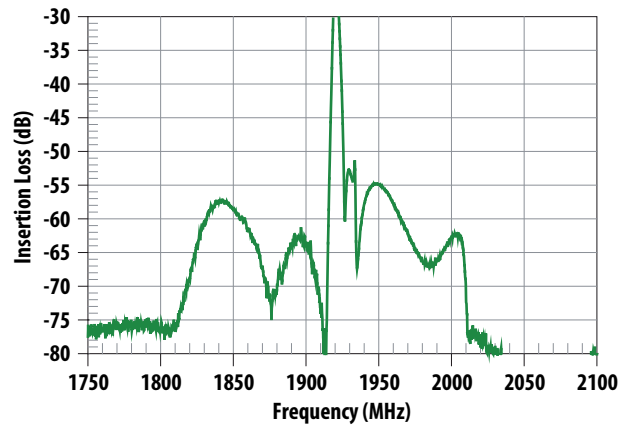

Figure 4. PCS Tx-Rx Isolation.

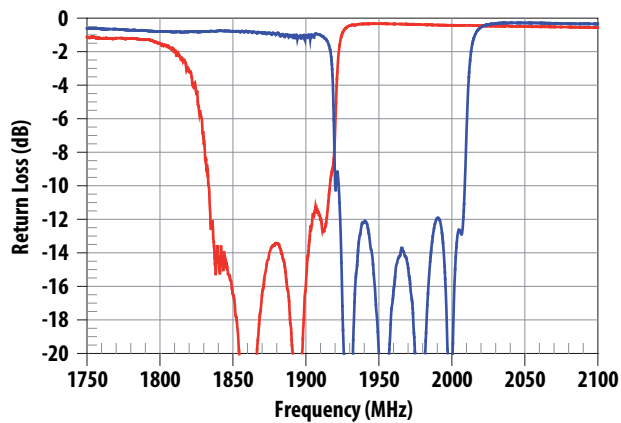

Figure 5. PCS Tx and Rx Port Return Loss.

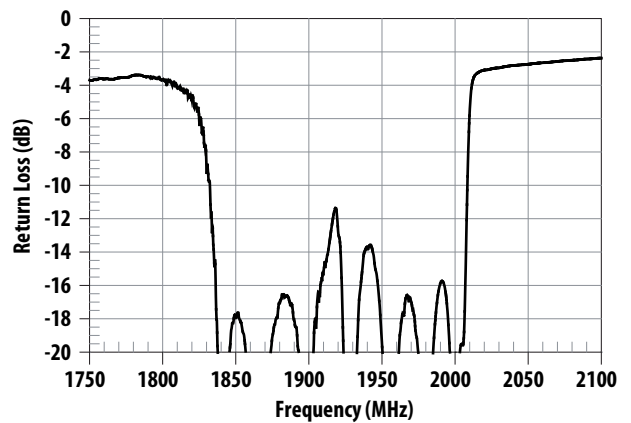

Figure 6. PCS Antenna Port Return Loss.

ACFM-7110 Typical Performance at $T_c = 25^\circ C$

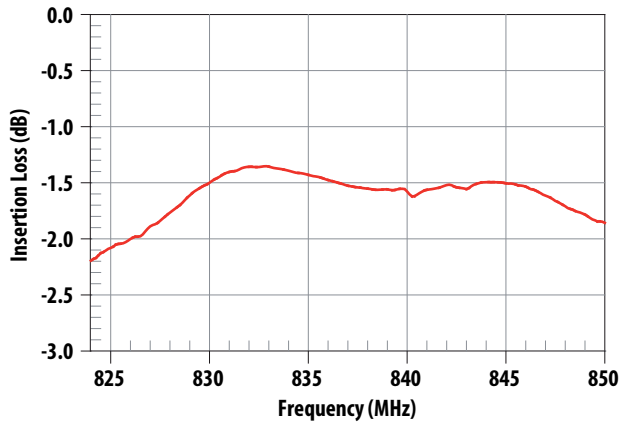

Figure 7. Cellular Tx Insertion Loss.

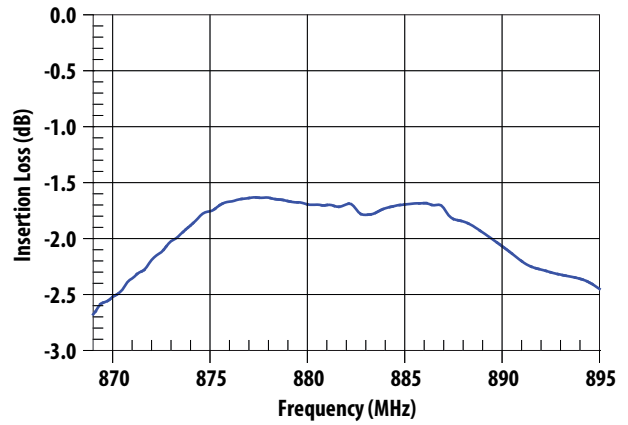

Figure 8. Cellular Rx Insertion Loss.

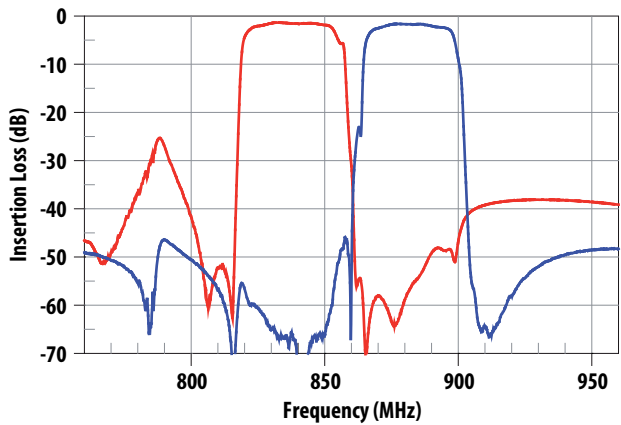

Figure 9. Cellular Tx Rejection in Rx Band and Rx Rejection in Tx Band.

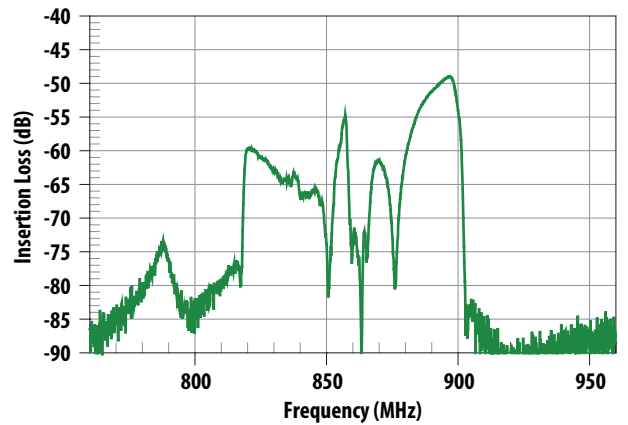

Figure 10. Cellular Tx-Rx Isolation.

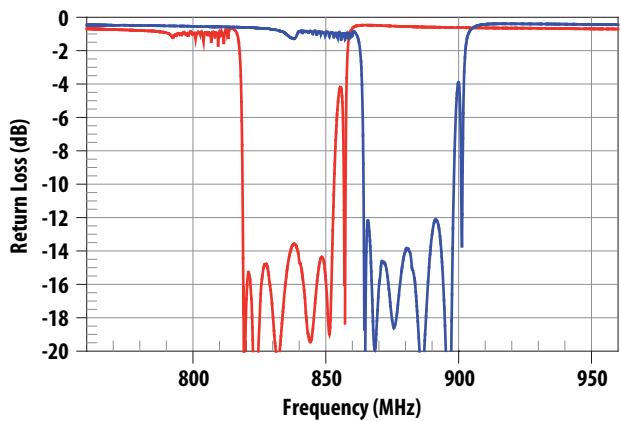

Figure 11. Cellular Tx and Rx Return Loss.

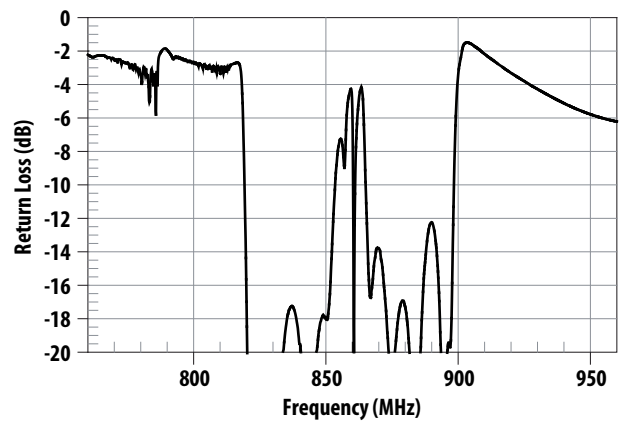

Figure 12. Cellular Band Antenna Return Loss.

ACFM-7110 Typical Performance at $T_c = 25^\circ\text{C}$

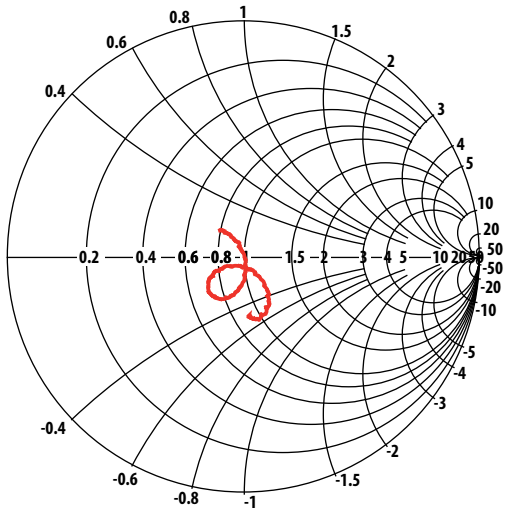

Figure 13. PCS Tx Port Impedance in Tx Band (1850–1910 MHz).

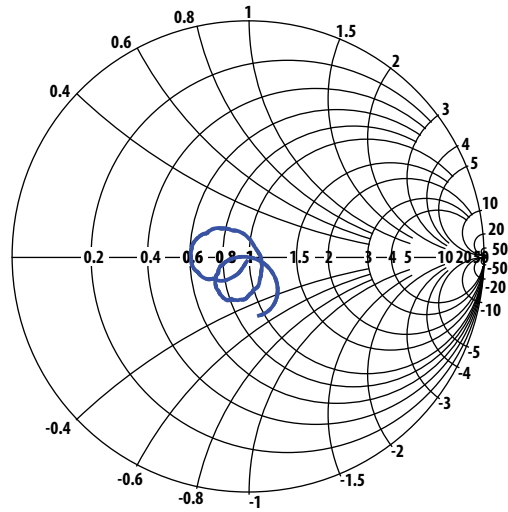

Figure 14. PCS Rx Port Impedance in Rx Band (1930–1990 MHz).

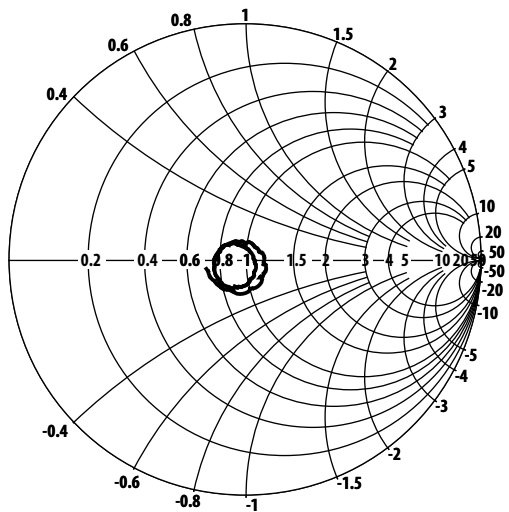

Figure 15. Ant Port Impedance in PCS Tx Band (1850–1910 MHz).

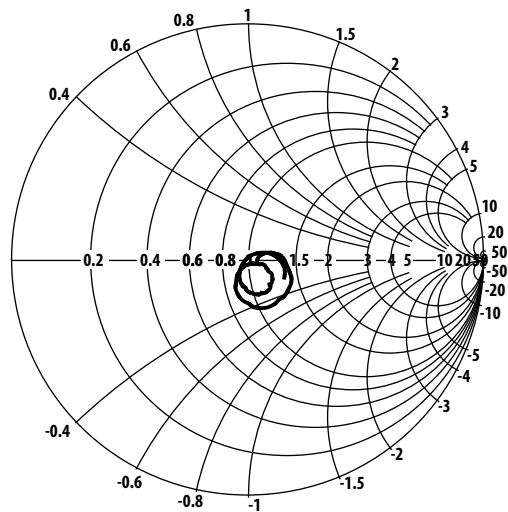

Figure 16. Ant Port Impedance in PCS Rx Band (1930–1990 MHz).

ACFM-7110 Typical Performance at $T_c = 25^\circ\text{C}$

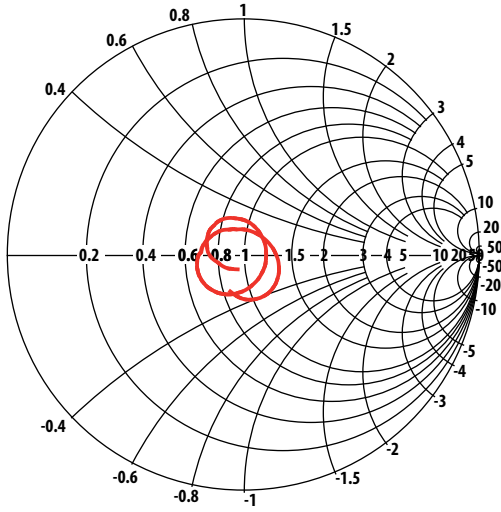

Figure 17. Cell Tx Port Impedance in Tx Band (824–849 MHz).

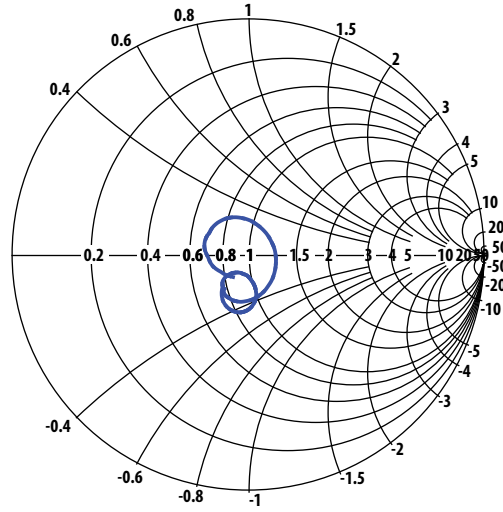

Figure 18. Cell Rx Port Impedance in Rx Band (869–894 MHz).

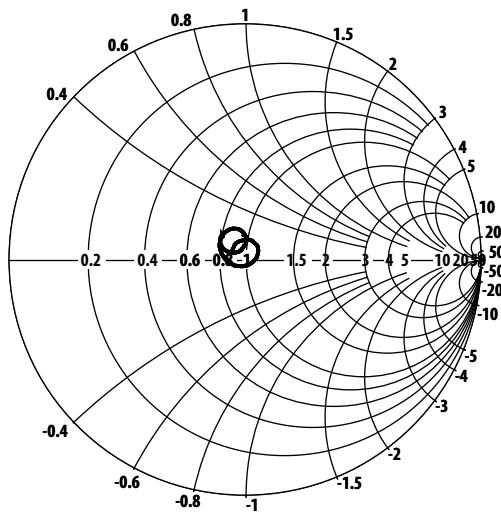

Figure 19. Ant Port Impedance in Cell Tx Band (824–849 MHz).

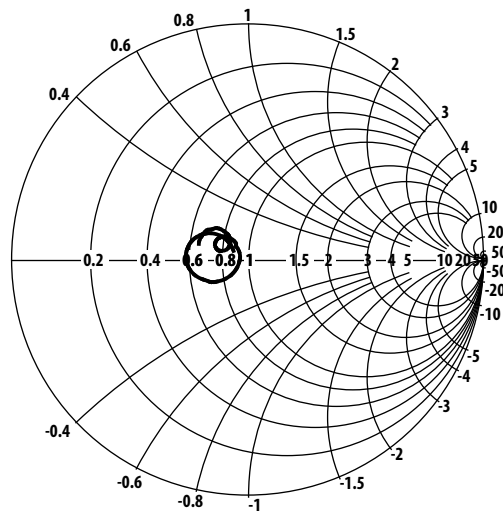

Figure 20. Ant Port Impedance in Cell Rx Band (869–894 MHz).

ACFM-7110

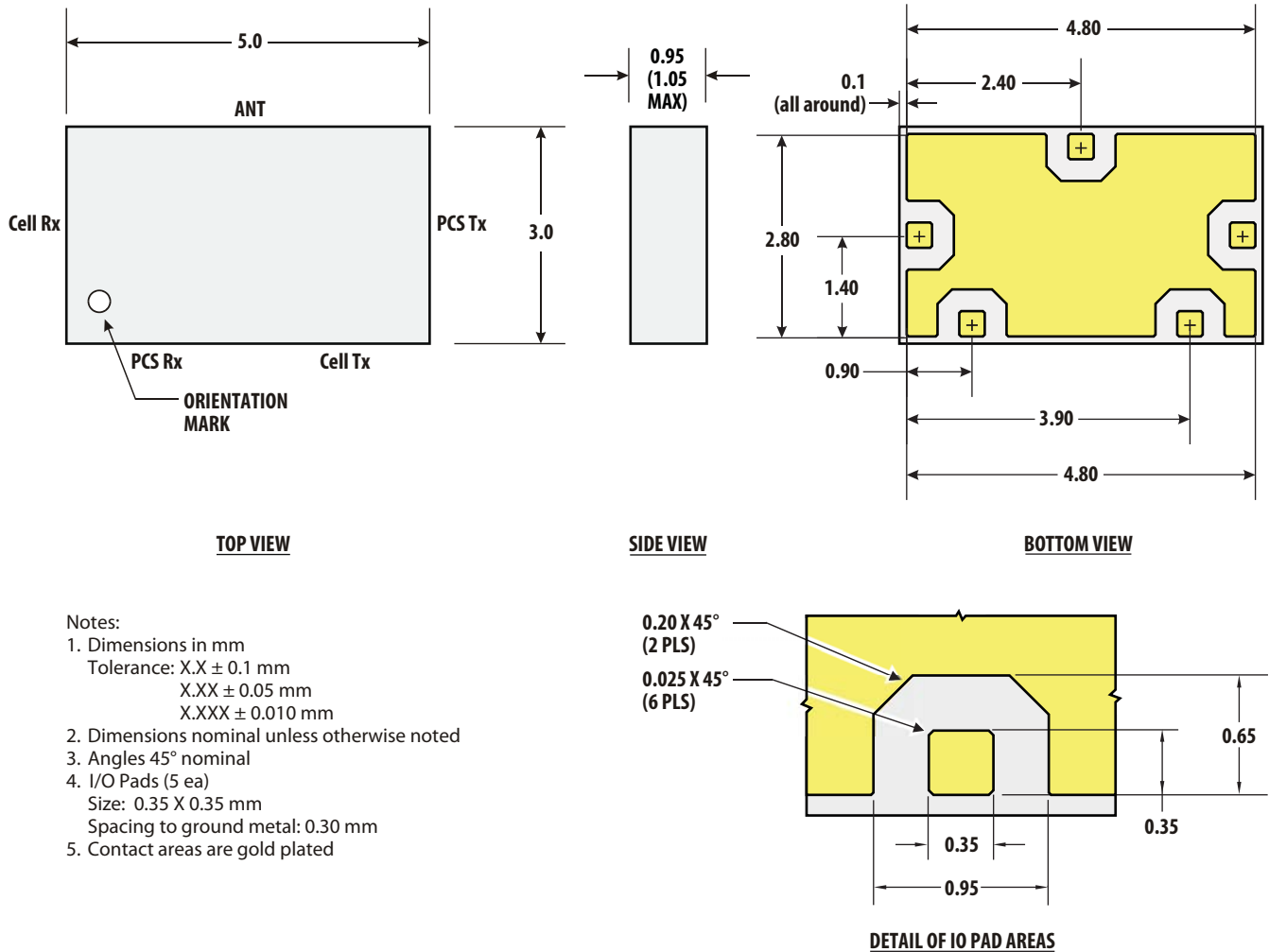

Figure 21. Package Outline Drawing.

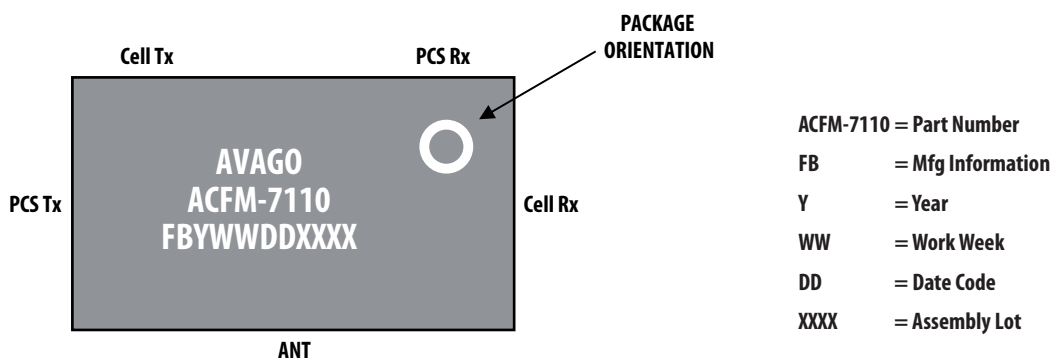

Figure 22. Package Marking

ACFM-7110

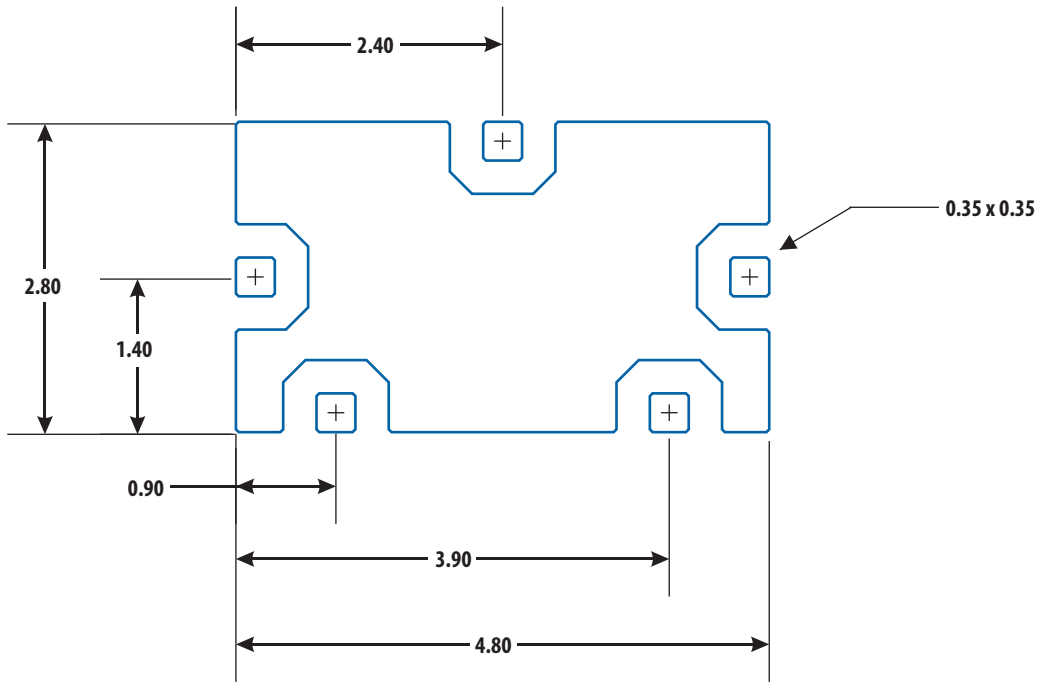

Figure 23. ACFM-7110 Footprint, Dimensions in mm (top view).

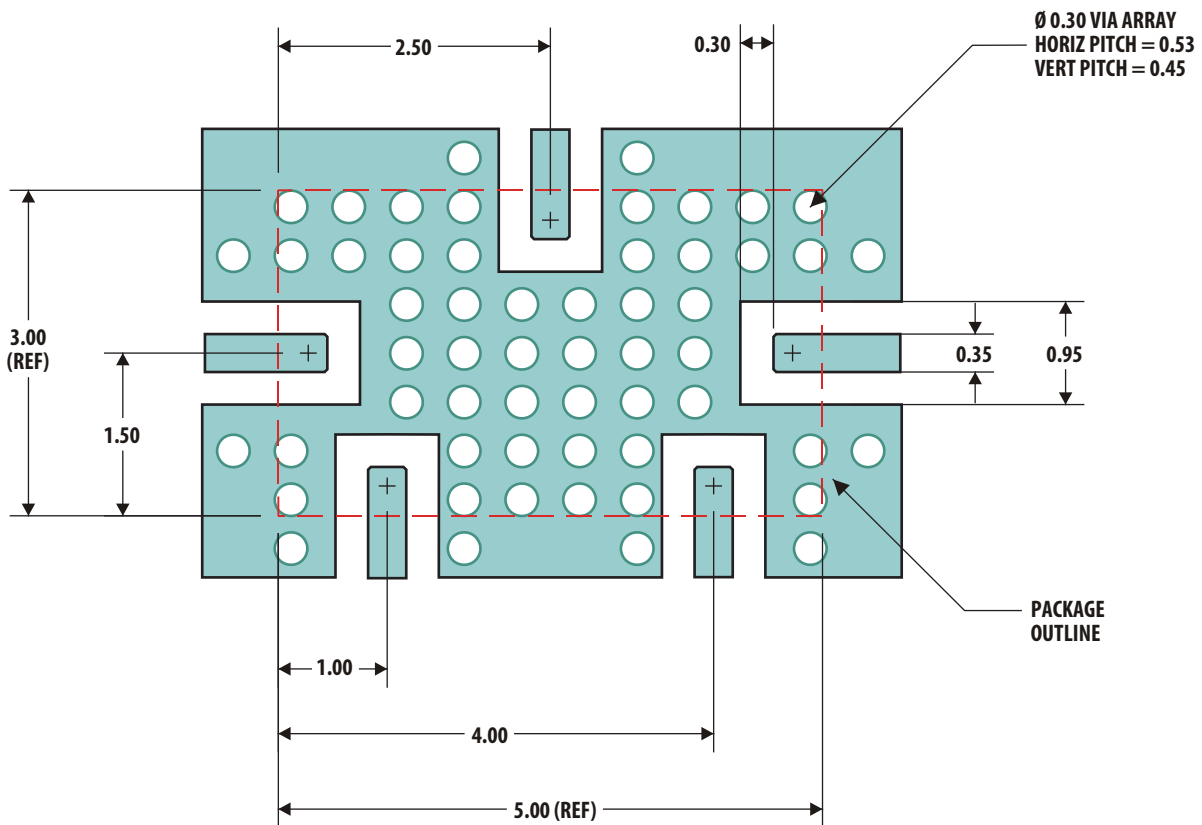

Figure 24. Suggested PCB Layout, Dimensions in mm (top view).

ACFM-7110

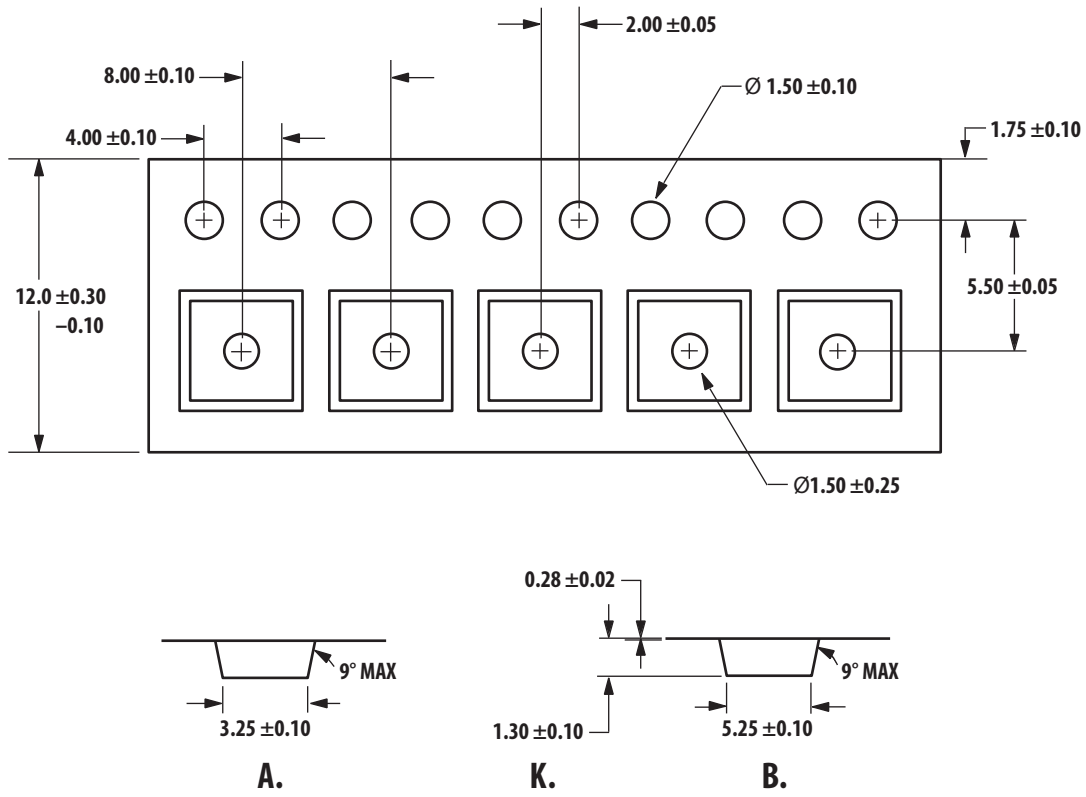

Figure 25. SMT Tape Packing (12 mm tape).

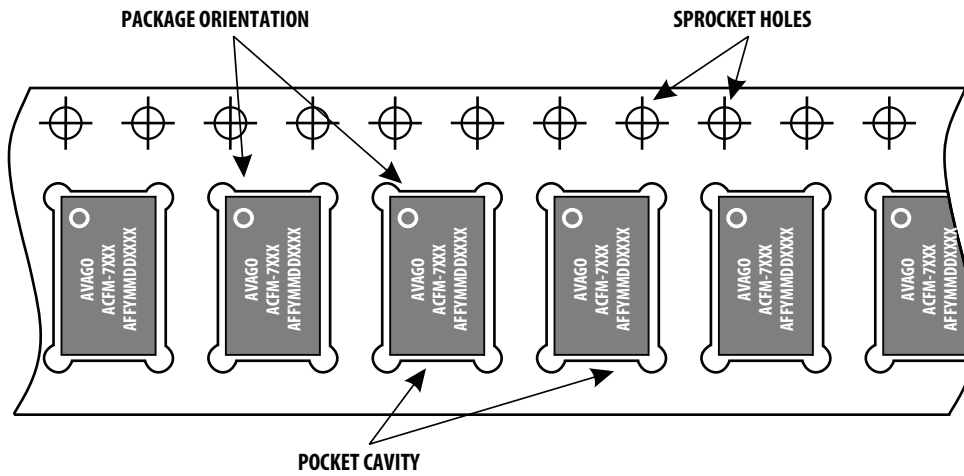
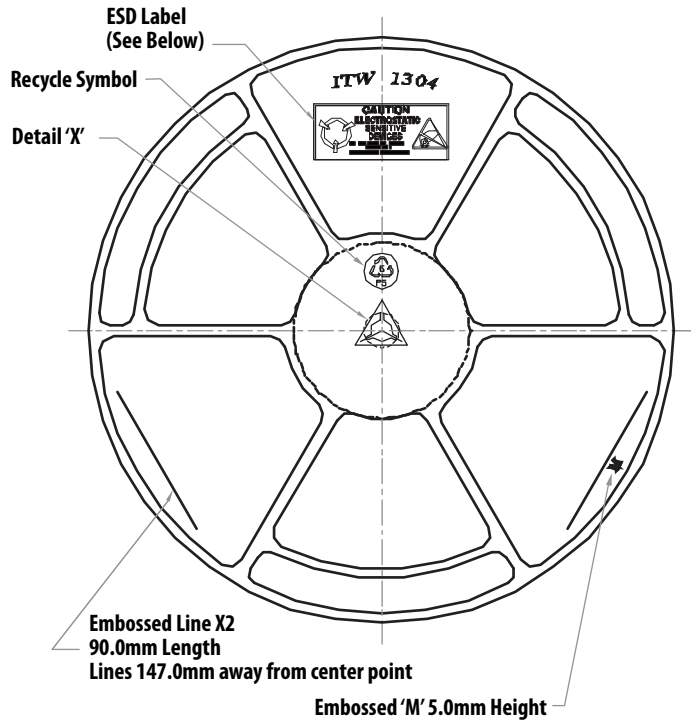

Figure 26. Orientation in Tape.

ACFM-7110



NO.	COLOR	SURFACE RESISTIVITY
1.	Pantone 285U Dark Blue	Antistatic Coated 10 ⁶ -10 ¹⁰ Per Ohms Square
2.	Black	Conductive <10 ⁶ Per Ohms Square
3.	White	Antistatic Impregnated 10 ⁶ -10 ¹⁰ Per Ohms Square
4.	Pantone 3295C Dark Green	Antistatic Coated 10 ⁶ -10 ¹⁰ Per Ohms Square
5.	Black	Antistatic Coated 10 ⁶ -10 ¹⁰ Per Ohms Square
6.	Pantone 278C Light Blue	Antistatic Coated 10 ⁶ -10 ¹⁰ Per Ohms Square
7.	White	Antistatic Coated 10 ⁶ -10 ¹⁰ Per Ohms Square
8.	Natural	Antistatic Coated 10 ⁶ -10 ¹⁰ Per Ohms Square
9.	Pantone 298C-299C Dull Light Blue	Antistatic Coated 10 ⁶ -10 ¹⁰ Per Ohms Square

Note: X in Part Numbering denotes colour code.

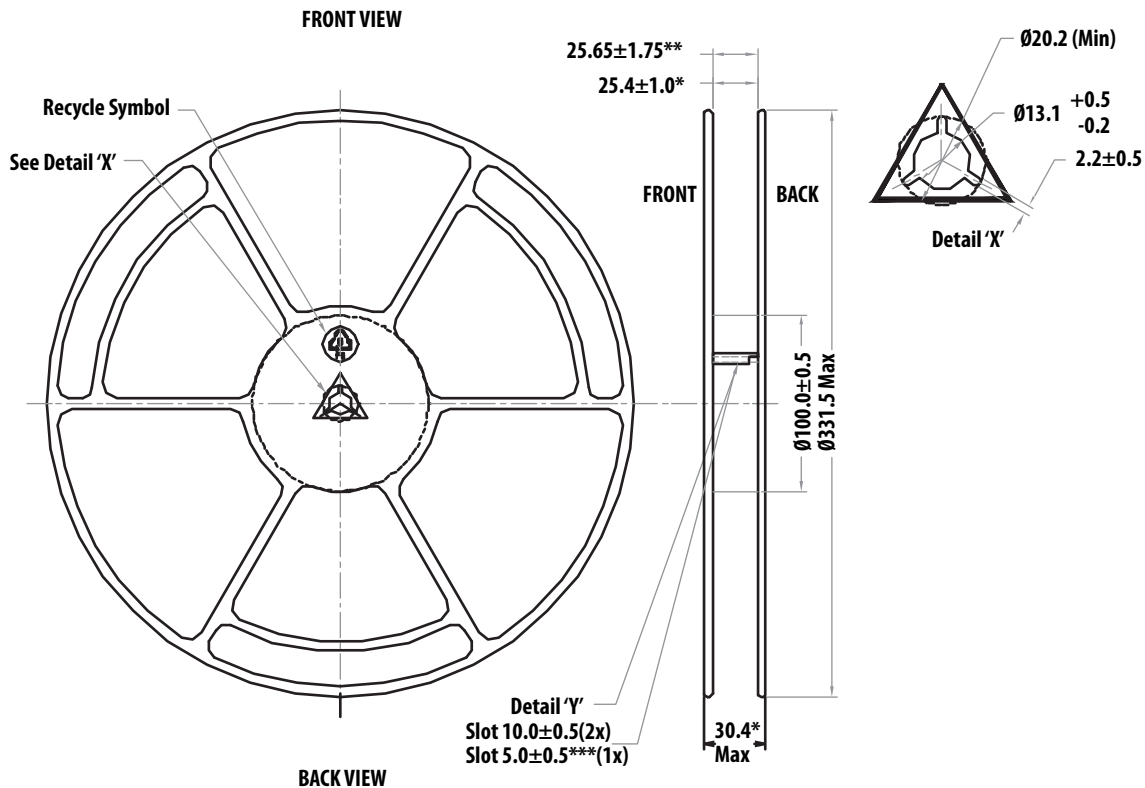

Notes:

1. Reel (coated with proprietary antistatic agent), 10⁹ to 10¹¹ Ohm / Sq
2. Carrier Tape (Carbon Polystyrene), 10⁹ Ohm / Sq
3. Cover Tape, 10¹⁰ to 10¹¹ Ohm / Sq
 - Top layer – Transparent PET film
 - Bonding Layer – Adhesive Polyolefin
 - Sealing Layer – Peelable special film

Figure 27. Reel Drawing.

ACFM-7110

Package Moisture Sensitivity

Feature	Test Method	Performance
Moisture Sensitivity Level (MSL) at 260° C	J-STD-20C	Level 3

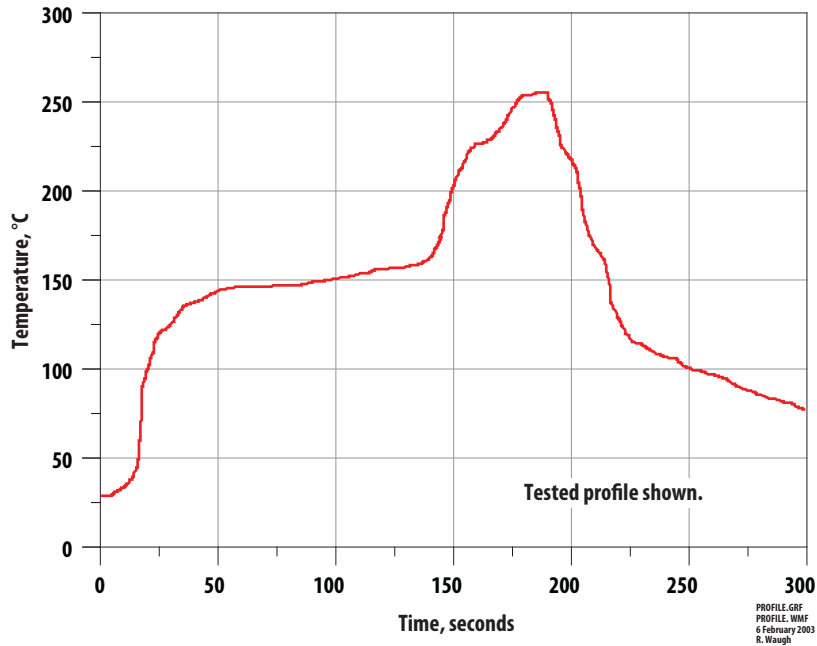

Figure 28. Verified SMT Solder Profile.

Part Number	No. of Devices	Container
ACFM-7110-BLK	100	Tape Strip or Anti-static Bag
ACFM-7110-TR1	3000	330 mm (13-inch) Reel

For product information and a complete list of distributors, please go to our web site: www.avagotech.com

Avago, Avago Technologies, and the A logo are trademarks of Avago Technologies in the United States and other countries. Data subject to change. Copyright © 2005-2011 Avago Technologies. All rights reserved. AV02-2891EN - March 28, 2011

AVAGO
TECHNOLOGIES