



# ACL406AS - Direct AC Line LED Driver

UP TO 6W OUTPUT

ACL406AS-DS-V1.1 – February 2022



## Datasheet



MATURITY  
In Production

### 1. FEATURES

#### ACL406AS up to 6W output,

- Direct AC Line LED Driver requiring few external components,
- Wide AC Input Range: 50 to 280V AC,
- High Power Factor: > 0.98 with optimized LED configuration,
- Low harmonic content: THD < 15% (typ.),
- Low quiescent current: 120µA,
- High Efficiency: 85% typical,
- Ultra-Flexible LED Forward Voltage Configuration,
- Up to 4 LED stages capability,
- flicker index: 10%,
- Over Temperature Power derating.

### 2. APPLICATIONS

- General Solid State Lighting,
- Medium Power LED Lamp,
- Connected Medium Power Led Lamp,
- Industrial high power LED Lamp.

### 3. DESCRIPTION

The ACL406AS is an AC direct LED driver requiring few external components: a diode bridge to rectify the AC voltage and a resistor to tune the LED current.

Multiple ACL406AS AC line drivers may be used in parallel to drive high power LED systems for industrial applications.

### 4. PIN CONNECTIONS

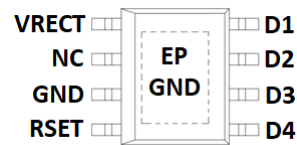

Figure 1: SO8 with Exposed Pad (TOP VIEW)

### 5. TYPICAL APPLICATIONS

Recommended design for 230V<sub>AC</sub> Low-Cost Bulbs with protections

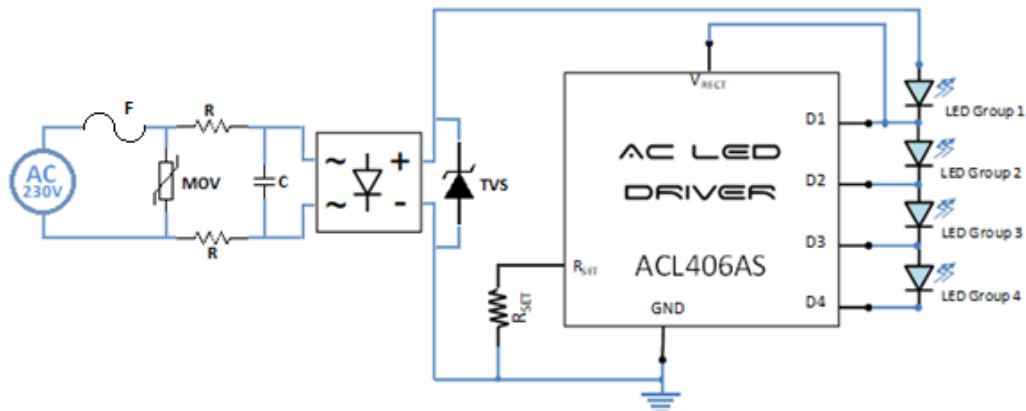

Figure 2: Recommended application with protection

## TABLE OF CONTENTS

1. Features.....	1
2. Applications.....	1
3. Description.....	1
4. Pin Connections.....	1
5. Typical Applications.....	1
Recommended design for 230V <sub>AC</sub> Low-Cost Bulbs with protections.....	1
6. Revision History.....	2
7. Pin configuration.....	3
Pin descriptions and Functions.....	3
ACL406AS Pin Mapping (with exposed pad).....	3
8. Absolute Maximum Ratings.....	3
9. Electrical Characteristics.....	4
Operating Conditions.....	4
Electrical Parameters.....	4
10. Functional Description.....	5
LED Current Setting.....	5
Over temperature and LED failure Protection.....	5
R <sub>SET</sub> open/short Protection.....	5
11. Package Description.....	6
ACL406AS: SO8 with exposed pad.....	6
PCB Footprint ACL406AS:.....	6
12. ORDERING INFORMATION.....	6

## 6. REVISION HISTORY

Version	Date	Changes
1.0	22/06/2021	1 <sup>st</sup> public release

NOTE: Page numbers for previous revisions may differ from page numbers in the current version.

## 7. PIN CONFIGURATION

### Pin descriptions and Functions

Symbol	Pin #	Type	Function
V <sub>RECT</sub>	1	PWR	Power supply
NC	2	-	Not Connected
GND	3	GND	Ground
R <sub>SET</sub>	4	IO	Resistor to set the LED current
D4	5	IO	Cathode LED group 4
D3	6	IO	Cathode LED group 3
D2	7	IO	Cathode LED group 2
D1	8	IO	Cathode LED group 1
EP	9	GND	Exposed Pad connected to the GND

Table 1: Pin description and functions

### ACL406AS Pin Mapping (with exposed pad)

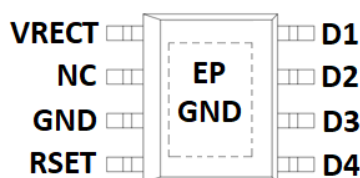

Figure 3: ACL406AS SO8 Pin-out with Exposed Pad (TOP VIEW)

## 8. ABSOLUTE MAXIMUM RATINGS

Parameter	Min	Typ	Max	Units
Input power supply V <sub>RECT</sub>	- 0.3		650	V
Output R <sub>SET</sub>	- 0.3		5	V
Output LED Voltage D1	- 0.3		650	V
Output LED Voltage D2	- 0.3		650	V
Output LED Voltage D3	- 0.3		650	V
Output LED Voltage D4	- 0.3		650	V
T <sub>junction</sub>	-55°C		175°C	°C
T <sub>storage</sub>	-55°C		150°C	°C
ESD-HBM			TBD	kV
ESD-FCDM			TBD	V

Table 2: Absolute maximum ratings

#### Notes (TBC):

- The **ACL406AS** product type has been submitted to and conforms with HTOL, PCON/MSL1/TMCL, PCON/MSL1/UHAST and HTSL qualification tests. Stress tests have been completed without rejects and were performed according to the requirements of the test reference.
- HTOL test reference is **JESD22-A108**. PCON/MSL1/TMCL test reference is according to the **JESD22-A113**, **JESD22-A104** standard. PCON/MSL1/UHAST test reference is according to the **JESD22-A113**, **JESD22-A118** standard. HTSL test reference is according to the **JESD22-A103** standard.
- The ACL406AS product withstands class I with immunity level A of latch-up **JESD78E** standard.
- The ACL406AS product passes ESD-HBM according to ANSI/ESDA/JEDEC JS-001-2014.
- The ACL406AS product passes ESD-FCDM according to ANSI /ESDA /JEDEC JS-002-2014.

## 9. ELECTRICAL CHARACTERISTICS

### Operating Conditions

Parameter	Min	Typ	Max	Units
Input power supply $V_{RECT}$			400	V
dV/dt			10	V. $\mu$ s <sup>-1</sup>
$V_{D1}$	0		400	V
Voltage difference $D_{n-1}-D_n$ ( $2 \leq n \leq 4$ )	0	75	100	V
$V_{D4}$	0	75	100	V
$R_{SET}$	10		100	$\Omega$
$T_{junction}^{\circ}$	-40		125	$^{\circ}$ C

Table 3: Operating conditions

\* If external  $V_{DD}$  is used to supply another device

### Electrical Parameters

Parameter	Conditions	Min	Typ	Max	Units
I <sub>QUIESCENT</sub>	ACL406AS @ $V_{RECT} = 20V$	84	120	156	$\mu$ A
$P_{LED}^*$	@25 $^{\circ}$ C, $V_{RECT}=230Vac$ , $R_{SET} = 12 \Omega$	-10%	8.22	+10%	W
Output power derating** from -40 $^{\circ}$ C to 100 $^{\circ}$ C			0.1		%/ $^{\circ}$ C
Output power derating Curie point ( $P_T = P_{25^{\circ}C}/2$ )			175		$^{\circ}$ C
Package Thermal Resistance $\Theta_{JA}$ *** ACL406AS			TBD		$^{\circ}$ C/W
Package Thermal Resistance $\Theta_{JC}$ (JESD15-3 norm)	ACL406AS		TBD		$^{\circ}$ C/W

Table 4: Electrical parameters

$$* P_{LED} = \frac{15.7 \cdot ID1 \cdot 75 + 18.3 \cdot ID2 \cdot 150 + 27 \cdot ID3 \cdot 225 + 23 \cdot ID4 \cdot 300}{100}$$

\*\* Power derating acts as a soft over temperature protection. LED current decreases with excessive IC temperature.

\*\*\* Warning: Junction-to-air thermal resistance depends greatly on user application and PCB layout. Thermal management of the lighting system has to be carefully managed and taken into account.

## 10. FUNCTIONAL DESCRIPTION

### LED Current Setting

For the ACL406AS, the LED current is set by an external resistor  $R_{SET}$ . Each channel's current sink level is calculated as follows:

Parameter	Conditions	value	Units
ILED	ACL406AS @25°C	$I_{D1}=0.88/(10+R_{SET})$	A
		$I_{D2}=0.93/(10+R_{SET})$	
		$I_{D3}=1.02/(10+R_{SET})$	
		$I_{D4}=1.20/(10+R_{SET})$	

Table 5: LED current setting

### Over temperature and LED failure Protection.

- In case of excessive temperature in the IC, thermal regulation is managed by regulating the delivered power and the associated temperature. The implemented output power acts as soft temperature protection. The LED current is decreased to regulate the junction temperature until a safe state is found.
- In case of LED failure, the output power derating acts also as a protection. If the group of LED n is broken (open circuit), the LED current will flow in the previous pin  $D_{n-1}$  of the IC. This will increase dissipated power and temperature too. The output power derating will activate to decrease temperature until a safe state is reached again.

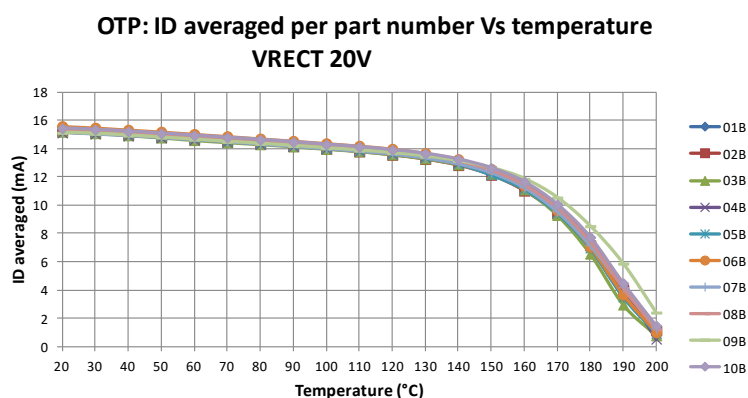

Figure 4: Output LED current derating vs temperature

### $R_{SET}$ open/short Protection.

When  $R_{SET}$  Pin is opened, the LED output current becomes zero.

When  $R_{SET}$  Pin is shorted to GND, a current limitation is enabled. It is set to a hundred of milliamperes and prevents damage to the IC.

## 11. PACKAGE DESCRIPTION

### ACL406AS: SO8 with exposed pad

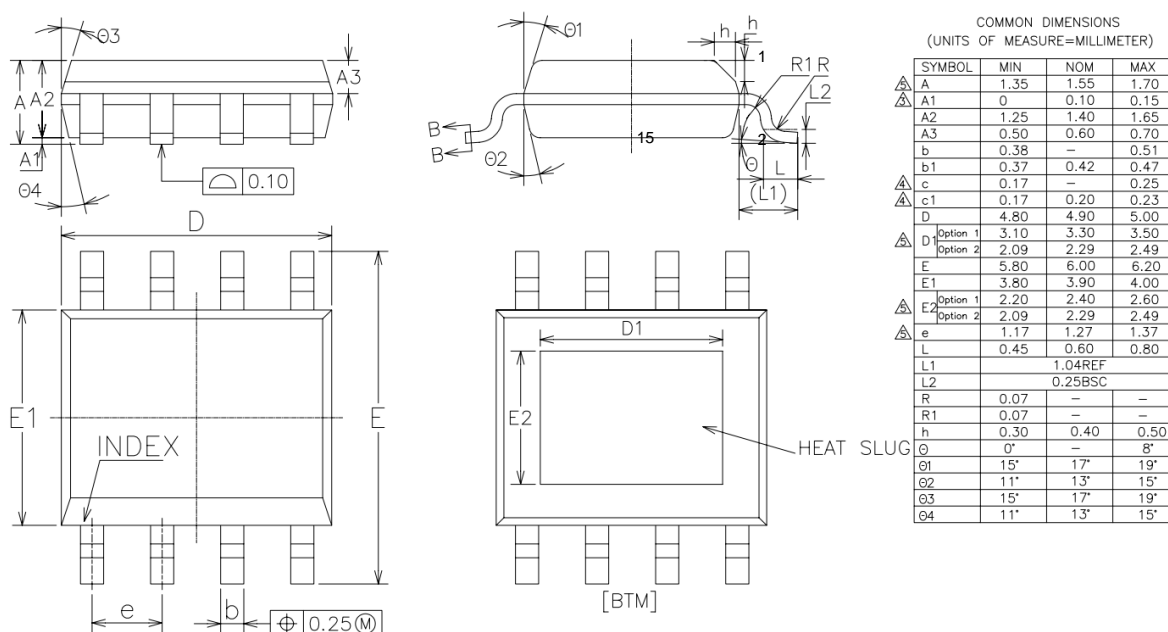

Figure 5: Package outline drawing

### PCB Footprint ACL406AS:

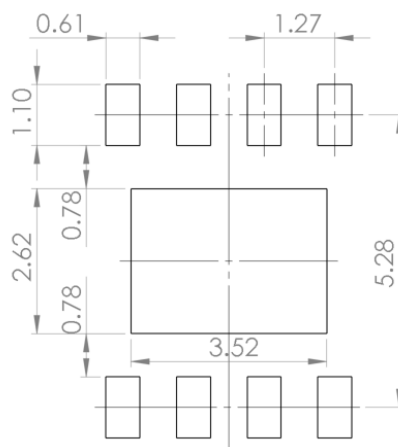

Figure 6: PCB footprint (TOP view). Size in mm.

Remark: the size 3.52 mm for the Exposed Pad is a minimum but could be increase to have a better thermal dissipation.

## 12. ORDERING INFORMATION

Device	Package	Shipping*
ACL406AS	SO8	Tape & Reel

Table 6: Ordering reference

\* Please, ask EASii IC for details of the quantity per reel with the part orientation.

### IMPORTANT NOTICE AND DISCLAIMER

EASii IC PROVIDES TECHNICAL AND RELIABILITY DATA (INCLUDING DATASHEETS), DESIGN RESOURCES (INCLUDING REFERENCE DESIGNS), APPLICATION OR OTHER DESIGN ADVICE, WEB TOOLS, SAFETY INFORMATION, AND OTHER RESOURCES “AS IS” AND WITH ALL FAULTS, AND DISCLAIMS ALL WARRANTIES, EXPRESS AND IMPLIED, INCLUDING WITHOUT LIMITATION ANY IMPLIED WARRANTIES OF MERCHANTABILITY, FITNESS FOR A PARTICULAR PURPOSE OR NON-INFRINGEMENT OF THIRD-PARTY INTELLECTUAL PROPERTY RIGHTS.

These resources are intended for skilled developers designing with EASii IC products. You are solely responsible for (1) selecting the appropriate EASii IC products for your application, (2) designing, validating and testing your application, and (3) ensuring your application meets applicable standards, and any other safety, security, or other requirements. These resources are subject to change without notice. EASii IC grants you permission to use these resources only for development of an application that uses the EASii IC products described in the resource. Other reproduction and display of these resources are prohibited. No license is granted to any other EASii IC intellectual property right or to any third-party intellectual property right. EASii IC disclaims responsibility for, and you will fully indemnify EASii IC and its representatives against, any claims, damages, costs, losses, and liabilities arising out of your use of these resources. EASii IC’s products are provided subject to EASii IC’s Terms of Sale ([www.easii-ic.com/en/legal/termsofsale.php](http://www.easii-ic.com/en/legal/termsofsale.php)) or other applicable terms available either on [www.easii-ic.com](http://www.easii-ic.com) or provided in conjunction with such EASii IC products. EASii IC’s provision of these resources does not expand or otherwise alter EASii IC’s applicable warranties or warranty disclaimers for EASii IC products.



EASii IC France: 90, Avenue Leon Blum 38100 Grenoble – France

Copyright © 2019 EASii IC

✉ : [sales-IC@easii-ic.com](mailto:sales-IC@easii-ic.com)

<http://www.easii-ic.com>