

AZ Displays, Inc.

1. MECHANICAL DATA

(1) Product No.	ACM4004C
(2) Module Size	190.0 (W)mm x 54.0 (H)mm x MAX9.5 (D)mm (W/O, EL B/L) 190.0 (W)mm x 54.0 (H)mm x MAX14.5 (D)mm (LED B/L)
(3) Dot Size	0.50 (W)mm x 0.55 (H)mm
(4) Dot Pitch	0.57 (W)mm x 0.62 (H)mm
(5) Number of Characters	40 (W) x 4 (H)Characters
(6) Character Format	5 (W) x 8 (H)Dots
(7) Duty	1/16
(8) LCD Display Mode	STN: <input type="checkbox"/> Gray Mode <input type="checkbox"/> Yellow Mode <input type="checkbox"/> Blue Mode FSTN: <input type="checkbox"/> Black and White(Normal White/Positive Image) <input type="checkbox"/> Black and White(Normal Black/Negative Image) Rear Polarizer: <input type="checkbox"/> Reflective <input type="checkbox"/> Transflective <input type="checkbox"/> Transmissive
(9) Viewing Direction	<input type="checkbox"/> 6 O'clock <input type="checkbox"/> 12 O'clock <input type="checkbox"/> ____O'clock
(10) Backlight	<input type="checkbox"/> W/O <input type="checkbox"/> EL B/L <input type="checkbox"/> LED B/L
(11) Weight	W/O B/L: 95.0 g(Approx.) EL B/L: 101.0 g(Approx.) LED B/L: 131.0 g(Approx.)

AZ Displays, Inc.

2. ABSOLUTE MAXIMUM RATINGS

(1) ELECTRICAL ABSOLUTE RATINGS

V_{SS}=0V

ITEM	SYMBOL	MIN	MAX	UNIT	COMMENT
Power Supply for Logic	VDD-VSS	-0.3	7.0	V	
Input Voltage	V _I	-0.3	VDD	V	
Static Electricity	-	-	-	-	Note 1

(2) ENVIRONMENTAL ABSOLUTE MAXIMUM RATINGS

ITEM	NORMAL TEMP.				WIDE TEMP.			
	OPERATING		STORAGE		OPERATING		STORAGE	
	MIN.	MAX.	MIN.	MAX.	MIN.	MAX.	MIN.	MAX.
Ambient Temperature	0	50	-20	70	-20	70	-30	80
Humidity (Without Condensation)	Note 2,4		Note 3,4		Note 4,5		Note 4,5	

Note 1 LCM should be grounded during handling.

Note 2 Ta ≤ 50°C : 85%RH max
 Ta > 50°C : Absolute humidity must be lower
 than the humidity of 85%RH at 50°C

Note 3 Ta at -20°C will be < 48hrs, at 70°C will be < 120hrs

Note 4 Background color changes slightly depending on ambient temperature.
 This phenomenon is reversible.

Note 5 Ta ≤ 70°C : 75%RH max
 Ta > 70°C : Absolute humidity must be lower
 than the humidity of 75%RH at 70°C

Note 6 Ta at -30°C will be < 48hrs, at 80°C will be < 120hrs

AZ Displays, Inc.

3. ELECTRICAL CHARACTERISTICS

(VDD= 5V ±10%)

ITEM	SYMBOL	CONDITION	MIN.	TYP.	MAX.	UNIT	
Input Voltage	V _{IH}	H level	0.7VDD	–	VDD	V	
	V _{IO}	L level	0	–	0.3VDD	V	
Recommended LC Driving Voltage (Normal Temp. LCM)	VDD–VO	0℃	–	4.8	5.4	V	
		25℃	4.2	4.7	5.2		
		50℃	3.8	4.3	–		
Recommended LC Driving Voltage (Wide Temp. LCM)	VDD–VO	–20℃	5.9	6.4	7.2	V	
		0℃	5.7	6.4	7.2		
		25℃	5.7	6.2	6.8		
		50℃	5.5	5.9	6.5		
		70℃	5.3	5.5	4.4		
Recommended LC Driving Voltage (Wide Temp. Low Voltage)	VDD–VO	–20℃	4.5	4.9	5.4	V	
		0℃	4.2	4.7	5.1		
		25℃	4.1	4.6	5.0		
		50℃	3.9	4.3	4.8		
		70℃	3.6	4.0	4.5		
Power Supply Current	I _{DD}	VDD = 5.0V	–	4.7	6.0	mA	
LED Power Supply Current	I _{LED}	V _{BL} = 5V _{DC} (R _{BL} = 5Ω)	–	200	–	mA	
EL Power Supply Current	I _{EL}	V _{BL} = 110V _{AC} 400Hz	–	–	10.0	mA	
Surface Luminance	L	VDD=5V VDD–VO =6.2V FLM= 70Hz	PATTERN: (Dots All On) ■ ■ ■ ■ ■ ■ ■ ■	–	22.8	–	cd/m ²
			PATTERN: (Dots All Off) □ □ □ □ □ □ □ □	–	6.6	–	

AZ Displays, Inc.

4-1. OPTICAL CHARACTERISTICS

(FOR NORMAL TEMPERATURE MODE LCM)

AT V_{op}

ITEM MODE		Cr(Contrast Ratio)		θ (Viewing Angle)		ϕ (Viewing Angle)	
		25℃		25℃		25℃	
		MIN.	TYP.	MIN.	TYP.	MIN.	TYP.
R	A/B	3.0	4.0	40	65	25	35
	C/D	5.0	8.0	50	70	28	38
	J/K	—	—	—	—	—	—
S	A/B	3.0	4.0	35	60	20	32
	C/D	4.0	7.0	45	65	25	35
	J/K	—	—	—	—	—	—
T	E/F	2.5	3.0	30	50	20	30
	C/D	2.5	5.0	30	50	20	30
NOTE		NOTE 6		NOTE 5			

NOTE :

R: REFLECTIVE
 S: TRANSFLECTIVE
 T: TRANSMISSIVE
 A/B: GRAY
 C/D: YELLOW
 E/F: BLUE
 J/K: NORMALLY WHITE

AT $\phi=0^\circ \theta=0^\circ$

ITEM	SYMBOL	CONDITION	MIN.	TYP.	MAX.	UNIT	NOTE
Response Time (rise)	Tr	0℃	—	460	900	ms	NOTE 2
		25℃	—	110	220		
		50℃	—	65	130		
Response Time (fall)	Tf	0℃	—	420	800	ms	NOTE 2
		25℃	—	140	250		
		50℃	—	90	155		

AZ Displays, Inc.

4-2.OPTICAL CHARACTERISTICS

(FOR WIDE TEMPERATURE MODE LCM)

AT Vop

ITEM MODE		Cr(Contrast Ratio)		θ (Viewing Angle)		ϕ (Viewing Angle)	
		25℃		25℃		25℃	
		MIN.	TYP.	MIN.	TYP.	MIN.	TYP.
R	A/B	3.5	4.3	40	65	25	35
	C/D	5.5	9.0	50	70	28	38
	J/K	—	—	—	—	—	—
S	A/B	3.2	4.1	35	60	20	32
	C/D	4.5	7.5	45	65	25	35
	J/K	—	—	—	—	—	—
T	E/F	2.7	3.3	30	50	20	30
	C/D	3.0	5.5	30	50	20	30
NOTE		NOTE 6		NOTE 5			

NOTE :

R: REFLECTIVE
S: TRANSFLECTIVE
T: TRANSMISSIVE
A/B: GRAY

C/D: YELLOW
E/F: BLUE
J/K: NORMALLY WHITE

AT $\phi=0^\circ$ $\theta=0^\circ$

ITEM	SYMBOL	CONDITION	MIN.	TYP.	MAX.	UNIT	NOTE
Response Time (rise)	Tr	-20℃	—	1500	3000	ms	NOTE 2
		0℃	—	270	540		
		25℃	—	120	240		
		50℃	—	70	140		
		70℃	—	65	130		
Response Time (fall)	Tf	-20℃	—	2000	3500	ms	NOTE 2
		0℃	—	310	580		
		25℃	—	100	220		
		50℃	—	50	120		
		70℃	—	40	105		

AZ Displays, Inc.

5. BLOCK DIAGRAM

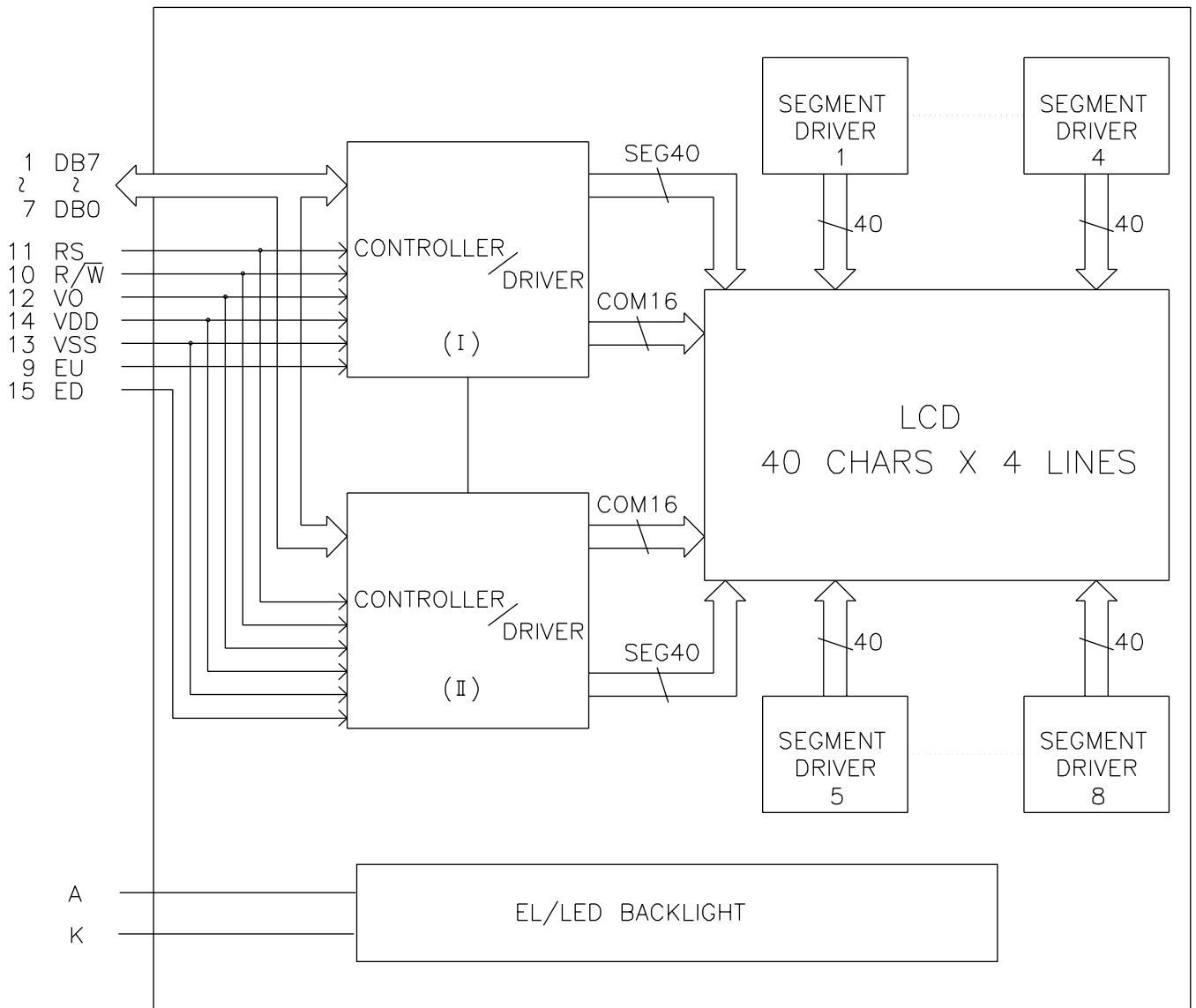

AZ Displays, Inc.

6. INTERNAL PIN CONNECTION

PinNo.	Symbol	Function
1	DB7	Data Bus Line
2	DB6	
3	DB5	
4	DB4	
5	DB3	
6	DB2	
7	DB1	
8	DB0	
9	EU	Enable Signal (Top Panel)
10	R/ \bar{W}	H:Read L:Write
11	RS	H:Data L:Instruction
12	VO	Power Supply for LCD Driving
13	VSS	Power Supply (0V, GND)
14	VDD	Power Supply (+5V)
15	ED	Enable Signal (Bottom Panel)
16	NC	No Connection

AZ Displays, Inc.

7. POWER SUPPLY

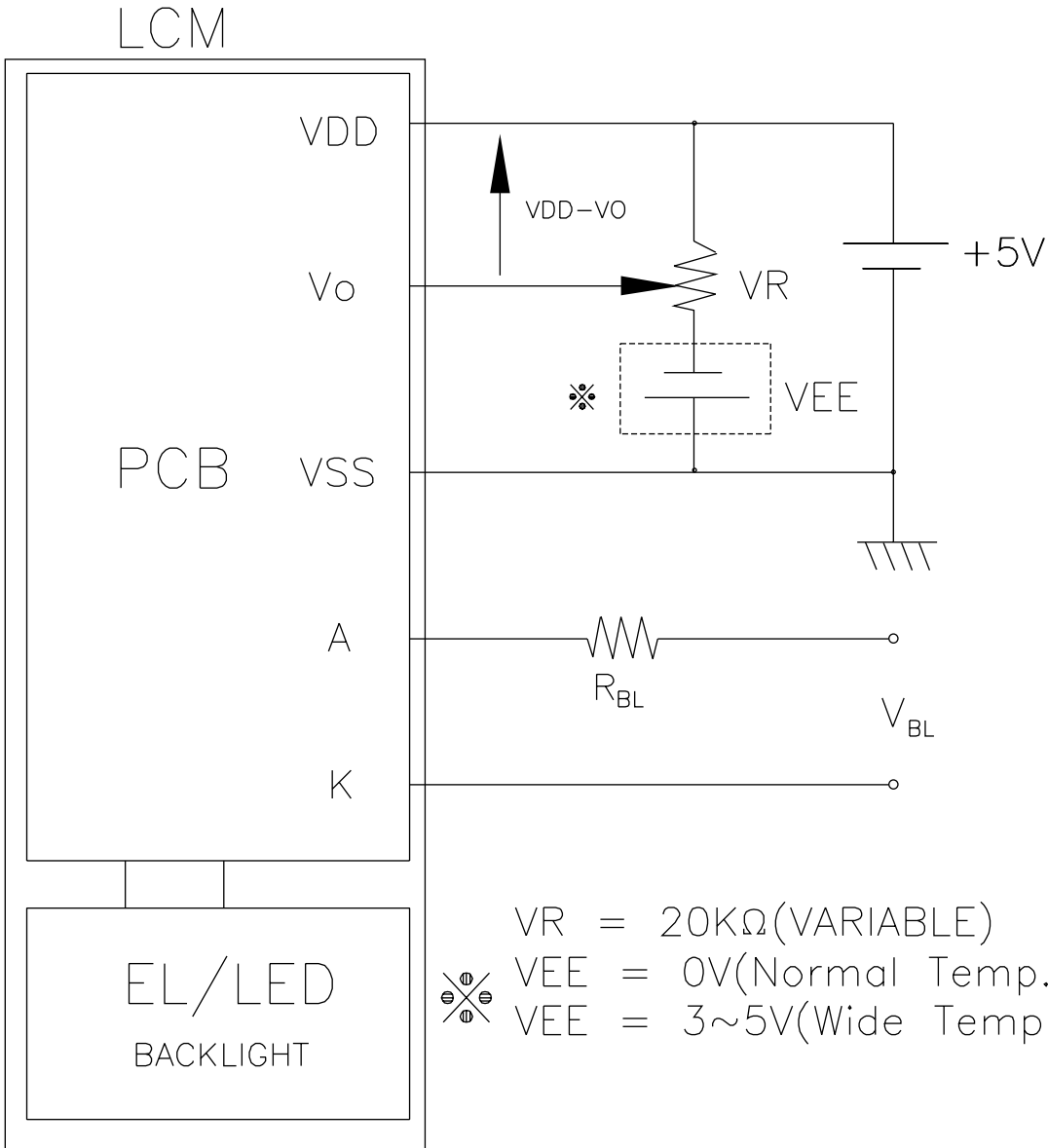

Recommended Value for R_{BL} and V_{BL}

ITEM Back Light	R _{BL}		V _{BL}	
	LED	EL	LED	EL
Interface				
A,K PAD	5Ω	0Ω	5V _{DC}	110V _{AC} 400Hz

AZ Displays, Inc.

8. INTERFACE TIMING CHARACTERISTICS

Item	Symbol	Test condition	Min.	Typ.	Max.	Unit
Enable cycle time	t_{cyc}	Fig.a, Fig.b	500	-	-	ns
Enable pulse width	PW_{EH}	Fig.a, Fig.b	230	-	-	ns
Enable rise/fall time	t_{Er}, t_{Ef}	Fig.a, Fig.b	-	-	25	ns
RS,R/ \bar{W} set up time	t_{AS}	Fig.a, Fig.b	40	-	-	ns
Data delay time	t_{DDR}	Fig.b	-	-	160	ns
Data set up time	t_{DSW}	Fig.a	80	-	-	ns
Hold time	t_H	Fig.a, Fig.b	20	-	-	ns

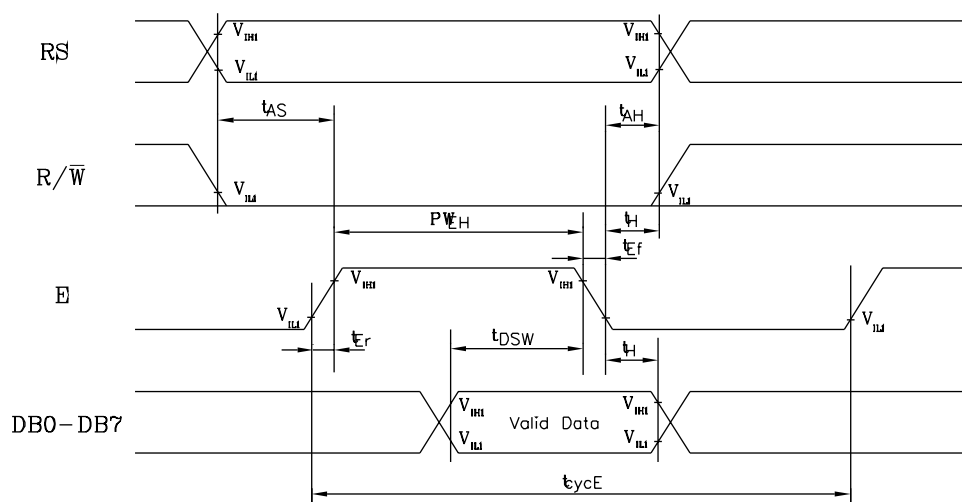

Fig. a Interface timing (data write)

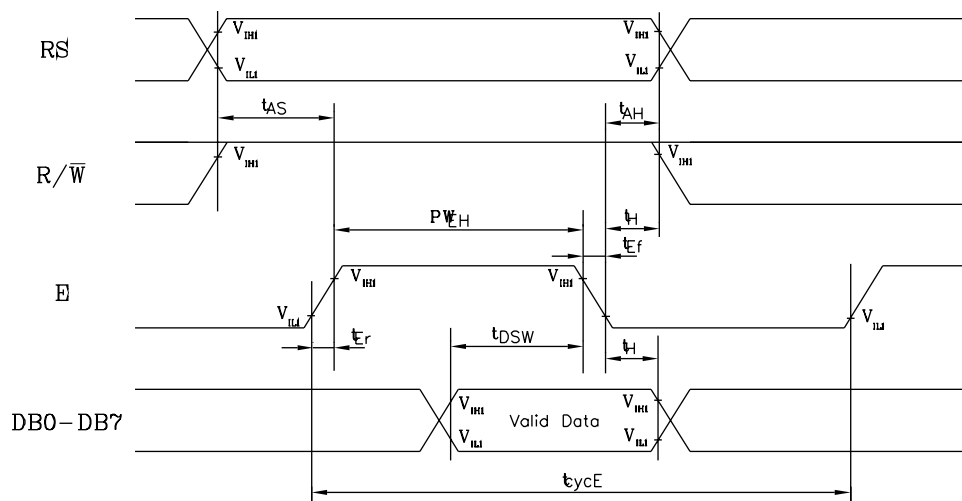

Fig. b Interface timing (data read)

AZ Displays, Inc.

CONTROL and DISPLAY COMMAND

COMMAND	RS	R/W	DB ₇	DB ₆	DB ₅	DB ₄	DB ₃	DB ₂	DB ₁	DB ₀	EXECUTION TIME (FOSC=250kHz)	REMARK															
DISPLAY CLEAR	L	L	L	L	L	L	L	L	L	H	1.64ms																
RETURN HOME	L	L	L	L	L	L	L	L	H	X	1.64ms	CURSOR MOVE TO FIRST DIGIT															
ENTRY MODE SET	L	L	L	L	L	L	L	H	I/D	SH	40μS	<ul style="list-style-type: none"> I/D: SET CURSOR MOVE DIRECTION <table border="1"> <tr> <td rowspan="2">I/D</td> <td>H</td> <td>INCREASE</td> </tr> <tr> <td>L</td> <td>DECREASE</td> </tr> </table> <ul style="list-style-type: none"> SH: SPECIFIES SHIFT OF DISPLAY <table border="1"> <tr> <td rowspan="2">SH</td> <td>H</td> <td>DISPLAY IS SHIFTED</td> </tr> <tr> <td>L</td> <td>DISPLAY IS NOT SHIFTED</td> </tr> </table>	I/D	H	INCREASE	L	DECREASE	SH	H	DISPLAY IS SHIFTED	L	DISPLAY IS NOT SHIFTED					
I/D	H	INCREASE																									
	L	DECREASE																									
SH	H	DISPLAY IS SHIFTED																									
	L	DISPLAY IS NOT SHIFTED																									
DISPLAY ON/OFF	L	L	L	L	L	L	H	D	C	B	40μS	<ul style="list-style-type: none"> DISPLAY <table border="1"> <tr> <td rowspan="2">D</td> <td>H</td> <td>DISPLAY ON</td> </tr> <tr> <td>L</td> <td>DISPLAY OFF</td> </tr> </table> <ul style="list-style-type: none"> CURSOR <table border="1"> <tr> <td rowspan="2">C</td> <td>H</td> <td>CURSOR ON</td> </tr> <tr> <td>L</td> <td>CURSOR OFF</td> </tr> </table> <ul style="list-style-type: none"> BLINKING <table border="1"> <tr> <td rowspan="2">B</td> <td>H</td> <td>BLINKING ON</td> </tr> <tr> <td>L</td> <td>BLINKING OFF</td> </tr> </table>	D	H	DISPLAY ON	L	DISPLAY OFF	C	H	CURSOR ON	L	CURSOR OFF	B	H	BLINKING ON	L	BLINKING OFF
D	H	DISPLAY ON																									
	L	DISPLAY OFF																									
C	H	CURSOR ON																									
	L	CURSOR OFF																									
B	H	BLINKING ON																									
	L	BLINKING OFF																									
SHIFT	L	L	L	L	L	H	S/C	R/L	X	X	40μS	<table border="1"> <tr> <td rowspan="2">SC</td> <td>H</td> <td>DISPLAY SHIFT</td> </tr> <tr> <td>L</td> <td>CURSOR MOVE</td> </tr> </table> <table border="1"> <tr> <td rowspan="2">R/L</td> <td>H</td> <td>RIGHT SHIFT</td> </tr> <tr> <td>L</td> <td>LEFT SHIFT</td> </tr> </table>	SC	H	DISPLAY SHIFT	L	CURSOR MOVE	R/L	H	RIGHT SHIFT	L	LEFT SHIFT					
SC	H	DISPLAY SHIFT																									
	L	CURSOR MOVE																									
R/L	H	RIGHT SHIFT																									
	L	LEFT SHIFT																									
SET FUNCTION	L	L	L	L	H	DL	N	F	X	X	40μS	<table border="1"> <tr> <td rowspan="2">DL</td> <td>H</td> <td>8 DITS INTERFACE</td> </tr> <tr> <td>L</td> <td>4 BITS INTERFACE</td> </tr> </table> <table border="1"> <tr> <td rowspan="2">N</td> <td>H</td> <td>2 LINE DISPLAY</td> </tr> <tr> <td>L</td> <td>1 LINE DISPLAY</td> </tr> </table> <table border="1"> <tr> <td rowspan="2">F</td> <td>H</td> <td>5 X 10 DOTS</td> </tr> <tr> <td>L</td> <td>5 X 7 DOTS</td> </tr> </table>	DL	H	8 DITS INTERFACE	L	4 BITS INTERFACE	N	H	2 LINE DISPLAY	L	1 LINE DISPLAY	F	H	5 X 10 DOTS	L	5 X 7 DOTS
DL	H	8 DITS INTERFACE																									
	L	4 BITS INTERFACE																									
N	H	2 LINE DISPLAY																									
	L	1 LINE DISPLAY																									
F	H	5 X 10 DOTS																									
	L	5 X 7 DOTS																									
SET CG RAM ADDRESS	L	L	L	H	CG RAM address (corresponds to cursor address)					40μS	CG RAM Data is sent and received after this setting																
SET DD RAM ADDRESS	L	L	H	DD RAM address					40μS	DD RAM Data is sent and received after this setting																	
READ BUSY FLAG & ADDRESS	L	H	BF	Address Counter used for Both DD & CG RAM address					0μS	<table border="1"> <tr> <td rowspan="2">BF</td> <td>H</td> <td>Busy</td> </tr> <tr> <td>L</td> <td>Ready</td> </tr> </table> <ul style="list-style-type: none"> -Reads BF indication internal operating is being performed. -reads address counter contents 	BF	H	Busy	L	Ready												
BF	H	Busy																									
	L	Ready																									
WRITE DATA	H	L	Write Data					46μS	Write data into DD or CG RAM																		
READ DATA	H	H	Read Data					46μS	Read data form DD or CGRAM																		

X : Don't care

AZ Displays, Inc.

DISPLAY PATTERN

Display Data RAM address

		1	2	16	17	32	33	39	40
Top Panel (EU Control)	1st line	00	01	0F	10	1F	20	26	27
	2nd line	40	41	4F	50	5F	60	66	67
Bottom Panel (ED Control)	3rd line	00	01	0F	10	1F	20	26	27
	4th line	40	41	4F	50	5F	60	66	67

40 x 4 Display Pattern

AZ Displays, Inc.

(NOTE 4)

Definition of Viewing Direction

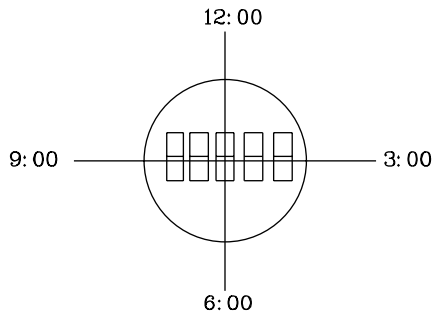

(NOTE 5)

Definition of Viewing Angle

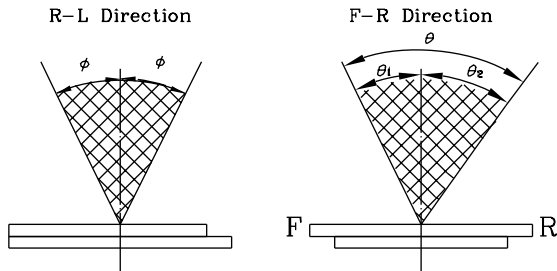

$$\theta = \theta_1 + \theta_2$$

*Conditions

- Operating Voltage : Vop
- Frame Frequency : 70Hz
- Applying Waveform : 1/N duty 1/a bias
- Contrast Ratio : larger than 2

(NOTE 6)

Definition of Contrast Ratio (Cr)

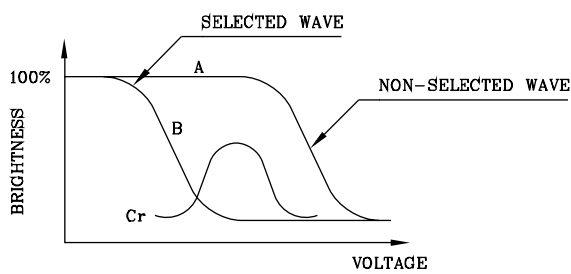

(positive type)

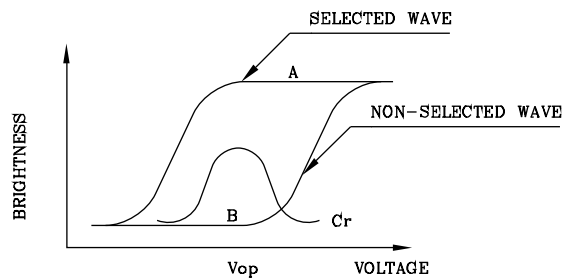

(negative type)

$$\text{Contrast Ratio : } Cr = A/B$$

*Conditions

- Viewing Angle : 0
- Frame Frequency : 70Hz
- Applying Waveform : 1/N duty 1/a bias

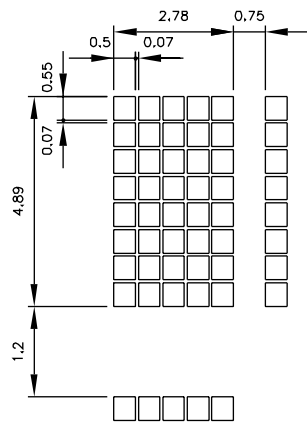
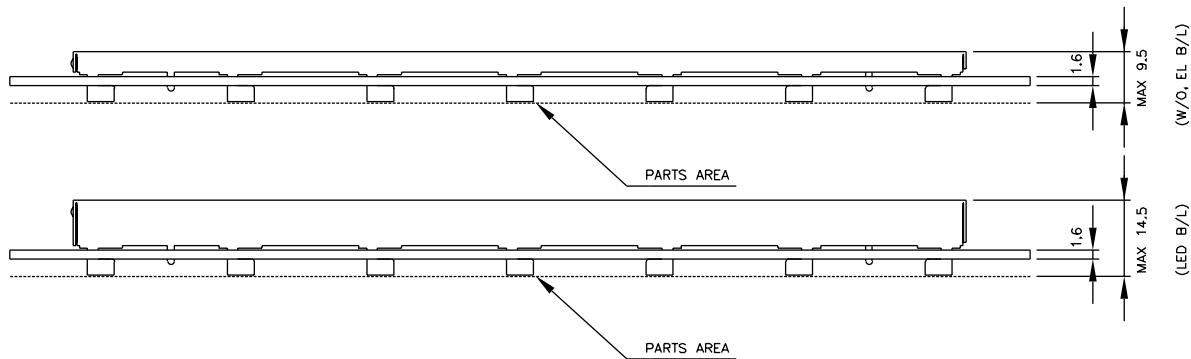
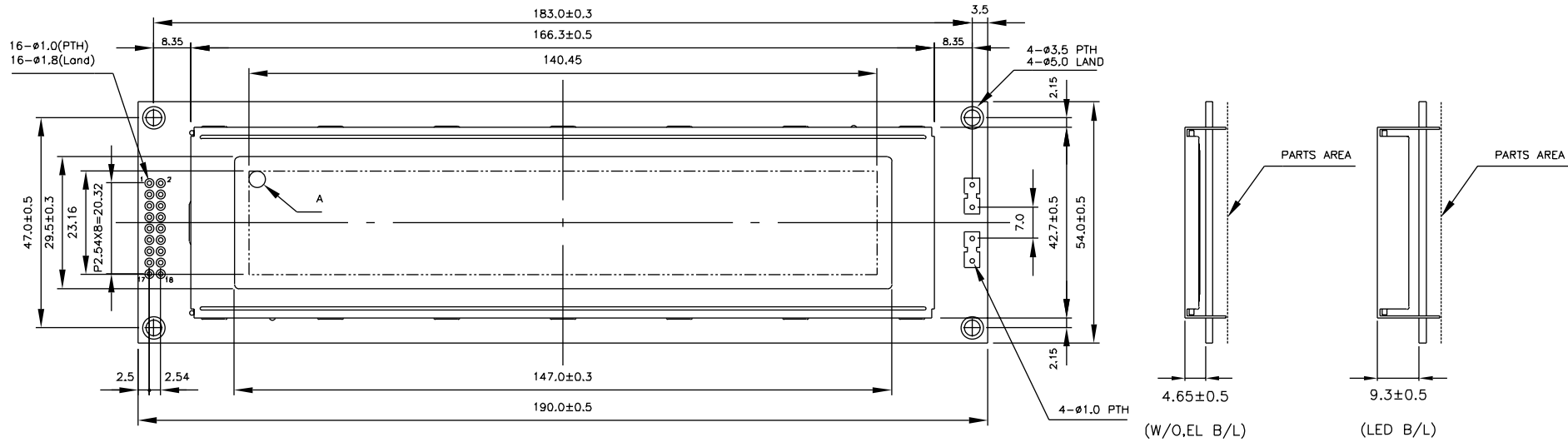

A DETAIL

NOTES :

1. RESOLUTION: 40 CHARACTERS X 4 LINES

PinNo.	Symbol	Function
1	DB7	Data Bus Line
2	DB6	
3	DB5	
4	DB4	
5	DB3	
6	DB2	
7	DB1	
8	DB0	
9	EU	Enable Signal (Top panel)
10	R/W	H:Read L:Write
11	RS	H:Data L:Instruction
12	VO	Power Supply for LCD Driving
13	VSS	Power Supply (0V, GND)
14	VDD	Power Supply (+5V)
15	ED	Enable Signal (Bottom panel)
16	NC	No Connection
17	A	Power Supply for EL/LED B/L
18	K	Power Supply for EL/LED B/L

ACM4004C		AZ DISPLAYS, INC.		
APPROVE	NAME	DATE	TITLE	
CHECK			DWG-NO	MX-X028X5 Rev.A
DESIGN				
DRAW	MAY PING	88.07.22		
			UNIT : mm	
			SCALE : 1/1	

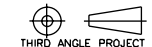

THIRD ANGLE PROJECT