

AZ DISPLAYS, INC

Complete LCD Solutions

ACM4004D SERIES LCD MODULE

1.0 PHYSICAL DATA

Item	Nominal Dimensions / Available Options	Unit
Number of Characters	40 characters x 4 lines	-
Character Format	5 x 7 dots with cursor	-
Overall Module Size (W x H x D)	190.0 x 54.0 x max 13.0 for LED backlight version 190.0 x 54.0 x max 8.8 for reflective or EL backlight version	mm
Dot Size (W x H)	0.50 x 0.55	mm
Dot Pitch (W x H)	0.57 x 0.62	mm
Duty	1/16	-
Controller IC	KS0066	-
LC Fluid Options	TN, STN	-
Polarizer Options	Reflective, Transflective, Transmissive	-
Backlight Options	EL, LED	-
Temperature Range Options	Standard, Wide temp	-

2.0 ABSOLUTE MAXIMUM RATINGS

Item	Symbol	Min	Typ	Max	Unit
Operating temperature (Standard)	Top	0	-	50	°C
Storage temperature (Standard)	Tst	-20	-	70	°C
Operating temperature (Wide temp)	Top	-20	-	+70	°C
Storage temperature (Wide temp)	Tst	-30	-	+80	°C
Input voltage	V _I	V _{SS}	-	V _{DD}	V
Supply voltage for logic	V _{DD} -V _{SS}	0	5.0	6.5	V
Supply voltage for LCD drive (Standard)	V _{DD} -V _O	0	-	6.5	V
Supply voltage for LCD drive (Wide temp)	V _{DD} -V _O	0	-	13.5	V

3.0 OPTICAL CHARACTERISTICS (T_a = 25C, V_{DD} = 5.0V +/- 0.25V, STN Fluid)

Item	Symbol	Condition	Min	Typ	Max	Unit
Viewing angle (horizontal)	θ	Cr \geq 2.0	-	\pm 30	-	deg
Viewing angle (vertical)	ϕ	Cr \geq 2.0	-	40	-	deg
Contrast Ratio	Cr	$\phi=0^\circ, \theta=0^\circ$	-	3.0	-	
Response time (rise)	T _r	$\phi=0^\circ, \theta=0^\circ$	-	120	240	ms
Response time (fall)	T _f	$\phi=0^\circ, \theta=0^\circ$	-	155	310	ms

ACM4004D SERIES LCD MODULE

4.0 ELECTRICAL CHARACTERISTICS (Ta = 25°C, VDD = 5.0V +/- 0.25V)

Item	Symbol	Condition	Min	Typ	Max	Unit
Supply voltage for LCD drive (Std temp)	VDD-Vo	Ta = 25°C		4.5		V
Supply voltage for LCD drive (Wide temp)	VDD-Vo	Ta = 25°C		6.2		V
Input voltage	VI	-	4.75	5.0	5.25	V
Input high voltage	VIH	-	0.8VDD	VDD	-	V
Input low voltage	VIL	-	VSS	0.2VDD	-	V
Supply current	IDD	VDD=5.0V	-	6.0	10.0	mA
LED power supply current	ILED	Vf=4.2V	-	600	-	mA

5.0 INTERFACE PIN CONNECTIONS

Pin No.	Symbol	Level	Pin Description	Function
1	DB7	H/L	Data bit 7	4-bit or 8-bit interface
2	DB6	H/L	Data bit 6	4-bit or 8-bit interface
3	DB5	H/L	Data bit 5	4-bit or 8-bit interface
4	DB4	H/L	Data bit 4	4-bit or 8-bit interface
5	DB3	H/L	Data bit 3	8-bit interface
6	DB2	H/L	Data bit 2	8-bit interface
7	DB1	H/L	Data bit 1	8-bit interface
8	DB0	H/L	Data bit 0	8-bit interface
9	E1	H, H→L	Enable for IC1	Start signal for data read/write
10	R/W	H/L	Read / write	H: Data read, L: Data write
11	RS	H/L	Register Select	H: Data; L: Instruction code
12	Vo	-	LCD Contrast Adjustment	By user
13	VSS	0V	Ground	0V
14	VDD	5V	Supply Voltage for logic	5V
15	E2	H, H→L	Enable for IC2	Start signal for data read/write
16	NC	-	No Connection	None
17	A	4.2V	Anode for LED backlight	Power supply for LED/EL backlights
18	K	0V	Cathode for LED backlight	Power supply for LED/EL backlights

ACM4004D SERIES LCD MODULE

6.0 POWER SUPPLY

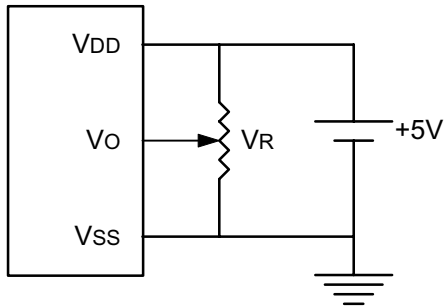

Standard temp range

$V_R = 10K\Omega \sim 20K\Omega$

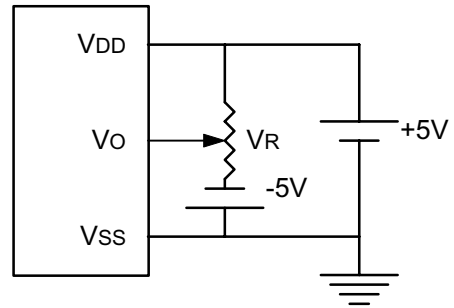

Wide temp range

$V_R = 10K\Omega \sim 20K\Omega$

7.0 BLOCK DIAGRAM

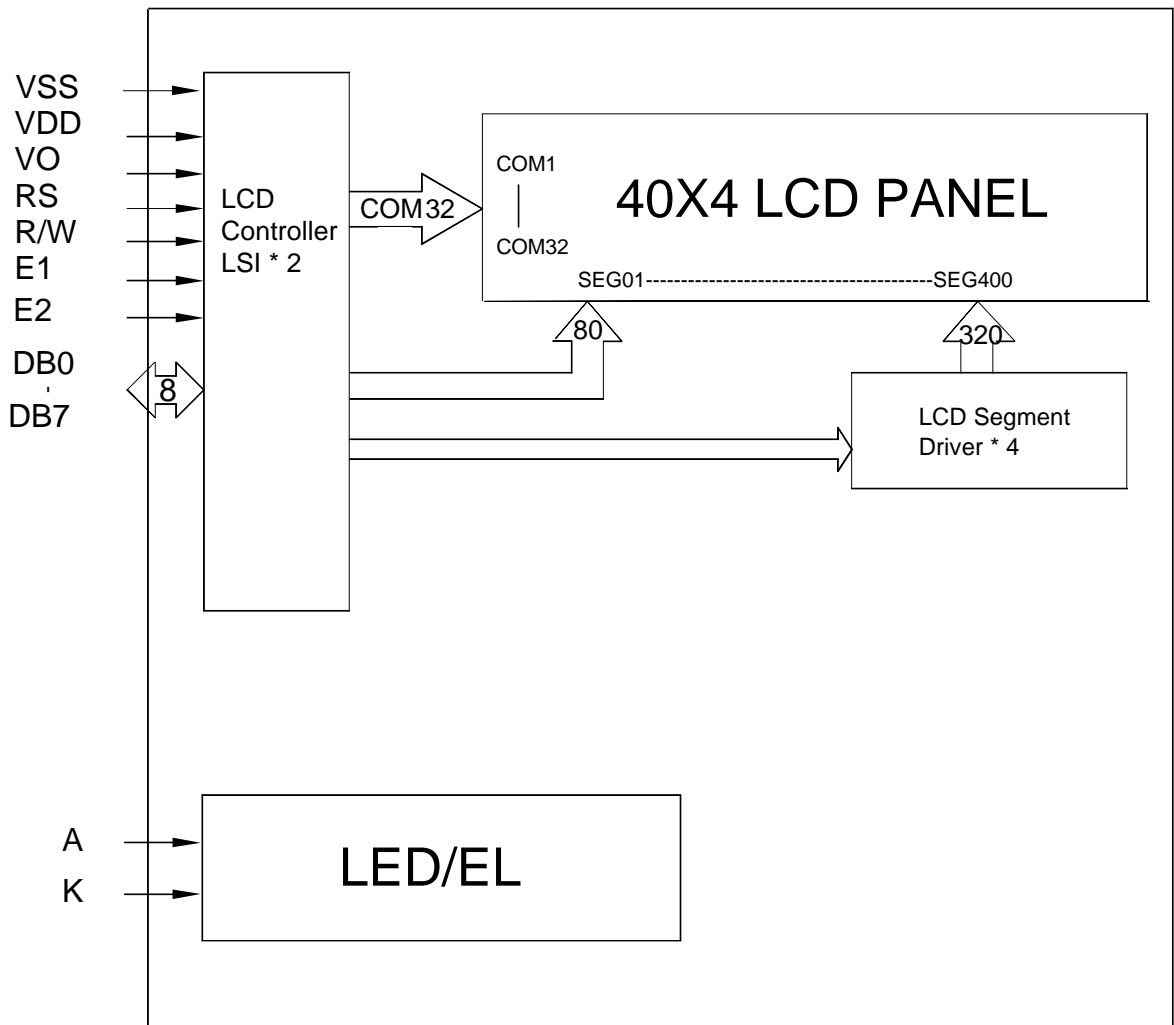

ACM4004D SERIES LCD MODULE

8.0 TIMING CHARACTERISTICS (KS0066 Controller)

Item	Symbol	Test Condition	Min.	Typ.	Max.	Unit
Enable cycle time	t_{CYC}	Fig. a, Fig. b	500	-	-	ns
Enable pulse width	PW_{EH}	Fig. a, Fig. b	220	-	-	ns
Enable rise/fall time	t_{Er} , t_{Ef}	Fig. a, Fig. b	-	-	25	ns
RS, R/W set up time	t_{AS}	Fig. a, Fig. b	40	-	-	ns
RS, R/W hold time	t_{H1}	Fig. a, Fig. b	10	-	-	ns
Data set up time	t_{DSW}	Fig. a	60	-	-	ns
Data hold time	t_{H2}	Fig. a	10	-	-	ns
Data delay time	t_{DDR}	Fig. b	-	-	120	ns
Data hold time	t_{H2}	Fig. b	20	-	-	ns

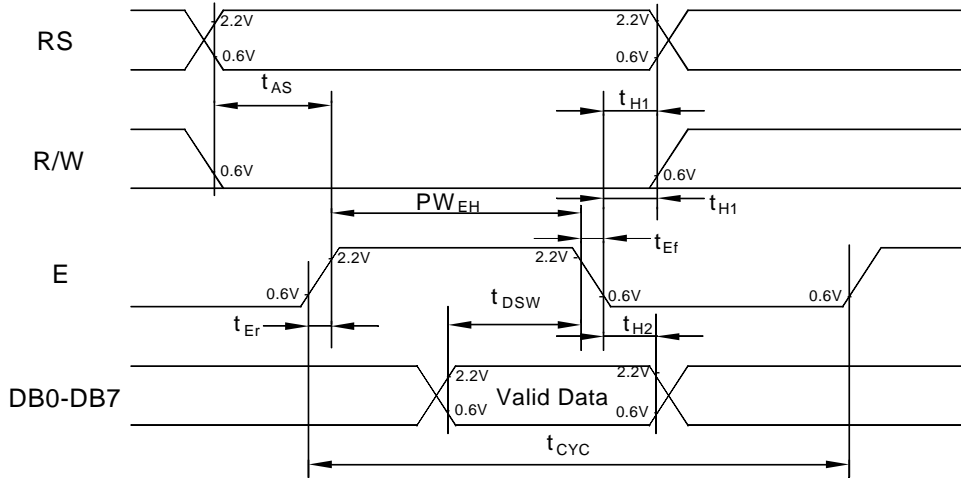

Fig. a Interface timing (data write)

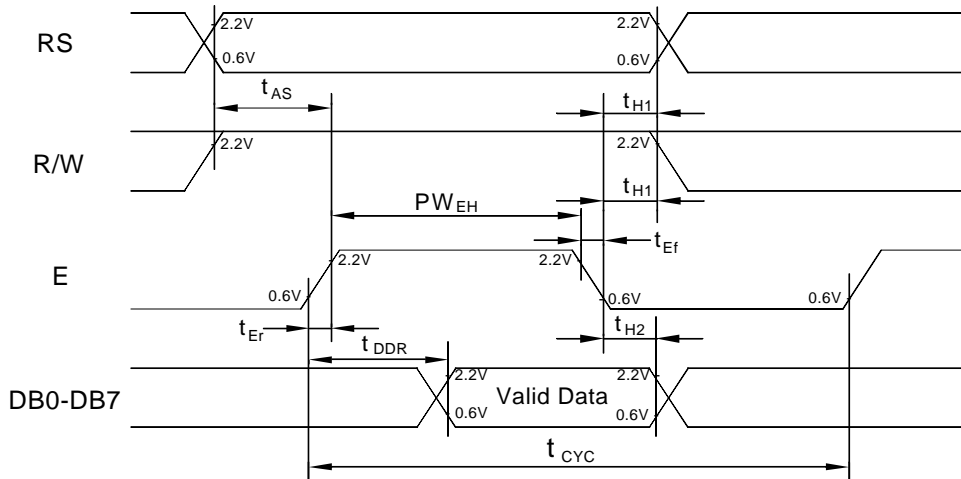
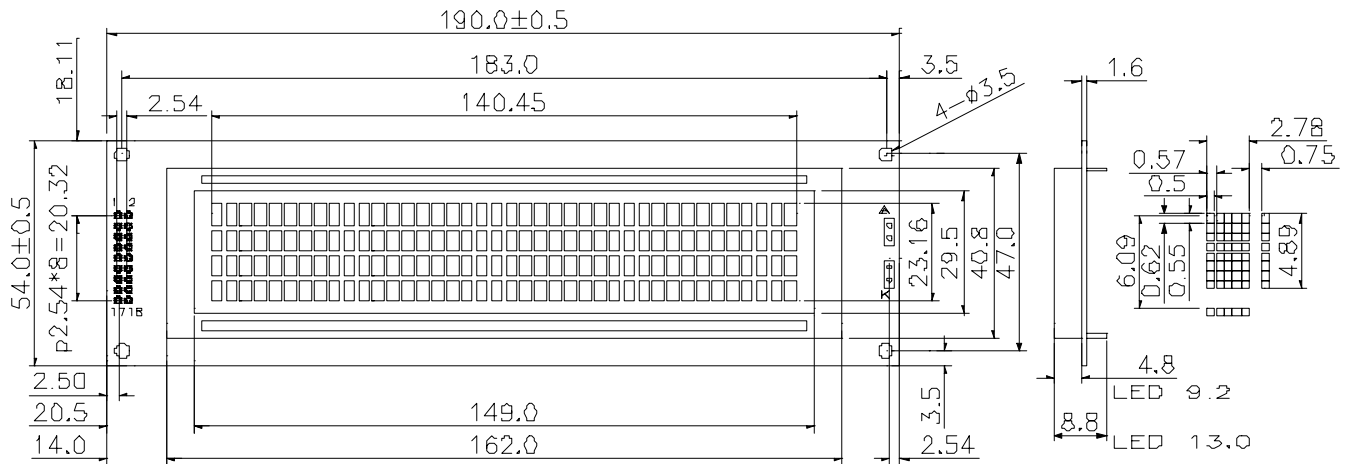

Fig. b Interface timing (data read)



1.	DB7	5.	DB3	9.	E1	13.	VSS	17.	A(+)
2.	DB6	6.	DB2	10.	R/W	14.	VDD	18.	K(-)
3.	DB5	7.	DB1	11.	RS	15.	E2		
4.	DB4	8.	DB0	12.	Vo	16.	NC		

Unless otherwise specified, Tolerance: +/- 0.3mm

CUSTOMER APVL				DATE		TITLE		REV	
DWN	Karin	DATE	2000.12.01	SCALE	1/1	MODULE			1
CHKD	Hsu	DATE		UNIT	mm	MODEL			
APVD	Lin	DATE				ACM4004D			
AZ DISPLAYS, INC.						DWG NO	SC-0042	PAGE	1/1