

# Data Sheet

## Description

The new ACNV260E is an optically coupled gate that combines a AlGaAs light emitting diode and an integrated photo detector housed in a widebody package. ACNV260E is designed and manufactured to comply with EN60079-11 ATEX and IECEx. The distance-through-insulation (DTI) between the emitting diode and photo-detector is at 2mm. The output of the detector IC is an open collector Schottky clamped transistor. The internal shield provides a guaranteed common mode transient immunity specification of 20,000 V/μs at  $V_{cm} = 1500V$

This unique design provides maximum ac and dc circuit isolation while achieving TTL compatibility.

The new ACNV260E is suitable for high speed logic interfacing, input/output buffering, as line receivers in environments that conventional line receivers cannot tolerate and are recommended for use in extremely high ground or induced noise environments.

## Functional Diagram

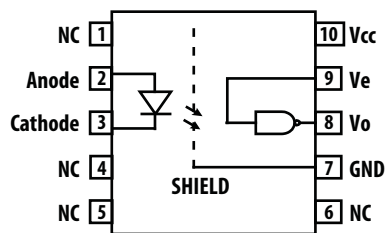

**Truth Table  
(Positive Logic)**

LED	ENABLE	OUTPUT
On	H	L
Off	H	H
On	L	H
Off	L	H
On	NC	L
Off	NC	H

A 0.1 μF bypass capacitor must be connected between pins  $V_{CC}$  and GND.

## Features

- Compliant to EN60079-11 ATEX and IECEx (375V)
- 2mm DTI
- 13mm creepage and clearance
- 20 kV/μs Minimum Common Mode Rejection (CMR) at  $V_{CM} = 1500V$
- High Speed: 10 MBd Typical
- TTL Compatible
- Guaranteed ac and dc performance over temperature: -40°C to +105°C
- Available in 10-Pin widebody packages
- Safety Approval
  - Approval at 5000 Vrms for 1 minute per UL1577
  - CSA

## Applications

- High Voltage insulation
- Intrinsic safety circuit
- PCB Board Power System Isolation
- Industrial Equipment Power Isolation

**CAUTION:** It is advised that normal static precautions be taken in handling and assembly of this component to prevent damage and/or degradation which may be induced by ESD.

## Ordering Information

ACNV260E is UL Recognized with 5000 Vrms for 1 minute per UL1577.

Part number	Option	Package	Surface Mount			UL 5000 V <sub>rms</sub> / 1 Minute rating	Quantity
	RoHS Compliant		Mount	Gull Wing	Tape & Reel		
ACNV260E	-000E	500 mil DIP-10				X	35 per tube
	-300E		X	X		X	35 per tube
	-500E	X	X	X	X	500 per reel	

To order, choose a part number from the part number column and combine with the desired option from the option column to form an order entry.

### Example 1:

ACNV260E-500E to order product of 500mil DIP-10 Widebody with Gull Wing Surface Mount package in Tape and Reel packaging with UL 5000Vrms/1min Safety Approval in RoHS compliant.

Option datasheets are available. Contact your Avago sales representative or authorized distributor for information.

### Schematic

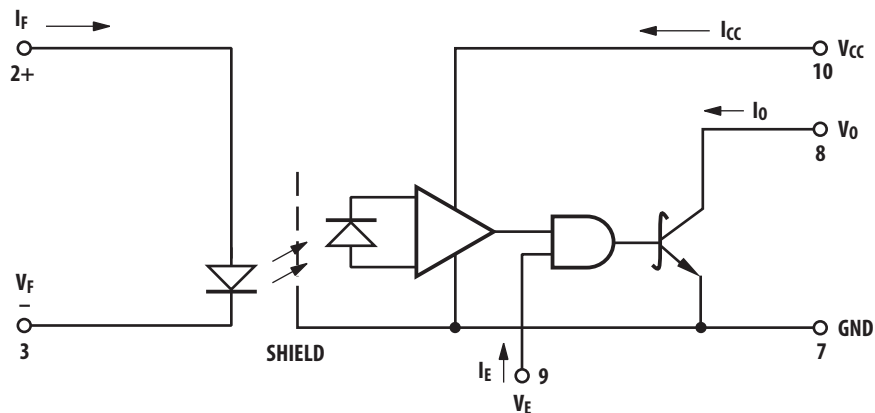

Use of a 0.1 $\mu$ F bypass capacitor connected between pins of 7 and 10 is recommended (see note 5).

### 10-Pin Widebody (500mils) DIP Package

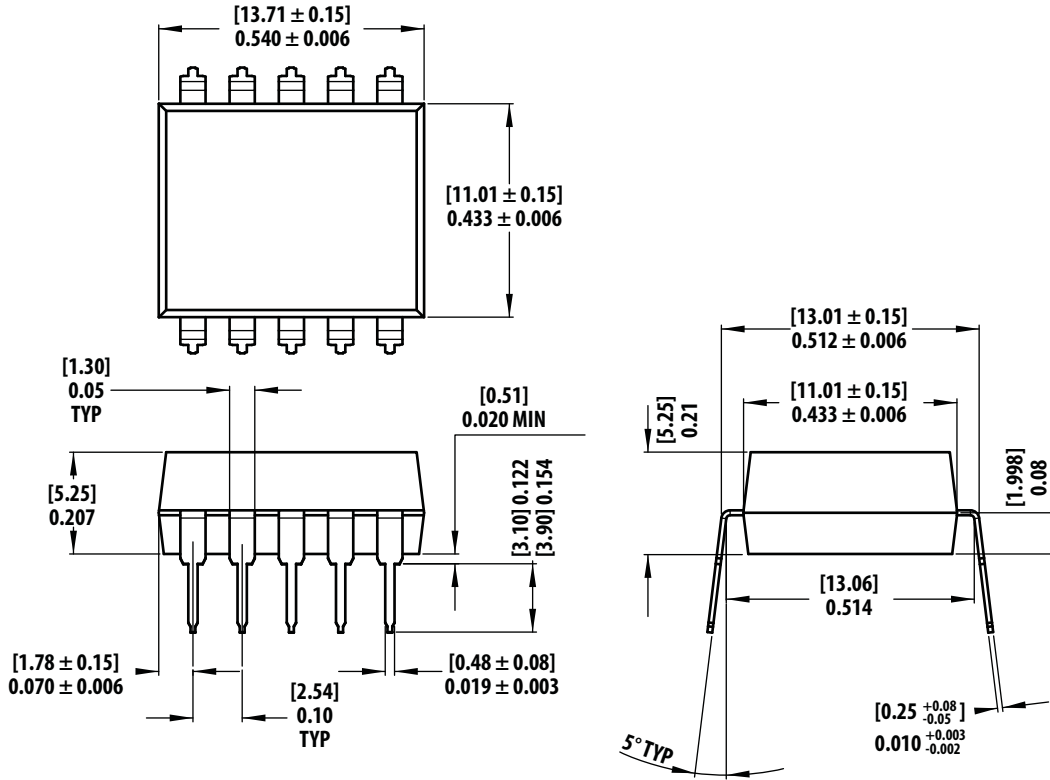

### 10-Pin Widebody (500mils) DIP Package with Gull Wing Surface Mount Option 300

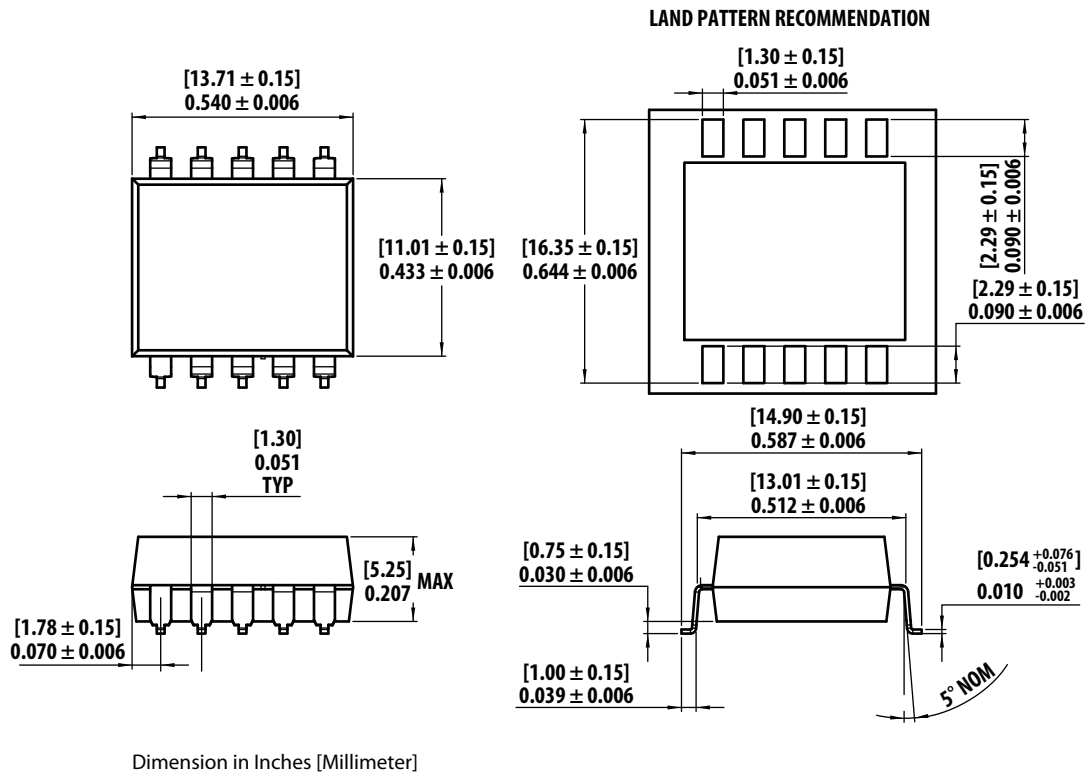

## Solder Reflow Profile

Recommended reflow condition as per JEDEC Standard, J-STD-020 (latest revision). Non-Halide Flux should be used.

### Insulation and Safety Related Specifications

Parameter	Symbol	ACNV260E	Units	Conditions
Minimum External Air Gap (External Clearance)	L(101)	13	mm	Measured from input terminals to output terminals, shortest distance through air.
Minimum External Tracking (External Creepage)	L(102)	13	mm	Measured from input terminals to output terminals, shortest distance path along body.
Minimum Internal Plastic Gap (Internal Clearance)		2.0	mm	Through insulation distance conductor to conductor, usually the straight line distance thickness between the emitter and detector.
Minimum Internal Tracking (Internal Creepage)		4.6	mm	Measured from input terminals to output terminals, along internal cavity.
Tracking Resistance (Comparative Tracking Index)	CTI	200	V	DIN IEC 112/VDE 0303 Part 1.
Maximum Working Insulation Voltage	V <sub>IORM</sub>	375	V <sub>peak</sub>	Per IEC 60079-11.
Safety-limiting values – maximum values allowed in the event of a failure.				
Case Temperature	T <sub>S</sub>	150	°C	
Input Current**	I <sub>S, INPUT</sub>	400	mA	
Output Power**	P <sub>S, OUTPUT</sub>	1	W	
Insulation Group		IIIa		Material Group (DIN VDE 0110, 1/89, Table 1).

### Absolute Maximum Ratings

Parameter	Symbol	Min.	Max.	Units
Storage Temperature	T <sub>S</sub>	-55	125	°C
Operating Temperature	T <sub>A</sub>	-40	105	°C
Average Input Current	I <sub>F(AVG)</sub>		20	mA
Reverse Input Voltage	V <sub>R</sub>		3	V
Input Power Dissipation	P <sub>I</sub>		40	mW
Supply Voltage (1 Minute Maximum)	V <sub>CC</sub>		7	V
Enable Input Voltage (Not to Exceed V <sub>CC</sub> by more than 500mV)	V <sub>E</sub>		V <sub>CC</sub> +0.5	V
Enable Input Current	I <sub>E</sub>		5	mA
Output Collector Current	I <sub>O</sub>		50	mA
Output Collector Voltage	V <sub>O</sub>		7	V
Output Collector Power Dissipation	P <sub>O</sub>		85	mW
Lead Solder Temperature	T <sub>LS</sub>		245°C for 10 sec, up to seat plane	
Solder Reflow Temperature Profile				See Package Outline Drawings section

## Recommended Operating Conditions

Parameter	Symbol	Min.	Max.	Units	Note
Input Current, Low Level	$I_{FL}^*$	0	250	$\mu\text{A}$	
Input Current, High Level	$I_{FH}^{**}$	9	16	mA	1
Power Supply Voltage	$V_{CC}$	4.5	5.5	V	
Low Level Enable Voltage	$V_{EL}$	0	0.8	V	
High Level Enable Voltage	$V_{EH}$	2.0	$V_{CC}$	V	
Operating Temperature	$T_A$	-40	105	$^{\circ}\text{C}$	
Fan Out (at $R_L = 1\text{ k}\Omega$ )	N		5	TTL Loads	
Output Pull-up Resistor	$R_L$	330	4k	$\Omega$	

\* The off condition can also be guaranteed by ensuring that  $V_{FL} \leq 0.8\text{ volts}$ .

\*\* The initial switching threshold is 8mA or less. It is recommended that 9mA to 16mA be used for best performance and to permit at least a 20% LED degradation guardband.

## Electrical Specifications (DC)

Over recommended operating conditions unless otherwise specified. All typicals at  $V_{CC} = 5\text{ V}$ ,  $T_A = 25^{\circ}\text{C}$ .

Parameter	Symbol	Min.	Typ.	Max.	Units	Test Conditions	Fig.	Note
High Level Output Current	$I_{OH}$		5.5	100	$\mu\text{A}$	$V_{CC} = 5.5\text{ V}$ , $V_E = 2.0\text{ V}$ $V_O = 5.5\text{ V}$ , $I_{FL} = 250\ \mu\text{A}$		12
Input Threshold Current	$I_{TH}$		3.5	8	mA	$V_{CC} = 5.5\text{ V}$ , $V_E = 2.0\text{ V}$ , $V_O = 0.6\text{ V}$ , $I_{OL} > 13\text{ mA}$	1, 2	12
Low Level Output Voltage	$V_{OL}$		0.35	0.6	V	$V_{CC} = 5.5\text{ V}$ , $V_E = 2.0\text{ V}$ , $I_F = 8\text{ mA}$ , $I_{OL(\text{Sinking})} = 13\text{ mA}$	1, 2, 3, 4	12
High Level Supply Current	$I_{CCH}$		7.0	12	mA	$V_E = 0.5\text{ V}$ $V_{CC} = 5.5\text{ V}$ , $V_E = V_{CC}$ $I_F = 0\text{ mA}$		
Low Level Supply Current	$I_{CCL}$		9.0	13	mA	$V_E = 0.5\text{ V}$ $V_{CC} = 5.5\text{ V}$ , $V_E = V_{CC}$ $I_F = 10\text{ mA}$		
High Level Enable Current	$I_{EH}$		-0.7		mA	$V_{CC} = 5.5\text{ V}$ , $V_E = 2.0\text{ V}$		
Low Level Enable Current	$I_{EL}$		-0.9		mA	$V_{CC} = 5.5\text{ V}$ , $V_E = 0.5\text{ V}$		
High Level Enable Voltage	$V_{EH}$	2.0			mA	$V_{CC} = 5.5\text{ V}$ , $V_E = 2.0\text{ V}$		12
Low Level Enable Voltage	$V_{EL}$			0.8	mA	$V_{CC} = 5.5\text{ V}$ , $V_E = 0.5\text{ V}$		
Input Forward Voltage	$V_F$	1.25	1.64	1.85	V	$T_A = 25^{\circ}\text{C}$ $I_F = 10\text{ mA}$		5
		1.2		2.05				
Input Reverse Breakdown Voltage	$BV_R$	5			V	$I_R = 100\ \mu\text{A}$ , $T_A = 25^{\circ}\text{C}$		
Input Capacitance	$C_{IN}$		60		pF	$f = 1\text{ MHz}$ , $V_F = 0\text{ V}$		
Input Diode Temperature Coefficient	$\Delta V_F / \Delta T_A$		-1.9		mV/ $^{\circ}\text{C}$	$I_F = 10\text{ mA}$		

## Switching Specifications (AC)

Over recommended temperature ( $T_A = -40^\circ\text{C}$  to  $105^\circ\text{C}$ ),  $V_{CC} = 5\text{ V}$ ,  $I_F = 10\text{ mA}$  unless otherwise specified. All typicals are at  $T_A = 25^\circ\text{C}$ ,  $V_{CC} = 5\text{ V}$ .

Parameter	Symbol	Min.	Typ.	Max.	Units	Test Conditions	Fig.	Note
Propagation Delay Time to High Output Level	$t_{PLH}$	30	50	80 120	ns	$T_A = 25^\circ\text{C}$ $R_L = 350\Omega$ , $C_L = 15\text{ pF}$	6, 7, 8	3, 12
Propagation Delay Time to Low Output Level	$t_{PHL}$	35	55	80 120	ns	$T_A = 25^\circ\text{C}$		4, 12
Pulse Width Distortion	$ t_{PHL} - t_{PLH} $		5	40	ns	$R_L = 350\Omega$ , $C_L = 15\text{ pF}$	6, 7, 8, 9	6, 12
Propagation Delay Skew	$t_{psk}$			50	ns			5, 6, 12
Output Rise Time (10%-90%)	$T_r$		25		ns		10	12
Output Fall Time (10%-90%)	$T_f$		10		ns		10	12
Propagation Delay Time of Enable from $V_{EH}$ to $V_{EL}$	$t_{ELH}$		30		ns	$R_L = 350\Omega$ , $C_L = 15\text{ pF}$ , $V_{EL} = 0\text{ V}$ , $V_{EH} = 3\text{ V}$	11, 12	7
Propagation Delay Time of Enable from $V_{EL}$ to $V_{EH}$	$t_{EHL}$		20		ns	$R_L = 350\Omega$ , $C_L = 15\text{ pF}$ , $V_{EL} = 0\text{ V}$ , $V_{EH} = 3\text{ V}$	11, 12	8
Output High Level Common Mode Transient Immunity	$ CM_H $	20	25		kV/ $\mu\text{s}$	$V_{CC} = 5\text{ V}$ , $I_F = 0\text{ mA}$ , $V_{O(MIN)} = 2\text{ V}$ , $R_L = 350\Omega$ , $T_A = 25^\circ\text{C}$ , $V_{CM} = 1500\text{ V}$	13	9, 11, 12
Output Low Level Common Mode Transient Immunity	$ CM_L $	20	25		kV/ $\mu\text{s}$	$V_{CC} = 5\text{ V}$ , $I_F = 10\text{ mA}$ , $V_{O(MAX)} = 0.8\text{ V}$ , $R_L = 350\Omega$ , $T_A = 25^\circ\text{C}$ , $V_{CM} = 1500\text{ V}$		10, 11, 12

## Package Characteristics

All typicals at  $T_A = 25^\circ\text{C}$ .

Parameter	Symbol	Min.	Typ.	Max.	Units	Test Conditions	Fig.	Note
Input-Output Insulation	$V_{ISO}$	5000			$V_{rms}$	$RH < 50\%$ for 1 min. $T_A = 25^\circ\text{C}$		13, 14
Input-Output Resistance	$R_{I-O}$	$10^{12}$			$\Omega$	$V_{I-O} = 500\text{ V}$		13
Input-Output Capacitance	$C_{I-O}$		0.5	0.6	pF	$f = 1\text{ MHz}$ , $T_A = 25^\circ\text{C}$		13

Notes:

- Peaking circuits may produce transient input currents up to 50mA, 50ns maximum pulse width, provided average current does not exceed 20mA.
- By passing of power supply line is required, with a  $0.1\mu\text{F}$  ceramic disc capacitor adjacent to each optocoupler as illustrated in Figure 15. Total lead length between both ends of the capacitor and the isolator pins should not exceed 20mm.
- The  $t_{PLH}$  propagation delay is measured from the 5 mA point on the falling edge of the input pulse to the 1.5 V point on the rising edge of the output pulse.
- The  $t_{PHL}$  propagation delay is measured from the 5 mA point on the rising edge of the input pulse to the 1.5 V point on the falling edge of the output pulse.
- $t_{psk}$  is equal to the worst case difference in  $t_{PHL}$  and/or  $t_{PLH}$  that will be seen between units at any given temperature and specified test conditions.
- See application section titled "Propagation Delay, Pulse-Width Distortion and Propagation Delay Skew" for more information.
- The  $t_{ELH}$  enable propagation delay is measured from the 1.5 V point on the falling edge of the enable input pulse to the 1.5 V point on the rising edge of the output pulse.
- The  $t_{EHL}$  enable propagation delay is measured from the 1.5 V point on the rising edge of the enable input pulse to the 1.5 V point on the falling edge of the output pulse.
- $CM_H$  is the maximum tolerable rate of rise of the common mode voltage to assure that the output will remain in a high logic state (i.e.,  $V_O > 2.0\text{ V}$ ).
- $CM_L$  is the maximum tolerable rate of fall of the common mode voltage to assure that the output will remain in a low logic state (i.e.,  $V_O < 0.8\text{ V}$ ).
- For sinusoidal voltages,  $(dV_{CM} / dt)_{max} = \pi f_{CM} V_{CM(p-p)}$ .
- No external pull up is required for a high logic state on the enable input. If the  $V_E$  pin is not used, tying  $V_E$  to  $V_{CC}$  will result in improved  $CM_R$  performance.
- Device considered a two-terminal device: pins 1, 2, 3, 4 and 5 shorted together, and pins 6, 7, 8, 9 and 10 shorted together.
- In accordance with UL1577, each optocoupler is proof tested by applying an insulation test voltage  $\geq 6000 V_{rms}$  for one second (leakage detection current limit,  $I_{I-O} \leq 5\text{ }\mu\text{A}$ ).

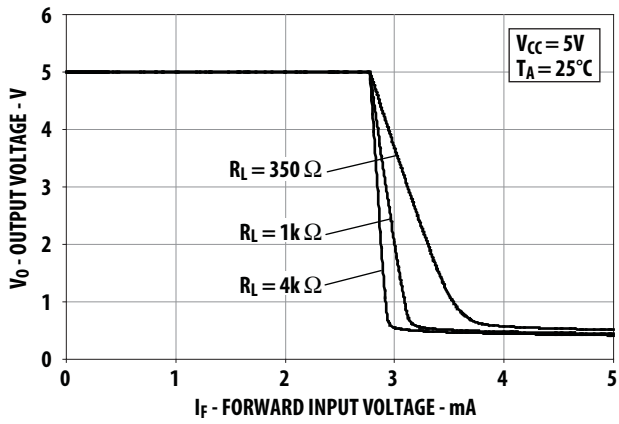

Figure 1. Typical output voltage vs. forward input voltage current.

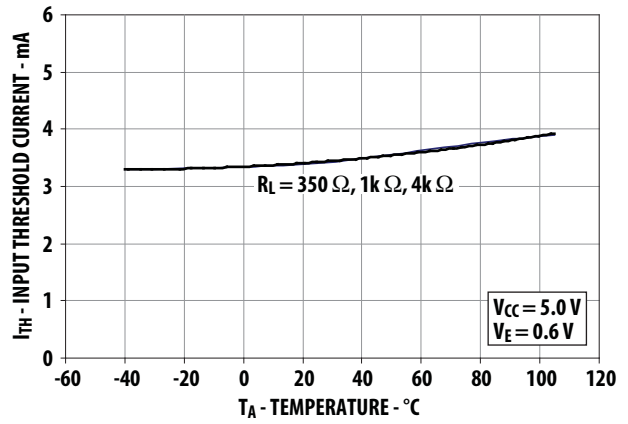

Figure 2. Typical input threshold current vs. temperature.

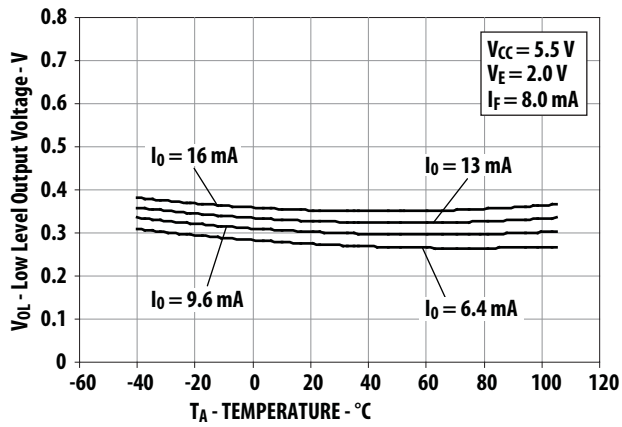

Figure 3. Typical low level output voltage vs. temperature.

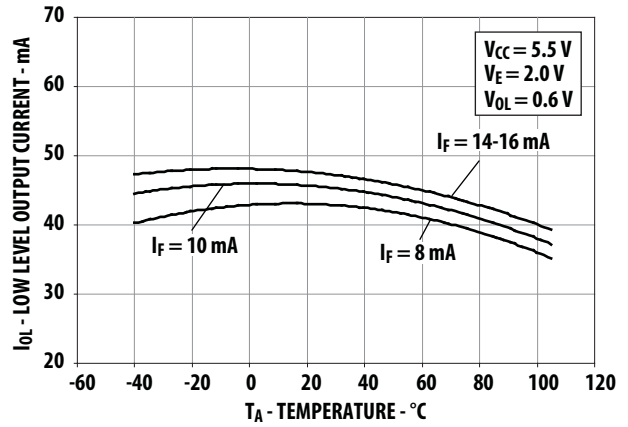

Figure 4. Typical low level output current vs. temperature.

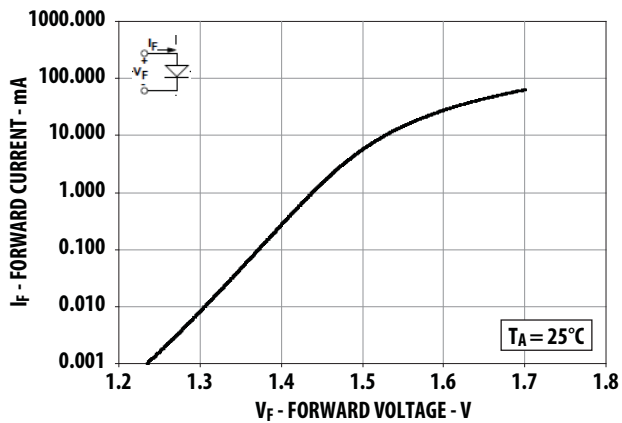

Figure 5. Typical input diode forward characteristic.

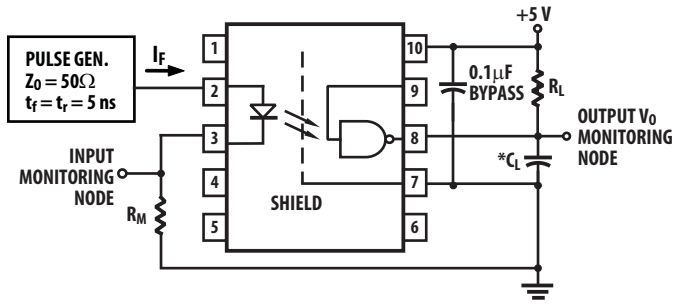

Figure 6. Test circuit for  $t_{pHL}$  and  $t_{pLH}$

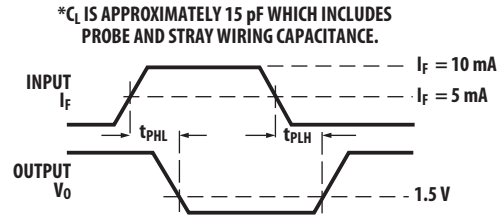

Figure 7. Typical propagation delay vs. temperature.

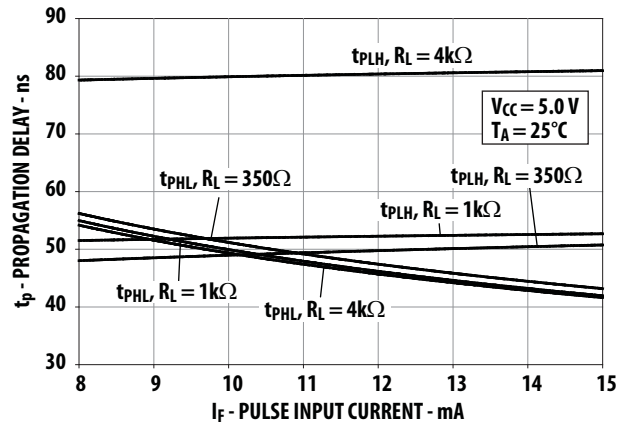

Figure 8. Typical propagation delay vs. pulse input current.

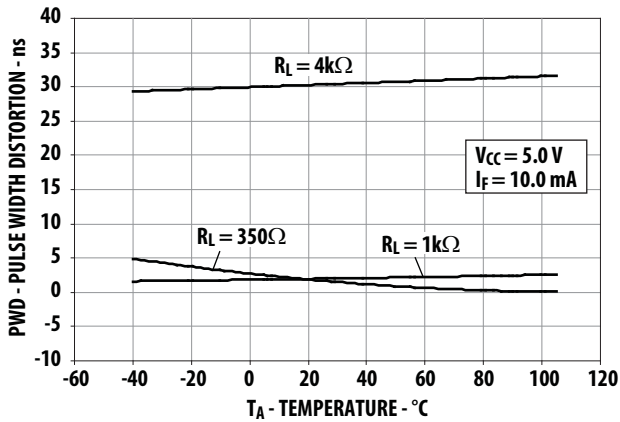

Figure 9. Typical pulse width distortion vs. temperature.

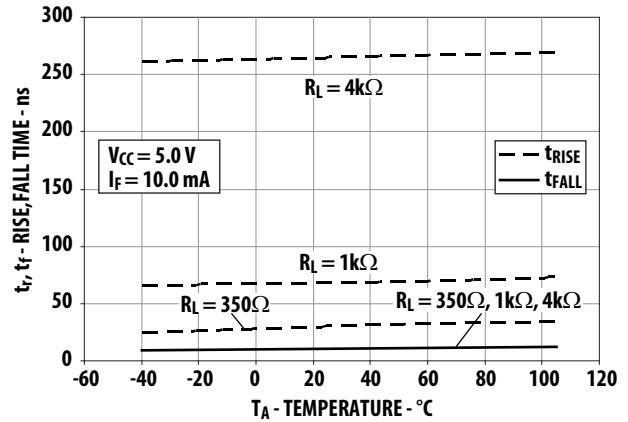
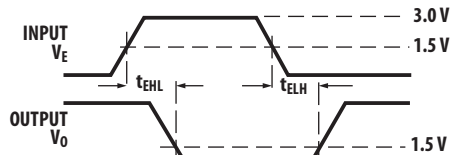
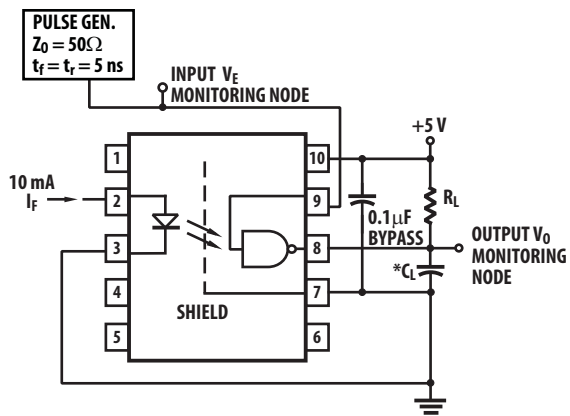

Figure 10. Typical rise and fall time vs. temperature.





\* $C_L$  IS APPROXIMATELY 15 pF WHICH INCLUDES PROBE AND STRAY WIRING CAPACITANCE.

Figure 11. Test circuit for  $t_{EHL}$  and  $t_{ELH}$ .

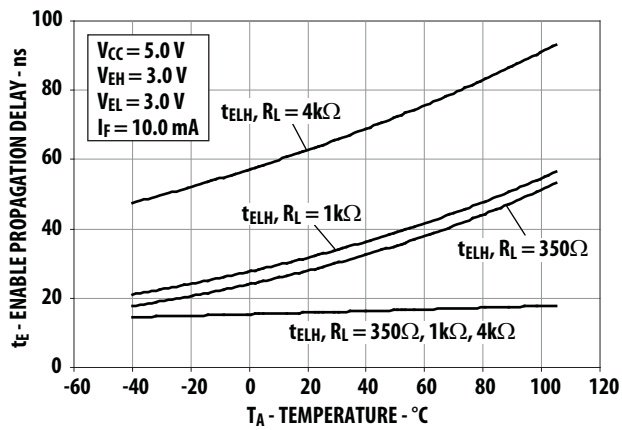

Figure 12. Typical enable propagation delay vs. temperature.

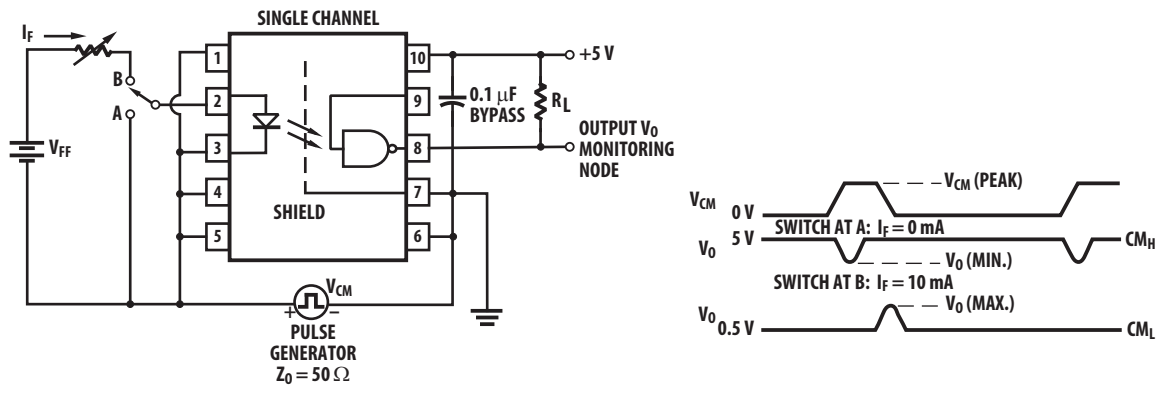

Figure 13. Test circuit for common mode transient immunity and typical waveforms.

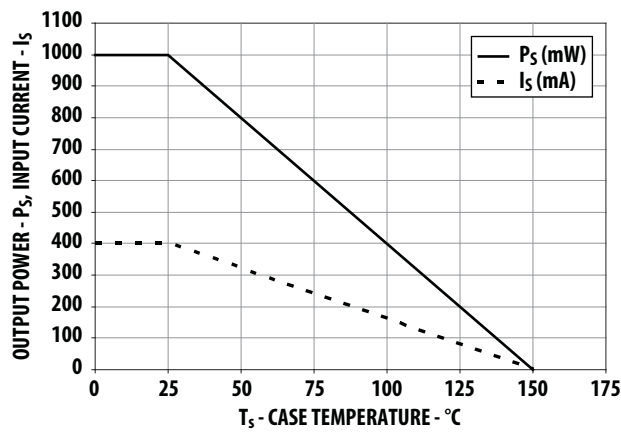

Figure 14. Thermal derating curve, dependence of safety limiting value with case temperature per IEC/EN/DIN EN60747-5-5.

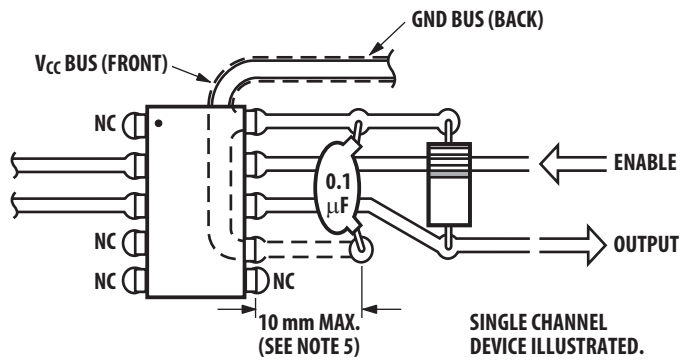

Figure 15. Recommended printed circuit board layout.

For product information and a complete list of distributors, please go to our web site: [www.avagotech.com](http://www.avagotech.com)

Avago, Avago Technologies, and the A logo are trademarks of Avago Technologies in the United States and other countries. Data subject to change. Copyright © 2005-2012 Avago Technologies. All rights reserved. AV02-2457EN - August 15, 2012

