

GENERAL DESCRIPTION

The ACP2766 is a step-up DC-DC converter which operating as current source to drive white LEDs. The light intensity of LEDs is proportional to the current passing through them. The default white LEDs current is set with the external resistor, and the feedback voltage reference is set to 200mV. During the operation, the LED current can be pulsed by adding a PWM signal to the chip, through which the duty cycle changes the feedback reference voltage. With fixed frequency of 1.2MHz, ACP2766 is allowed using tiny inductor and capacitors to minimize the footprint. For maximum protection, the chip features open LED protection function that can disable the chip to prevent the output voltage from exceeding voltage rating during open LED conditions.

FEATURES

- 2.7V to 5.5V Input Voltage Range
- 200mV Reference Feedback Voltage
- 1.2MHz Fixed Frequency
- Internal 38V Open LED Protection
- Integrated 40V, 1.5A MOSFET
- 10~100KHz PWM Dimming Control Range
- Internal Soft Start
- Under-Voltage Protection
- Over Thermal Shutdown
- Low EMI and Improved PSRR
- TSOT26 Package Available

APPLICATION

- 3'~10' TFT WLED Backlight
- GPS,DSC,PAD
- Cell Phone

APPLICATION CIRCUIT

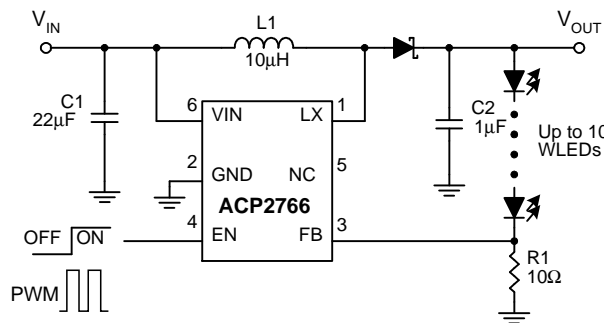

Figure 1. Typical 10 WLEDs Application

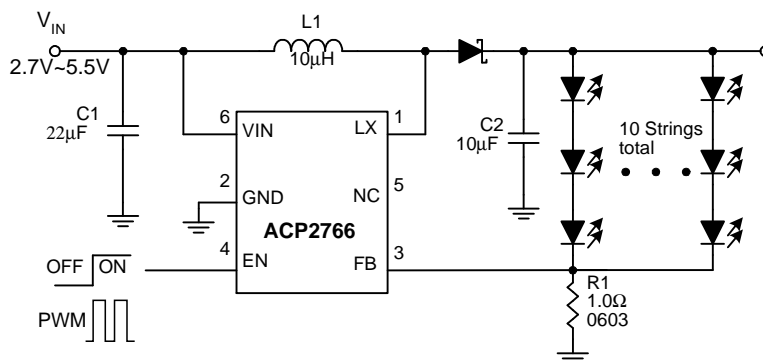
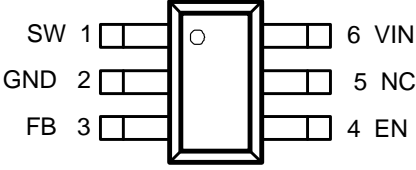

Figure 2. Circuit for driving 30WLEDs

▼ PIN CONFIGURATION

Pin Configuration	Pin Description		
	Pin#	Symbol	Function
	1	SW	Switching Pin.
	2	GND	Ground Pin.
	3	FB	Feedback Pin
	4	EN	Enable and Dimming Control Pin.
	5	NC	No Connection
	6	VIN	Input Supply.

▼ ORDERING INFORMATION

Standard Part NO.	Package	Packing	Min. Quantity
ACP2766EAA	TSOT26	Tape & Reel	3000PCS

▼ ABSOLUTE MAXIMUM RATINGS

Symbol	Parameter	Rating	Unit	
VIN, CTRL, FB	Voltage on VIN, CTRL, FB	-0.3~+6.5	V	
SW	Voltage on SW	-0.3~+40	V	
θ_{JA}	Package Thermal Resistance(TSOT23-6)	190	°C/W	
T _{STG}	Storage Temperature	-65~+150	°C	
T _J	Junction Temperature	-40~+150	°C	
T _{OP}	Recommend Operating Temperature	-40~+85	°C	
MM	ESD	Machine Model	300	V
CDM		Charged-Device Model	1000	V
HBM		Human Body Model	2500	V

▼ ELECTRICAL CHARACTERISTICS

(TA=25°C, Unless Otherwise noted)

Parameter	Symbol	Conditions	Min	Typ	Max	Unit
Operating Voltage	V _{IN}		2.7		6	V
Feedback Voltage	V _{FB}	100% Duty Cycle TA=+25°C	194	200	206	mV
		10% Duty Cycle TA=+25°C	18.5	20.5	22.5	mV
		1% Duty Cycle TA=+25°C	1.65	2.55	3.25	mV
FB Pin Bias Current	I _{FB}		0.001	0.3	μA	
Quiescent Current	I _Q	V _{FB} =0.15V		0.2	0.35	mA
Shutdown Quiescent Current	I _{SHDN}	V _{EN} =0V			1	μA
Switching Frequency	f		0.95	1.20	1.45	MHz
Maximum Duty Cycle	D _{MAX}				100	%
Switch Current Limit	I _{LIMIT}		1.2	1.5	1.8	A
Resistance of Power Switch	R _{DS(ON)}			0.5		Ω
Pin Voltage	V _{EN}	Active high	1.5			V
		Active low			0.4	
Dimming Frequency Range	F _{PWM}		10		100	KHz
Recommend Dimming Range	D _{RCM}		0.25		100	%
Thermal Shutdown Threshold	T _{SHUT}			160		°C
OVP Voltage	V _{OVP}		36	38	40	V
Soft-start Time	T _{SS}		60			nS

PERFORMANCE CHARACTERISTICS

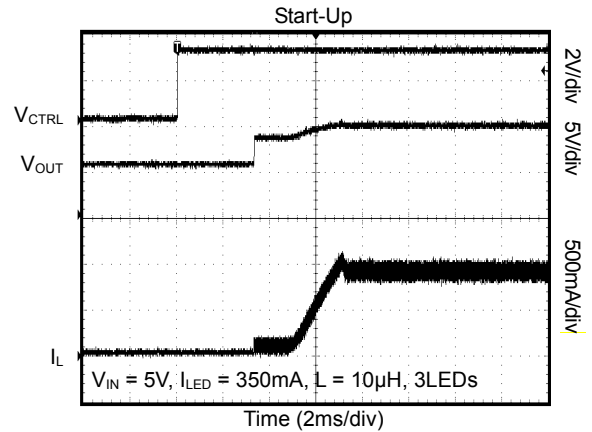
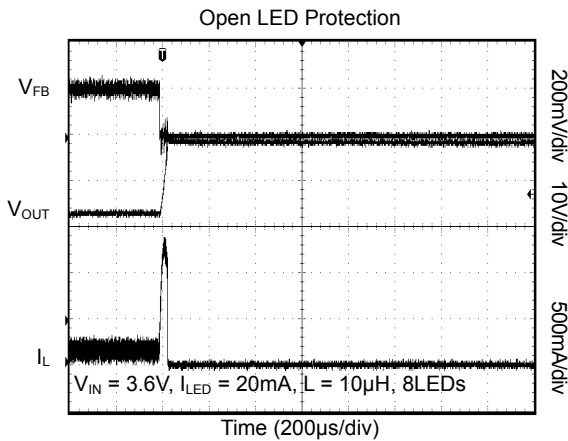
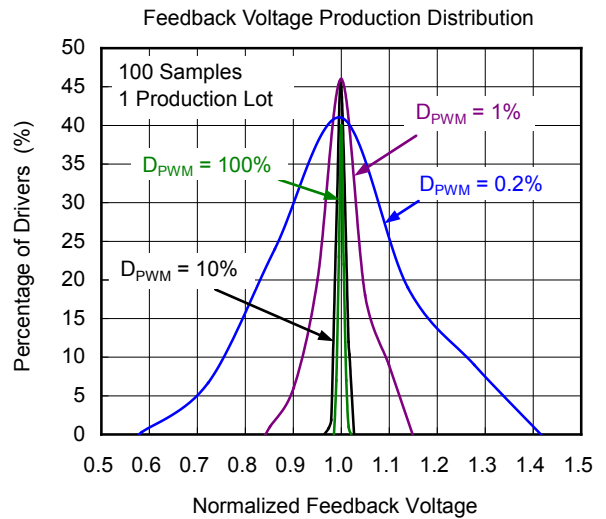
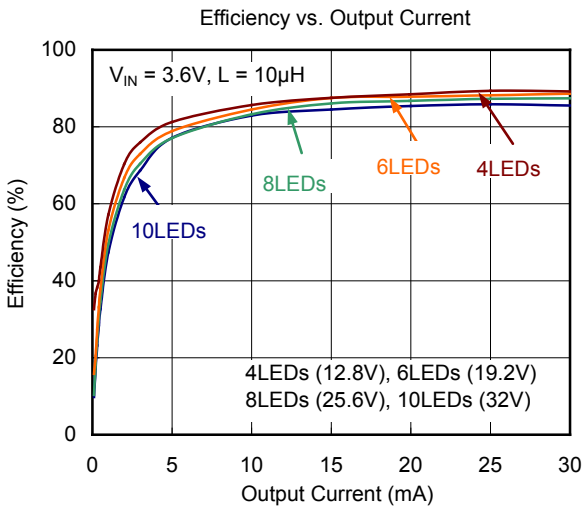
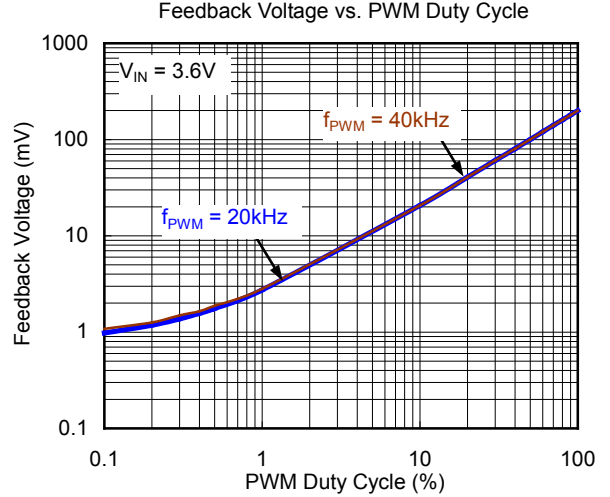
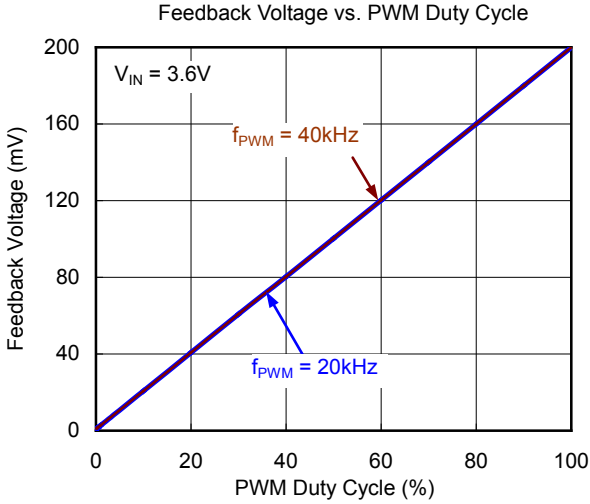

FUNCTION BLOCK

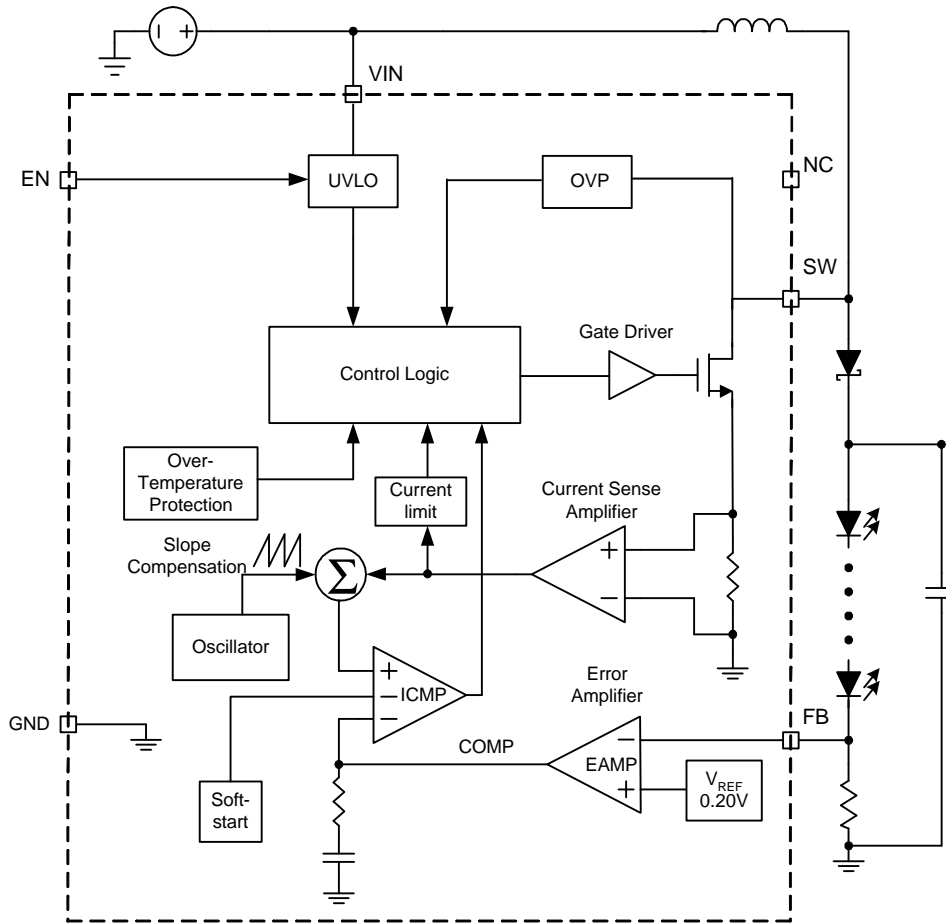

LAYOUT GUIDES

For all switching power supplies, the layout is an important step in the design:

1. The input capacitor should be placed close to the VIN and the GND. Connecting the capacitor with VIN and GND pins by short and wide tracks without using any vias for filtering and minimizing the input voltage ripple.
2. The inductor should be placed as close as possible to the SW pin to minimize length of the copper tracks as well as the noise coupling into other circuits.
3. Since the feedback pin and network is a high impedance circuit, the feedback network should be routed away from the inductor. The feedback pin and feedback network should be shielded with a ground plane or track to minimize noise coupling into this circuit.
4. A star ground connection or ground plane minimizes ground shifts and noise is recommended.

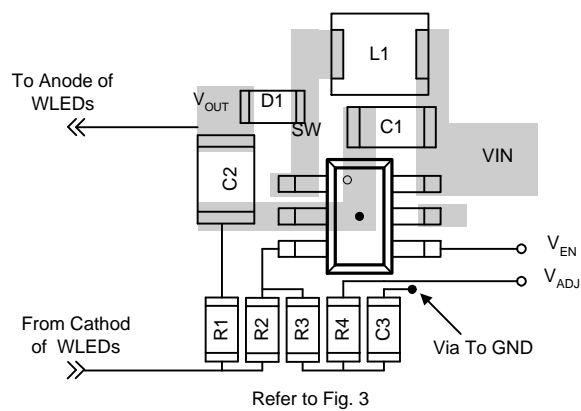

Optimized ACP2766 Layout

PACKAGE INFORMATION

• TSOT26

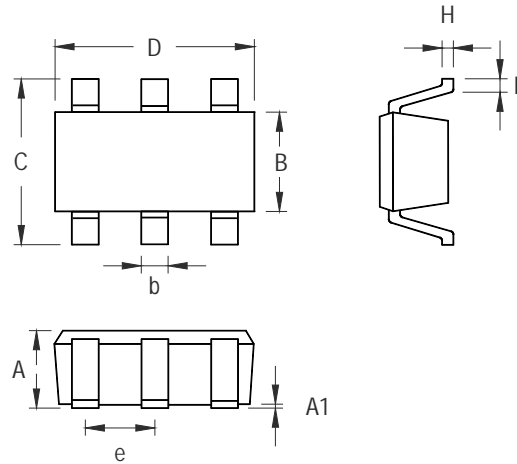

Symbol	Dimensions In Millimeters		Dimensions In Inches	
	Min	Max	Min	Max
A	0.700	1.000	0.028	0.039
A1	0.000	0.100	0.000	0.004
B	1.397	1.803	0.055	0.071
b	0.300	0.559	0.012	0.022
C	2.591	3.000	0.102	0.118
D	2.692	3.099	0.106	0.122
e	0.838	1.041	0.033	0.041
H	0.080	0.254	0.003	0.010
L	0.300	0.610	0.012	0.024