



ACT353 5V 450mA~650mA

Very Low Cost Cell Phone Charger Using ActivePSR™ ACT353

FEATURES

- Patented primary switching regulator technology (No OPTO, secondary CV/CC circuit)
- Lowest total cost solution for cell phone charger using PWM IC
- Universal input voltage range from 90 to 264 VAC
- Accurate CV (5%) and CC (10%) performance
- CV & CC correction for Input line, output DC cord and transformer inductance variation
- No-load standby power < 0.3W
- Exceed CEC average efficiency requirement
- No Y capacitor or CM choke for EMI filter
- Short circuit and over-voltage protection

SPECIFICATION

DESCRIPTION	CONDITION	MIN	TYP	MAX	UNITS
INPUT					
Voltage		90		264	VAC
Frequency		47		63	Hz
No-load Standby Power	85-264VAC, no Load			0.3	W
OUTPUT					
Voltage		4.75	5.0	5.25	V
Current		450	450	650	mA
Power		2.14	2.25	3.41	W
Ripple Voltage				150	mVpp
Average Efficiency	115 or 230 VAC		59.10		%
ENVIRONMENTAL					
Conducted EMI	No Y capacitor	CISPR22/ FCC Part15 Class B			
Safety		EN60950/UL1950			
Surge	Differential mode			2	kV
	Common mode			2	kV
ESD	Contact			8	kV
	Through air			15	kV
Ambient Temperature	Free convection	0		50	°C

1. DEMO BOARD PHOTO

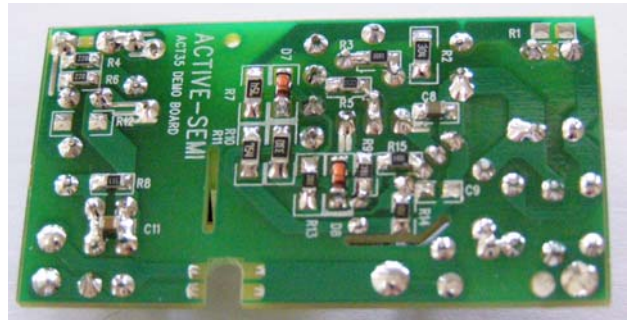
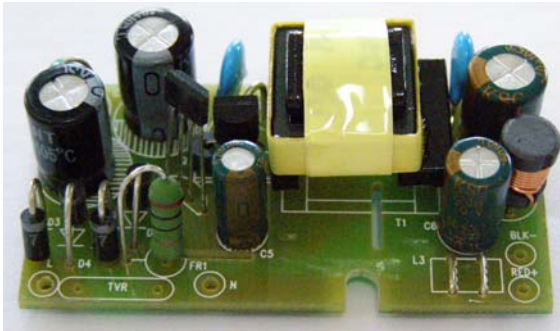

2. SCHEMATICS

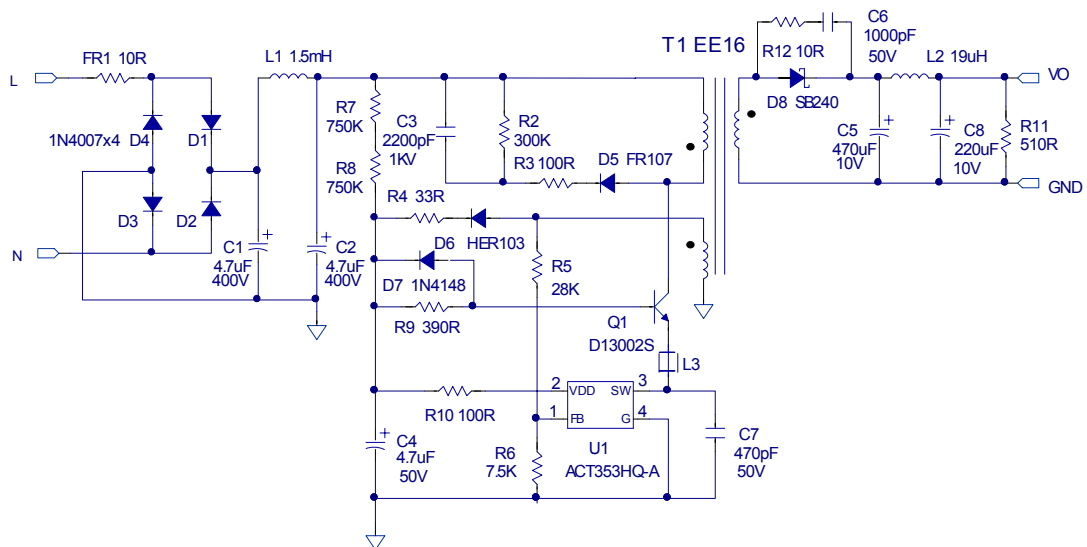

3. PCB LAYOUT

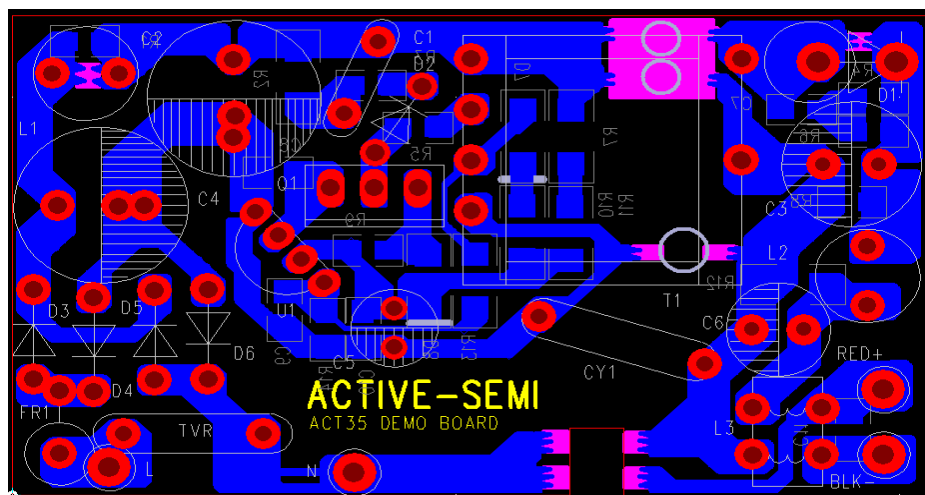

4. BILL OF MATERIALS

Item	Reference	Description	QTY	Manufacturer	Remark
1	C1,2	Capacitor, Electrolytic, 4.7uF/400V, 8x11.5mm	2	KSC	
2	C3	Capacitor, Ceramic, 2200pF/1kV, Dip	1	POE	
3	C4	Capacitor, Electrolytic, 4.7uF/50V, 5x11mm	1	KSC	
4	C5	Capacitor, Electrolytic, 470uF/10V, 6.3x11mm	1	KSC	
5	C6	Capacitor, Ceramic, 1000pF/50V, 0805,SMD	1	POE	
6	C7	Capacitor, Ceramic, 470pF/50V, 0805,SMD	1	POE	
7	C8	Capacitor, Electrolytic, 220uF/10V, 6.3x11mm	1	KSC	
8	D1-D4	Diode, Rectifier,1000V/1A, N4007,DO-41	4	Good-Ark	
9	D5	Diode, Ultra Fast, FR107,1000V/1.0A, DO-41	1	Good-Ark	
10	D6	Diode, Ultra Fast, HER103, 200V/1.0A	1	Good-Ark	
11	D7	Diode,Switching,75V/150mA 1N4148 Milimelf	1	Good-Ark	
12	D8	Diode, schottky, 40V/2A, SB240, DO-15	1	Good-Ark	
13	L1	Axial Inductor, 1.5mH, 0410,Dip	1	Amode Tech	
14	Q1	Transistor, NPN, 600V, 1.5A, D13002S, TO-92	1	Hua Wei	
15	PCB1	PCB, L*W*T=52x30x1.5mm, FR-4	1	TY-OHM	
16	FR1	Fusible Resistor, 1W, 10 ohm, 5%	1	TY-OHM	
17	R2	Meter Film Resistor, 300K ohm, 1206, 5%	1	TY-OHM	
18	R3,10	Meter Film Resistor, 100 ohm, 0805, 5%	2	TY-OHM	
19	R4	Meter Film Resistor, 33 ohm, 0805, 5%	1	TY-OHM	
20	R5	Meter Film Resistor, 28K ohm, 0805,1%	1	TY-OHM	
21	R6	Meter Film Resistor, 7.5K ohm, 0805,1%	1	TY-OHM	
22	R7,8	Meter Film Resistor, 750K ohm, 1206, 5%	2	TY-OHM	
23	R9	Meter Film Resistor, 390 ohm, 0805, 5%	2	TY-OHM	
24	R11	Meter Film Resistor, 510 ohm, 0805, 5%	1		
25	R12	Meter Film Resistor,10 ohm, 1206, 5%	1	TY-OHM	
26	T1	Transformer, Lp=2mH, EE16	1		
27	U1	IC, ACT353HQ-A,SIP-4	1	Active-Semi.	
28	L2	Inductor D6*8mm \varnothing 0.4mm*22T 19uH	1		
29	L3	Bead, ferrite core T3.5*9*1.3mm	1	KC	

5. TRANSFORMER SPECIFICATION

5.1. Schematics

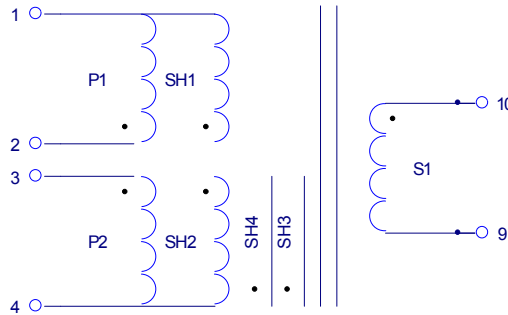

5.2. Build-up Table

Winding	Terminal		Turns	Wire			Insulation	
	Start	Finish		Type	Size*QTY	Layer	Thick/Wide	Layer
SH1	open	1	11	2UEW	0.15Φ*4	1	25u/8.5mm	2
P1	2	1	130	2UEW	0.15Φ*1	3	25u/8.5mm	2
SH2	open	4	11	2UEW	0.15Φ*4	1	25u/8.5mm	2
S1	10	9	10	TEX-E	0.5Φ*1	1	25u/8.5mm	2
SH3	4	open	0.9	7mm Copper	0.025*7mm	1	25u/8.5mm	2
P2	3	4	32	2UEW	0.2Φ*1	1	25u/8.5mm	2
SH4	4	open	0.9	7mm Copper	0.025*7mm	1	25u/8.5mm	3

Note: SH1 & SH2 are shielding, SH3 & SH4 copper covered with tape on both edges ;
P1 & P2 are primary and S1 is secondary

5.3. Build-up Diagram

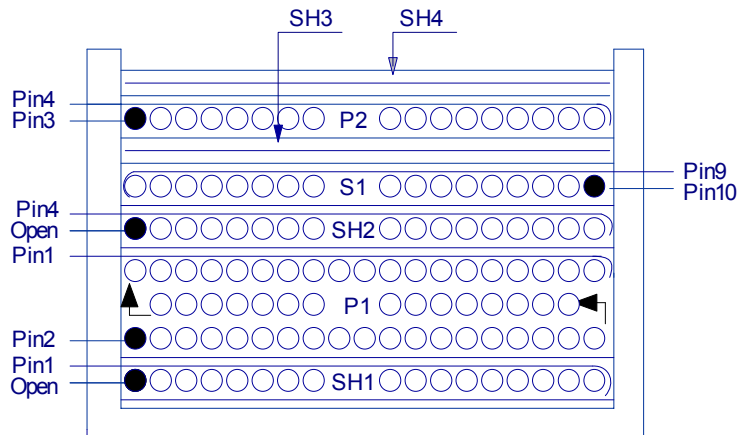

5.4. Electrical Specifications

Item	Description	Condition	Limits
1	Electrical Strength	50Hz, 1 minute, from primary and secondary	3000 Vac
2	P1 Inductance	Inductance between pins 1 and 2 at 1Vac & 1kHz	2mH ± 7%
3	P1 Leakage Inductance	Inductance between pins 1 and 2 with pins 3-4 and 9-10 shorted	75μH

6. FUNCTIONAL TEST

6.1. Standby Power

Condition	85 V _{AC} (W)	110 V _{AC} (W)	220V _{AC} (W)	264 V _{AC} (W)	Green Mode Limit (W)	Pass/Fail
0% P _o =0W	0.12	0.13	0.17	0.21	0.3	Pass

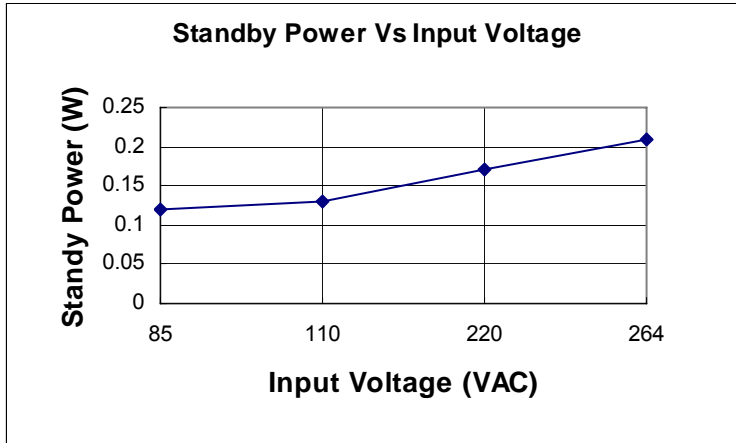

6.2. Efficiency

V _{IN} (VAC)	25% P _o (0.625W)	50% P _o (1.25W)	75% P _o (1.875W)	100% P _o (2.5W)	Average Eff(%)	CEC Limit (%)	Pass/Fail
110	58.496%	64.745%	68.100%	69.003%	65.09%	58.25%	Pass
220	51.670%	60.975%	67.021%	69.505%	62.293%	58.25%	Pass

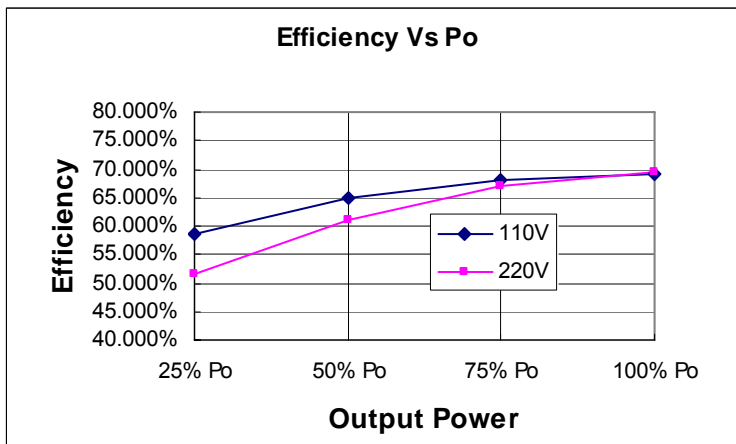

6.3. Line and Load Regulation

V _{IN} (V _{AC})	0% P _o (0W)	25% P _o (0.625W)	50% P _o (1.25W)	75% P _o (1.875W)	100% P _o (2.5W)	Voltage Limit (V)	Pass/Fail
85	4.927	5.038	5.050	5.066	5.093	4.75-5.25	Pass
110	4.932	5.042	5.045	5.062	5.077	4.75-5.25	Pass
220	4.935	5.102	5.036	5.055	5.072	4.75-5.25	Pass
264	4.926	5.022	5.045	5.050	5.065	4.75-5.25	Pass

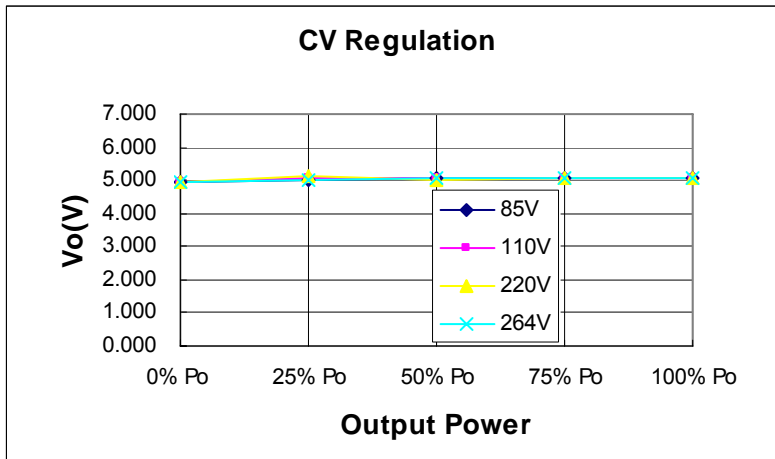

6.4. Ripple and Noise

V _{IN} (V _{AC})	0% P _o (0W)	50% P _o (1.25W)	100% P _o (2.5W)	Ripple Limit (mV)	Pass/Fail
85	44	112	129	150	Pass
110	34	104	140	150	Pass
220	54	114	138	150	Pass
264	32	146	138	150	Pass

6.5. Turn-on and Turn-off

		Turn-on		Turn-off	
		Delay (mS)	Overshoot (mV)	Delay (mS)	Overshoot (mV)
85V, P _o (W)	0	1460	320	398	800
	2.5	1320	0	11.2	0
264V, P _o (W)	0	258	400	4020	800
	2.5	450	0	168	0

6.6. Current Limit and Constant Current

Condition	85 V _{AC} (mA)	110 V _{AC} (mA)	220V _{AC} (mA)	264 V _{AC} (mA)	Current Limit (mA)	Pass/Fail
95% V _o	548	538	555	551	450-650	Pass
90% V _o	548	542	554	549	450-650	Pass
80% V _o	556	549	564	562	450-650	Pass
70% V _o	566	555	569	570	450-650	Pass
60% V _o	573	558	571	571	450-650	Pass
50% V _o	569	556	573	569	450-650	Pass
40% V _o	564	558	571	560	450-650	Pass
38% V _o	562	553	568	558	450-650	Pass
36% V _o	561	551	566	555	450-650	Pass

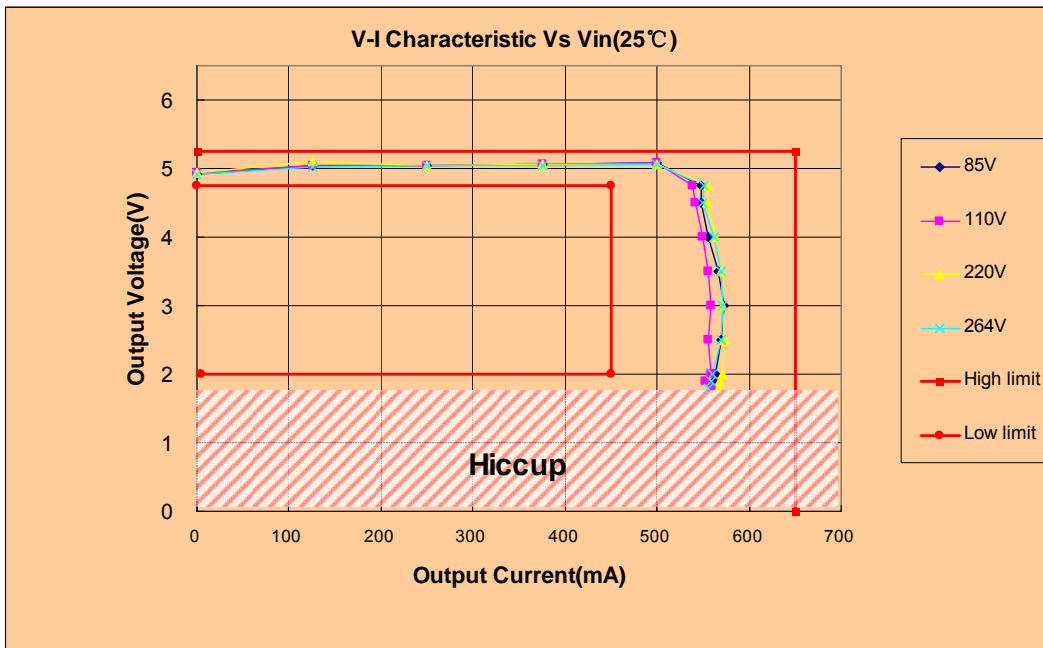

6.7. Short Circuit Protection and Release

Protection	85 VAC	110 VAC	220VAC	264 VAC
Pin (W)	0.16	0.18	0.3	0.38

Release	Delay (mS)	Overshoot (mV)
85 VAC, 0% Po=0W	8	320
85 VAC, 100% Po=2.5W	60	0
264 VAC, 0% Po=0W	6	320
264 VAC, 100% Po=2.5W	60	240

6.8. Dynamic Load

Condition	Undershoot(mV)	Overshoot(mV)
110VAC, 0%-100% load	480	360
110VAC, 50%-100% load	220	240
220VAC, 0%-100% load	420	380
220VAC, 50% -100% Load	200	180

6.9. Brown-out Test

Condition	Pin (W)	Vo (V)
85 VAC, 100% Po=2.5W	3.83	5.102
80 VAC, 100% Po=2.5W	3.88	5.093
75 VAC, 100% Po=2.5W	3.93	5.082
70 VAC, 100% Po=2.5W	3.96	5.059
65 VAC, 100% Po=2.5W	4.05	5.051
60 VAC, 100% Po=2.5W	4.041	4.926
55 VAC, 100% Po=2.5W	Hiccup	Hiccup
45 VAC, 100% Po=2.5W	Hiccup	Hiccup

7. EMC TEST

7.1. Conducted EMI

Condition	Configuration	Margin(dB)	Pass/Fail
220 VAC, 100% Po=2.25W	Line – QP	<-6	Pass
220 VAC, 100% Po=2.25W	Line - Average	<-6	Pass
220 VAC, 100% Po=2.25W	Neutral - QP	<-6	Pass
220 VAC, 100% Po=2.25W	Neutral - Average	<-6	Pass

EMI TEST REPORT

Organization: ACTIVE-SEMI	Operator: Lisa TAN	EUT: ACT353	parameter
Place: ACTIVE-SEMI	Time: 2007/9/22/14:31		
Detector: PK+AV	Test-time(ms): 30		
Limit: GB9254	Transductor: 10		
Remark: ACT353 14# 5V 450mA L			

Start(MHz)	End(MHz)	Step(MHz)	freq, step
0.150	2.000	0.009	
2.000	10.000	0.015	
10.000	30.000	0.025	

dBuV scan result

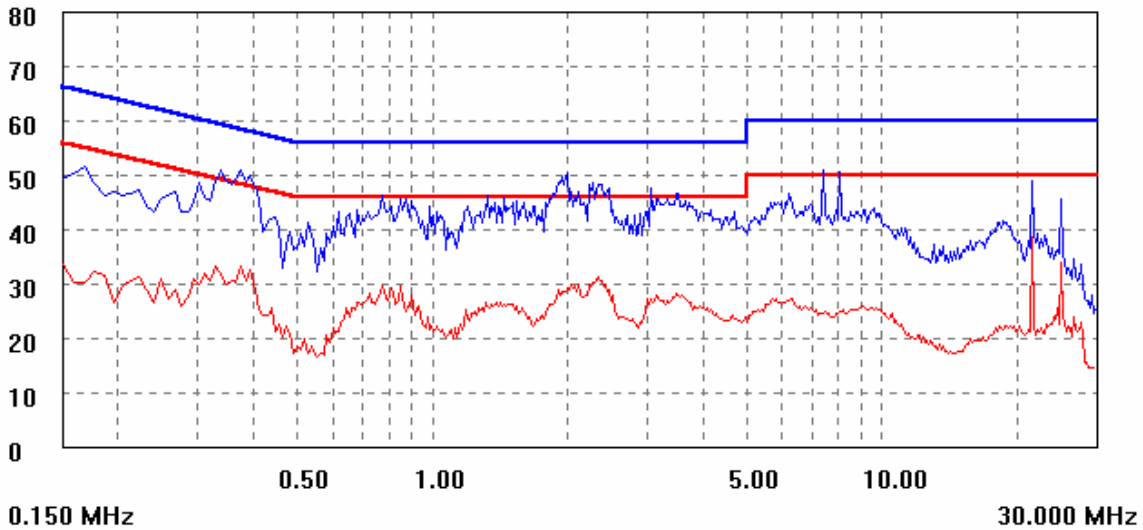

EMI TEST REPORT

Organization: ACTIVE-SEMI	Operator: Lisa TAN	EUT: ACT353	parameter
Place: ACTIVE-SEMI	Time: 2007/9/22/14:35		
Detector: PK+AV	Test-time(ms): 30		
Limit: GB9254	Transductor: 10		
Remark: ACT353 14# 5V 450mA N			

Start(MHz)	End(MHz)	Step(MHz)	freq, step
0.150	2.000	0.009	
2.000	10.000	0.015	
10.000	30.000	0.025	

dBuV scan result

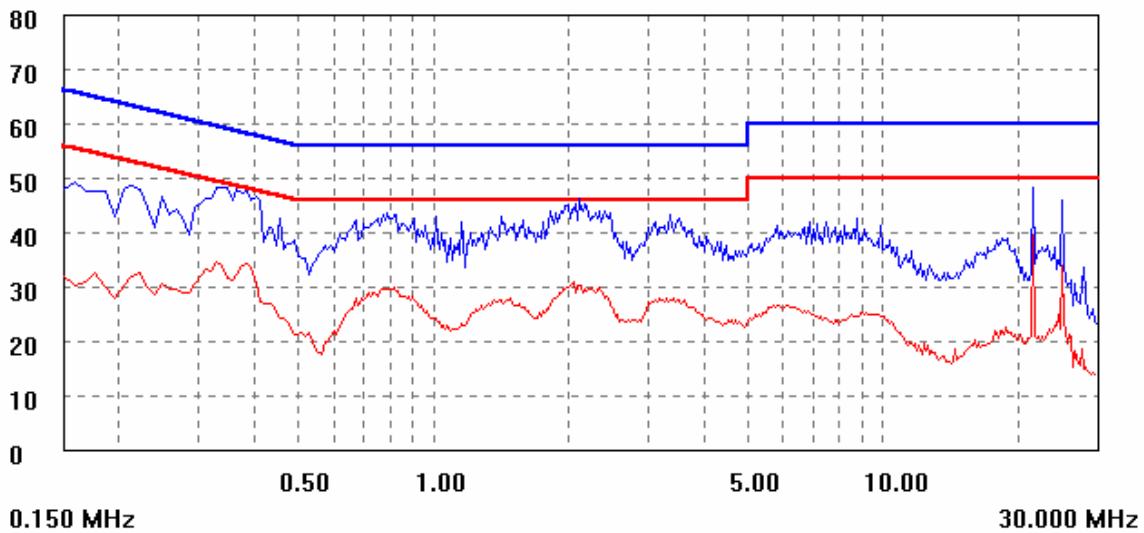

7.2. Radiated EMI

Condition	Configuration	Margin(dB)	Pass/Fail	Test Limit
220 VAC, 100% Po=2.5W	Vertical	< -6dB	Pass	-6dB Margin
220 VAC, 100% Po=2.5W	Neutral - Average	< -6dB	Pass	-6dB Margin



Audix Technology (Shanghai) Co., Ltd.
 3F #34Bldg. No.680 GuiPing Rd.,
 CaoHeJing Hi-Tech Park,
 Shanghai, China 200233
 Tel: +86-21-64955500 Fax: +86-21-64955491
 audixaci@audix.com

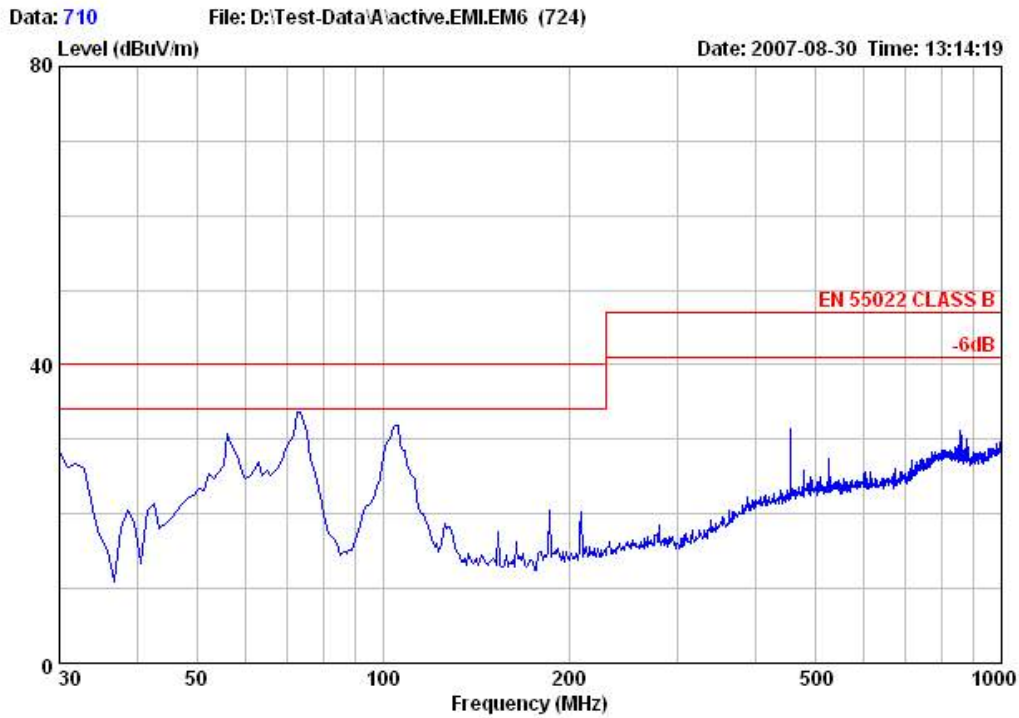

Site : Chamber 3
 Condition : EN 55022 CLASS B 3m VERTICAL RBW:120KHz VBW:300KHz SWT:0.05sec
 Project No. :
 Applicant :
 EUT : Adapter
 M/N : ACT353
 S/N : EE16 5V 0.5A
 Power Supply : 230V/50Hz
 Ambient : 22°C 60%RH
 Test Mode :
 Test Engineer : Leo
 Memo :



Audix Technology (Shanghai) Co., Ltd.
 3F #34Bldg. No.680 GuiPing Rd.,
 CaoHeJing Hi-Tech Park,
 Shanghai, China 200233
 Tel: +86-21-64955500 Fax: +86-21-64955491
 audixaci@audix.com

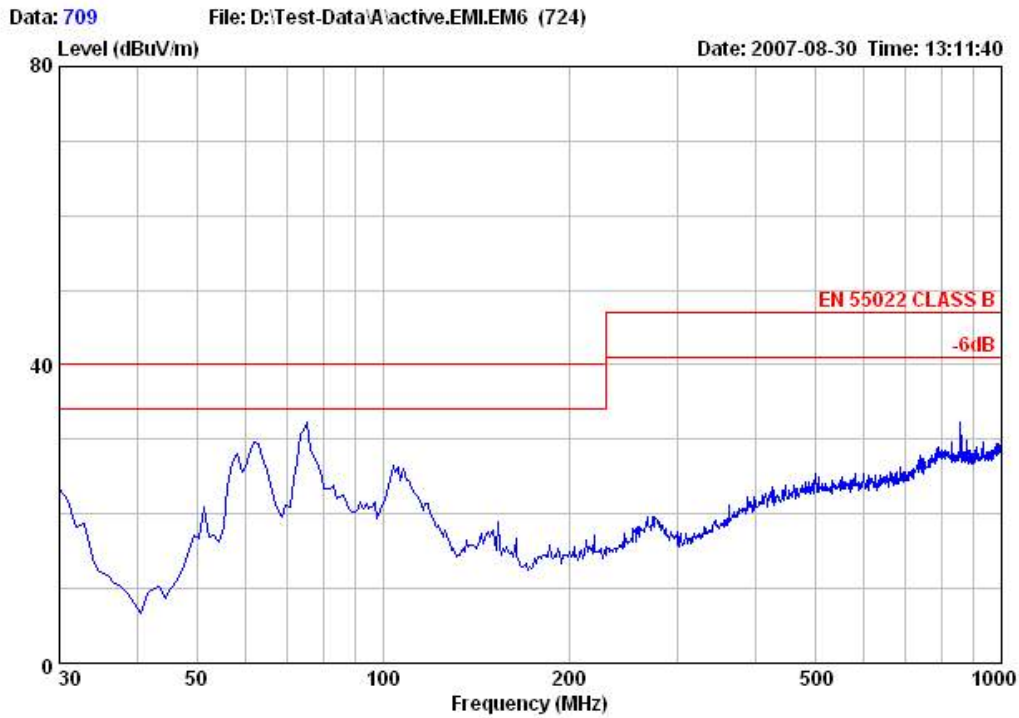

Site : Chamber 3
 Condition : EN 55022 CLASS B 3m HORIZONTAL RBW:120KHz VBW:300KHz SWT:0.05sec
 Project No. :
 Applicant :
 EUT : Adapter
 M/N : ACT353
 S/N : EE16 5V 0.5A
 Power Supply : 230V/50Hz
 Ambient : 22°C 60%RH
 Test Mode :
 Test Engineer : Leo
 Memo :

7.3. Surge

Condition	Configuration	Pass/Fail	Test Limit
220 VAC, 100% Po=2.5W	Line – Neutral	Pass	2kV

7.4. ESD

Condition	Method	Test Limit	Pass/Fail
220 VAC, 100% Po=2.5W	Air Discharge	8kV	Pass
220 VAC, 100% Po=2.5W	Contact Discharge	15kV	Pass

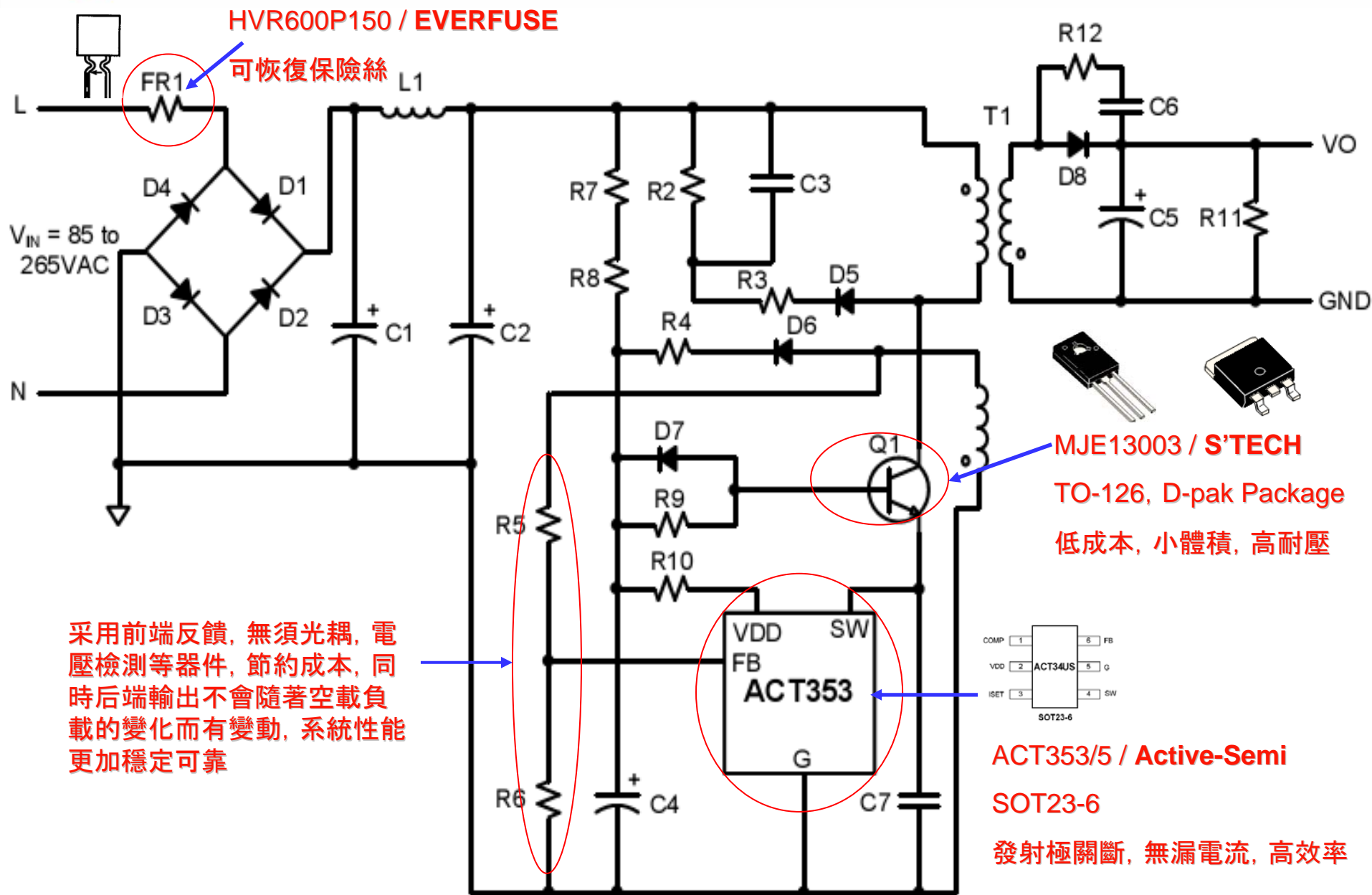

采用前端反饋, 無須光耦, 電壓檢測等器件, 節約成本, 同時后端輸出不會隨著空載負載的變化而有變動, 系統性能更加穩定可靠

ACT353/5 / Active-Semi
SOT23-6

發射極關斷, 無漏電流, 高效率