

## Standard Products

# ACT4454/4460 Single Supply Dual Transceivers for MIL-STD-1553A/B & MacAir A3818, A4905, A5232, A5690 & SAE-AS15531

www.aeroflex.com/Avionics

November 10, 2004



## FEATURES

- Small size, light weight and low standby power dual transceivers
- Single +5V power supply
- Monolithic construction
- Input and output TTL compatible design
- Designed for commercial, industrial and aerospace applications
- Processed and screened to MIL-STD-883 specs
- MIL-PRF-38534 compliant devices available
- Aeroflex-Plainview is a Class H & K MIL-PRF-38534 manufacturer
- DESC SMD# 5962-92061



**ACT4454**

**Case Style**

**Actual Size**

## GENERAL DESCRIPTION

The Aeroflex-Plainview ACT4454/4460 series are next generation monolithic transceiver designs which provides full compliance with MIL-STD-1553A/B, MacAir A3818, A5690, A5232, A4905 and meets SAE-AS15531 requirements in the smallest packages with low power consumption and single power supply operation. The series performs the front-end analog function of inputting and outputting data through a transformer to the MIL-STD-1553 data bus.

The ACT4454/4460 series can be considered a "Universal" Transceiver in that it is compatible with MIL-STD-1553A & B, Macair A-3818, A-4905, A-5232, A-5690, A-5690, and meets SAE-AS15531.

Design of these transceivers reflects particular attention to active filter performance. This results in low bit and word error rate with superior waveform purity and minimal zero crossover distortion. Efficient transmitter electrical and thermal design provides low internal power dissipation and heat rise at high as well as low duty cycles.

Each channel of the dual transceiver is completely separate from the other and fully independent. This includes power leads as well as signal lines. Hence, each channel may be connected to a different data bus with no interaction.

## TRANSMITTER

The Transmitter section accepts bi-phase TTL data at the input and when coupled to the data bus with a 1:2.5 ratio transformer the data bus signal is typically 7.0 volts P-P at A-A' (See Figure 5). When both DATA and  $\overline{\text{DATA}}$  inputs are held low or high, the transmitter output becomes a high impedance and is "removed" from the line. In addition, an overriding "INHIBIT" input provides for the removal of the transmitter output from the line. A logic "1" applied to the "INHIBIT" takes priority over the condition of the data inputs and disables the transmitter (See Figure 1 Transmitter Logic Waveform). The Transmitter may be safely operated for an indefinite period with the bus (point A-A') short circuited at 100% duty cycle.

## RECEIVER

The Receiver section accepts bi-phase differential data at the input and produces two TTL signals at the output. The outputs are DATA and  $\overline{\text{DATA}}$ , and represent positive and negative excursions of the input beyond a pre-determined threshold (See Figure 2 Receiver Logic Waveform).

The pre-set internal thresholds will detect data bus signals exceeding 1.20 Volts P-P and reject signals less than 0.6 volts P-P when used with a transformer (See Figure 5 for transformer data and typical connections).

A low level at the Strobe input inhibits the DATA and  $\overline{\text{DATA}}$  outputs. If unused, a 2K pull-up to +5 Volts is recommended.

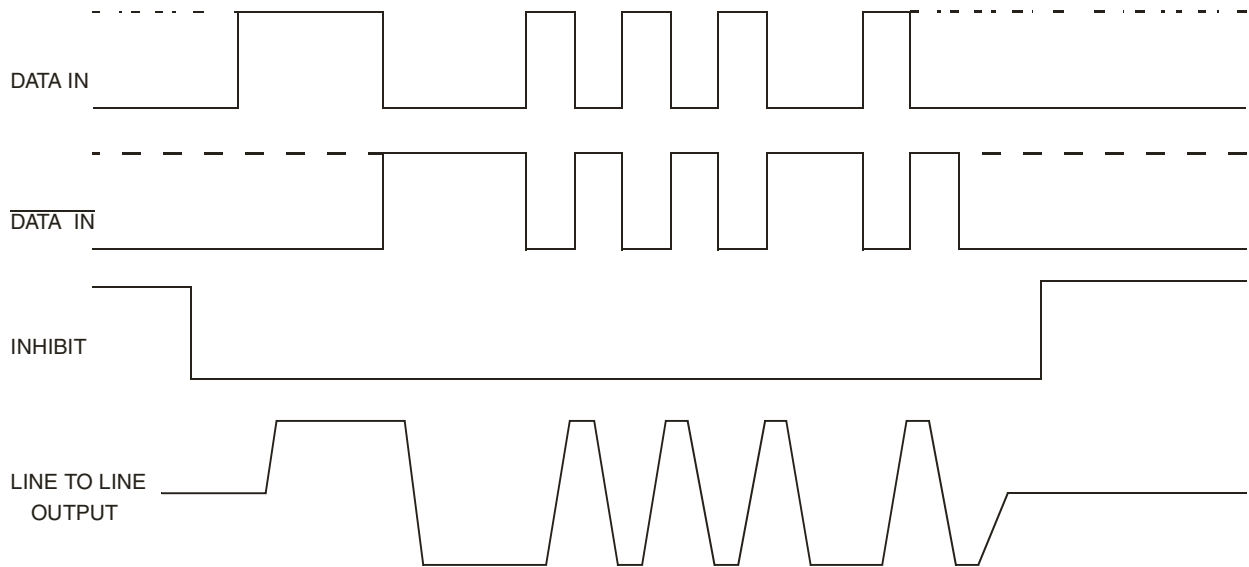
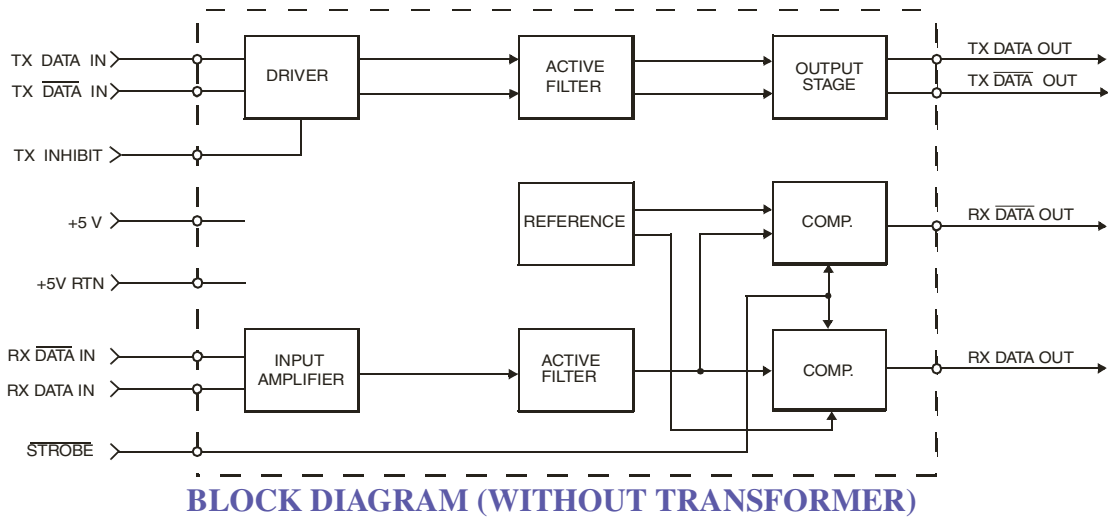

**Note:** DATA and  $\overline{\text{DATA}}$  inputs must be complementary waveforms or 50% duty cycle average, with no delays between them, and must be in the same state during off times (both high or low).

**FIGURE 1 – TRANSMITTER LOGIC WAVEFORMS IDEALIZED \***

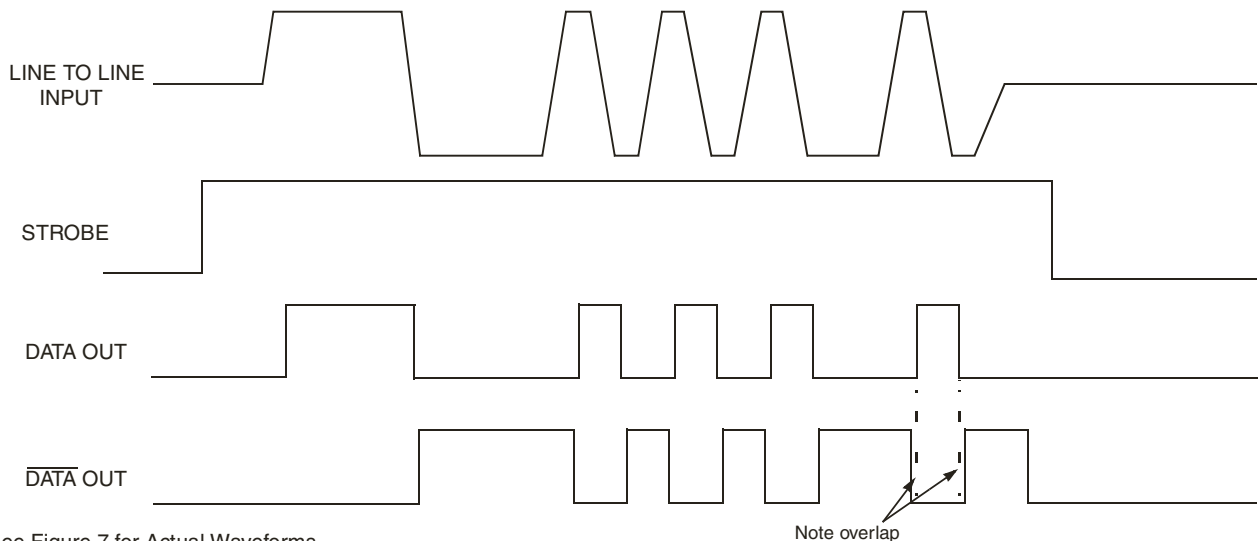

\* See Figure 7 for Actual Waveforms

**FIGURE 2 – RECEIVER LOGIC WAVEFORMS IDEALIZED \***

## ABSOLUTE MAXIMUM RATINGS

Operating case temperature	-55°C to +125°C
Storage case temperature	-65°C to +150°C
Power supply voltage	-0.3V <sub>DC</sub> to +7.0V <sub>DC</sub>
Logic input voltage	-0.3V <sub>DC</sub> to +5.5V <sub>DC</sub>
Receiver differential input	±10 V
Receiver input voltage (common mode)	±5V
Driver peak output current	800 mA
Total package power dissipation over the full operating case temperature range	2.0 Watts (Note: Normal operation conditions require one transmitter on and the other off at any given time)
Maximum junction to case temperature	10°C
Thermal resistance – Junction to case	5°C/W

## ELECTRICAL CHARACTERISTICS – DRIVER SECTION

### INPUT CHARACTERISTICS, TX DATA IN OR TX DATA IN (Notes 2 & 3 Apply)

Parameter	Condition	Symbol	Min	Typ	Max	Unit
"0" Input Current	V <sub>IN</sub> = 0.4V	I <sub>ILD</sub>	-	-0.2	-0.4	mA
"1" Input Current	V <sub>IN</sub> = 2.7V	I <sub>IHD</sub>	-	1	40	μA
"0" Input Voltage		V <sub>ILD</sub>	-	-	0.7	V
"1" Input Voltage		V <sub>IHD</sub>	2.0	-	-	V

### INHIBIT CHARACTERISTICS

"0" Input Current	V <sub>IN</sub> = 0.4V	I <sub>ILI</sub>	-	-0.2	-0.4	mA
"1" Input Current	V <sub>IN</sub> = 2.7V	I <sub>IHI</sub>	-	1.0	40	μA
"0" Input Voltage		V <sub>ILI</sub>	-	-	0.7	V
"1" Input Voltage		V <sub>IHI</sub>	2	-	-	V
Delay from TX inhibit, (0→1) to inhibited output		t <sub>DXOFF</sub>	-	250	450	nS
Delay from TX inhibit, (1→0) to active output		t <sub>DXON</sub>	-	150	450	nS
Differential Output Noise, inhibit mode		V <sub>NOI</sub>	-	2	10	mVp-p
Differential Output Impedance (inhibited)	Note 1	Z <sub>OI</sub>	2K	-	-	Ω

### OUTPUT CHARACTERISTICS

Differential output level	R <sub>L</sub> = 35 Ω	V <sub>O</sub>	6.3	7.0	7.7	V <sub>p-p</sub>
Rise and fall times (10% to 90% of p-p output)		t <sub>r</sub>	200	240	300	nS
Output offset at point A-A' on Figure 5, 2.5 μS after midpoint crossing of the parity bit of the last word of a 600μS message	R <sub>L</sub> = 35 Ω	V <sub>OS</sub>	-	-	±90	mV <sub>peak</sub>
Delay from 50% point of TX DATA or $\overline{\text{TX DATA}}$ input to zero crossing of differential signal		t <sub>DTX</sub>	-	290	400	nS

## ELECTRICAL CHARACTERISTICS – RECEIVER SECTION

Parameter	Condition	Symbol	Min	Typ	Max	Unit
Differential Voltage Range (See Figure 5, point P-P')	TXFMR 2.5:1	$V_{IDR}$	-	14	20	V <sub>p-p</sub>
Common Mode Rejection Ratio (Note 3)		CMRR	45	-	-	dB

### STROBE CHARACTERISTICS (LOGIC "0" INHIBITS OUTPUT)

"0" Input Current	$V_S = 0.4V$	$I_{IL}$	-	-0.2	-0.4	mA
"1" Input Current	$V_S = 2.7V$	$I_{IH}$	-	1	+40	μA
"0" Input Voltage		$V_{IL}$	-	-	0.7	V
"1" Input Voltage		$V_{IH}$	2.0	-	-	V
Strobe Delay (Turn-on or Turn-off)		$t_{SD}$	-	50	100	nS

### THRESHOLD CHARACTERISTICS (SINEWAVE INPUT)

Internal Threshold Voltage (Referred to the bus)	100KHz-1MHz	$V_{TH}$	0.60	0.82	1.10	V <sub>p-p</sub>
--	-------------	----------	------	------	------	------------------

### OUTPUT CHARACTERISTICS, RX DATA AND $\overline{RX DATA}$

"1" State	$I_{OH} = -0.4mA$	$V_{OH}$	2.5	3.7	-	V
"0" State	$I_{OL} = -4mA$	$V_{OL}$	-	0.35	0.5	V
Delay, (average) from differential input zero crossings to RX DATA and $\overline{RX DATA}$ output	50% points	$t_{DRX}$	-	340	500	nS

## POWER DATA

### POWER SUPPLY CURRENTS – PER CHANNEL

Transmitter Standby	Note 4	$I_{CC}$	-	13	30	mA
25% Duty Cycle			-	170	195	
50% Duty Cycle			-	320	345	
100% Duty Cycle			-	700	750	

### POWER SUPPLY VOLTAGE

Operating Power Supply Voltage Range		$V_{CC}$	+4.75	+5.00	+5.50	V
--------------------------------------	--	----------	-------	-------	-------	---

#### NOTES:

- Power on or off, measured from 75KHz to 1MHz at point A-A' and transformer self impedance of 3KΩ minimum.
- $V_{CC} = 5$  Volts  $\pm 0.1$  V, bypassed by 2.2 μF (Tantalum recommended) Capacitor minimum. All measurements & specifications apply over the temperature range of -55°C to +125°C (case temperature) unless otherwise specified.
- When measured at point A-A' with  $\pm 10$  Volt peak, line to ground, DC to 2MHz.
- Typical power is measured with  $V_{bus}$  at point A-A' = 7.0 V<sub>p-p</sub>.

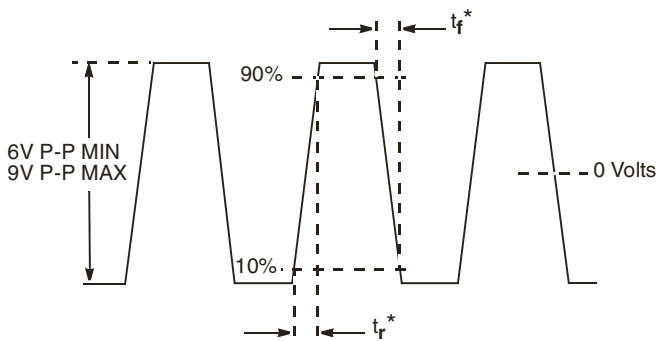

\* Rise and fall times measured at point A-A' in Figure 5

**FIGURE 3 – TRANSMITTER (TX) OUTPUT WAVEFORM**

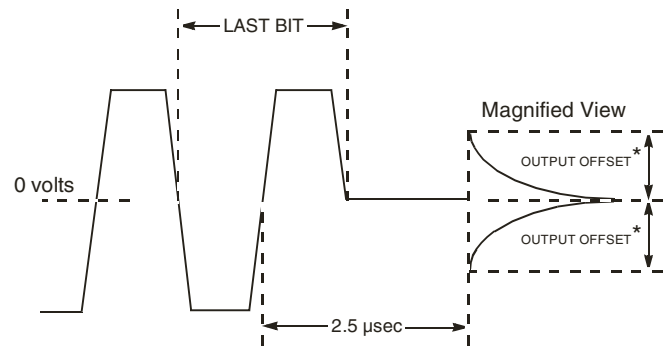

\*Offset measured at point A-A' in Figure 5

**FIGURE 4 – TRANSMITTER (TX) OUTPUT OFFSET**

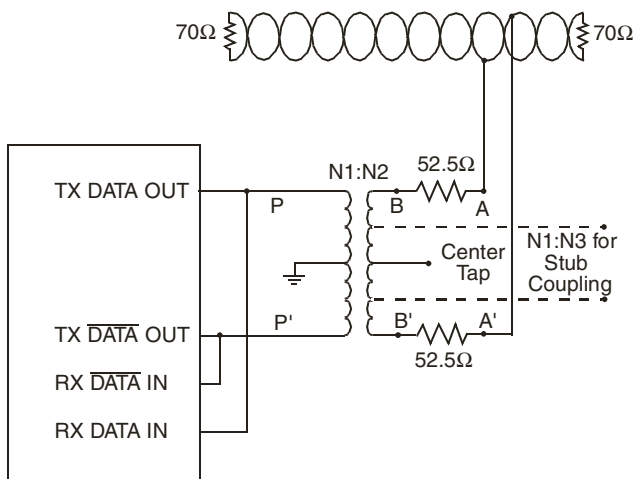

Transformer turns ratios:  
 $N1:N2 = 1:2.5$   
 $N1:N3 = 1:1.77$   
 Use Technitrol 1553-45 or equivalent

**FIGURE 5 – TYPICAL TRANSFORMER DIRECT CONNECTION**

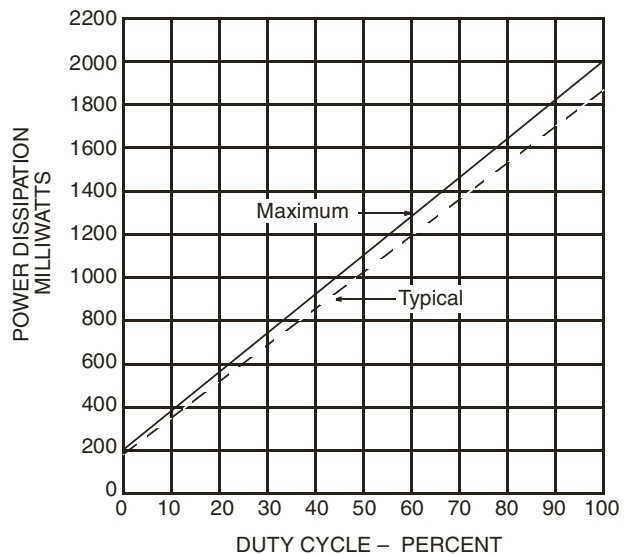

Note:  $V_{CC}=5$  Volts, Transformer ratio 1:2.5,  $V_{BUS}$  (pt A-A') at 7.0 Volts P-P

**FIGURE 6 – POWER DISSIPATION VS. DUTY CYCLE**  
 (Total, hybrid with one channel transmitting and the other not powered)

**START OF WORD – 33 WORD TRANSMISSION**

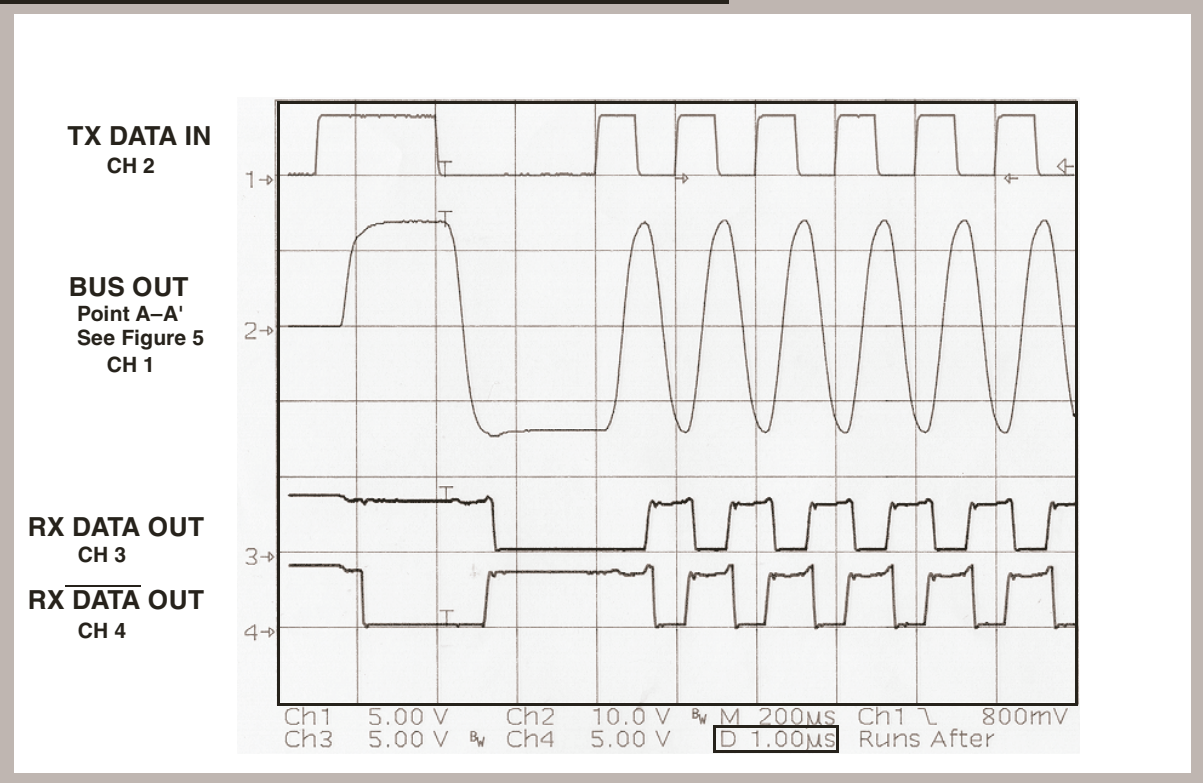

**END OF WORD – 33 WORD TRANSMISSION**

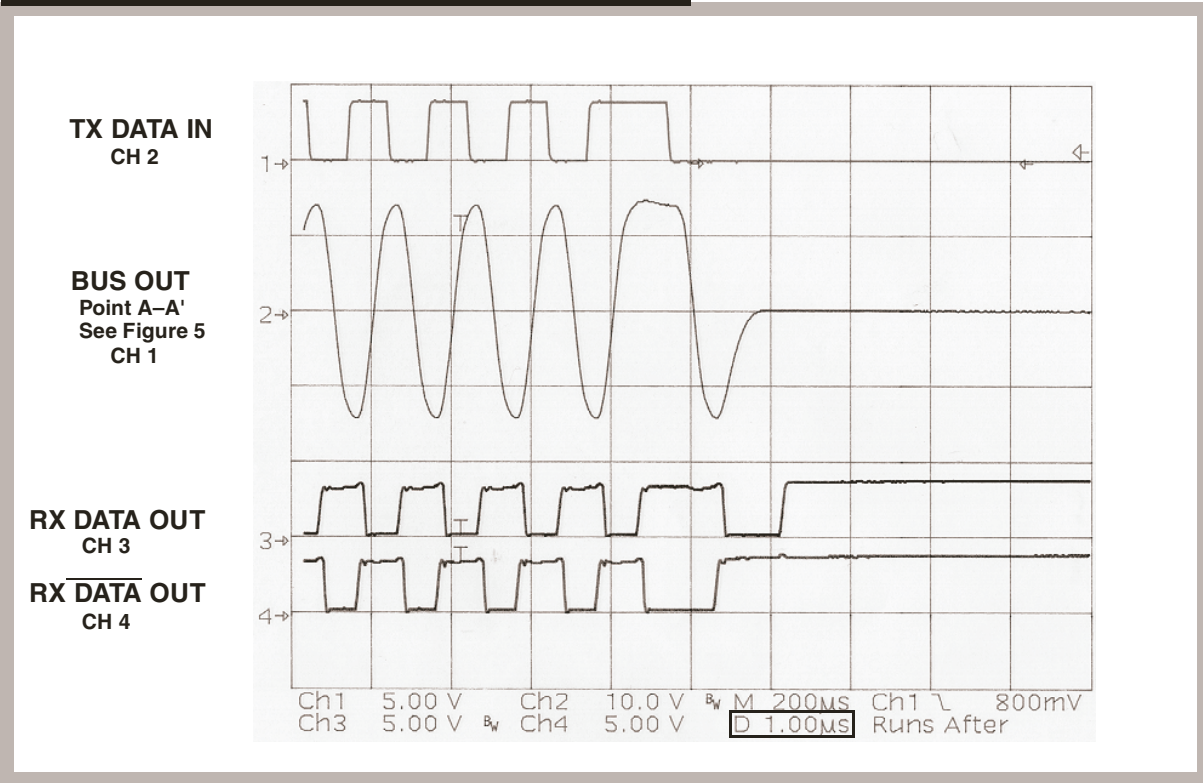

\* Oscilloscope used is a TEK TDS540 with Probe 6139A.

**FIGURE 7 ACTUAL HYBRID WAVEFORMS \* – 25°C TYPICAL**

## PIN NUMBERS & FUNCTIONS

Pin #	Function	Channel
1	TX DATA OUT/RX DATA IN	A
2	TX $\overline{\text{DATA}}$ OUT/RX $\overline{\text{DATA}}$ IN	A
3	GROUND 1	A
4	RX DATA OUT	A
5	STROBE	A
6	RX $\overline{\text{DATA}}$ OUT	A
7	TX DATA OUT/RX DATA IN	B
8	TX $\overline{\text{DATA}}$ OUT/RX $\overline{\text{DATA}}$ IN	B
9	GROUND 1	B
10	RX DATA OUT	B
11	STROBE	B
12	RX $\overline{\text{DATA}}$ OUT	B
13	GROUND 2	B
14	+5V	B
15	GROUND 3	B
16	INHIBIT	B
17	TX DATA IN	B
18	TX $\overline{\text{DATA}}$ IN	B
19	GROUND 2	A
20	+5V	A
21	GROUND 3	A
22	INHIBIT	A
23	TX DATA IN	A
24	TX $\overline{\text{DATA}}$ IN	A

## CONFIGURATIONS AND ORDERING INFORMATION

Model No.	DESC No.	Receiver Data level	Case	Configuration
ACT 4454-201-1	5962-9206110HZC	Normally High	Flat Package	Dual
ACT 4454-201-2	5962-9206110HZA			
ACT 4460-201-1	5962-9206109HZC	Normally Low		
ACT 4460-201-2	5962-9206109HZA			

### FLAT PACKAGE CONFIGURATION

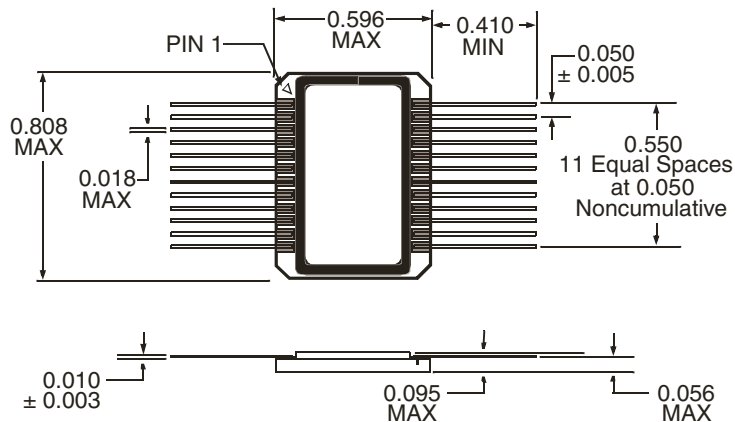

**PLAINVIEW, NEW YORK**  
 Toll Free: 800-THE-1553  
 Fax: 516-694-6715

**INTERNATIONAL**  
 Tel: 805-778-9229  
 Fax: 805-778-1980

**NORTHEAST**  
 Tel: 603-888-3975  
 Fax: 603-888-4585

**SE AND MID-ATLANTIC**  
 Tel: 321-951-4164  
 Fax: 321-951-4254

**WEST COAST**  
 Tel: 949-362-2260  
 Fax: 949-362-2266

**CENTRAL**  
 Tel: 719-594-8017  
 Fax: 719-594-8468

[www.aeroflex.com](http://www.aeroflex.com)    [info-ams@aeroflex.com](mailto:info-ams@aeroflex.com)



Aeroflex Microelectronic Solutions reserves the right to change at any time without notice the specifications, design, function, or form of its products described herein. All parameters must be validated for each customer's application by engineering. No liability is assumed as a result of use of this product. No patent licenses are implied.



Our passion for performance is defined by three attributes represented by these three icons: solution-minded, performance-driven and customer-focused