

Standard Products

ACT4462D Dual Transceiver Variable Amplitude Universal for H009 Specification or MacAir/1553/1760 Bus Operation

October 9, 2007

www.aeroflex.com/Avionics



FEATURES

- ACT4462D Dual Transceiver meets H009 and MacAir/1553/1760 specifications
- Variable output amplitude adjustment
- H009 or MacAir/MIL-STD-1553/MIL-STD-1760 – Pin selectable
- H009 transmitter can be used to drive clock signal line
- Bipolar $\pm 15V$ to $\pm 12V$ & Logic +5V Supplies
- Voltage source output
- Receiver thresholds adjustable – Using threshold adjustment pins
- 1.25"L x 0.61"W, 24 lead, ceramic, hermetic package
- Monolithic construction using linear ASICs
- Processed and screened to MIL-STD-883 specs
- Designed for commercial, industrial and aerospace applications
- Aeroflex is a Class H & K MIL-PRF-38534 manufacturer

DESCRIPTION

Aeroflex Plainview transceiver model ACT4462D is the first transceiver to combine H009 Bus and MacAir/1553/1760 Bus operation in a Variable Amplitude Dual Channel, pin selectable, hybrid. In addition to pin selectable bus operation the transceiver allows the user to externally set the receiver threshold, for either channel, to optimize system performance. Two pins, per channel, are brought out for external threshold adjustment, and, with the addition of a resistor from each pin to ground the threshold can be tailored for each channel separately. This Dual Channel, Variable Amplitude, Pin Selectable H009 or MacAir/1553/1760 Transceiver allows the user to stock one component when the system has both a H009 Bus as well as a MacAir/1553/1760 Bus. It should also appeal to H009/MacAir/1553/1760 test equipment manufacturers.

TRANSMITTER

H009 OPERATION

When the 1553/H009 select pin is tied to 5VDC, the transmitter is in H009 operation and accepts bi-phase TTL data at the input and when coupled to the data bus with a 1:1 transformer, isolated on the transceiver side with two 34 Ohm bus terminating resistors, with the bus terminated by a 170 Ohm resistor the data bus signal produced is 21Vp-p typical at A-A' (See Figure 9). When both DATA and $\overline{\text{DATA}}$ inputs are held low or high, the transmitter output becomes a low impedance and signal is "removed" from the line. In addition, an overriding "TX INHIBIT" input returns the output to a high impedance state. A logic "1" applied to the "TX INHIBIT" takes priority over the condition of the data inputs and disables the transmitter (See Transmitter Logic Waveforms - Figure 1). The transmitter utilizes an active filter to suppress harmonics above 1 MHz to meet H009 specifications. The transmitter may be safely operated for an indefinite period at 100% duty cycle into a data bus short circuit.

MacAIR/1553/1760 OPERATION

When the 1553/H009 select pin is left open circuit, the transmitter is in the MacAir/1553/1760 operation and accepts bi-phase TTL data at the input and when coupled to the data bus with a 1:1 transformer, isolated on the data bus side with two 55 Ohm fault isolation resistors, and loaded by two 70 Ohm terminations plus additional receivers, the data bus signal produced is 7.0Vp-p minimum at A-A' (See Figure 11 and 12).

When both DATA and $\overline{\text{DATA}}$ inputs are held low or high, the transmitter output becomes a high impedance and is "removed" from the line. In addition, an overriding "TX INHIBIT" input provides for the removal of the transmitter output from the line. A logic "1" applied to the "TX INHIBIT" takes priority over the condition of the data inputs and disables the transmitter (See Transmitter Logic Waveforms - Figure 3).

The transmitter utilizes an active filter to suppress harmonics above 1 MHz to meet MacAir specifications A-3818, A-4905, A-5232 and A-5690. The transmitter may be safely operated for an indefinite period at 100% duty cycle into a data bus short circuit.

The transmitter output level is controlled by an external DC Voltage of 0VDC to 10VDC for full output, regardless of the bus type selected. External ceramic coupling capacitors, with 10K Ω resistors connected in parallel to the capacitor (low ESR), are needed to connect the transmitter outputs to the primary of the coupling transformer.

The main difference between H009 transmitter operation and MacAir/1553/1760 transmitter operation is the Inhibit function (TX INHIBIT A/TX INHIBIT B). In H009 operation, when both the DATA and $\overline{\text{DATA}}$ transmitter inputs are held low or high, the transmitter output impedance is low, and there is no transmitter output signal. This function is used to terminate the bus, for a period of time, in a H009 system. When the TX INHIBIT is pulled up to 5VDC or left open circuited, the transmitter output goes into a high impedance state, effectively removing it from the bus.

RECEIVER

The Receiver section accepts bi-phase differential data at the input and produces two TTL signals at the output. The outputs are DATA and $\overline{\text{DATA}}$, and represent positive and negative excursions of the input beyond a pre-determined threshold (See Receiver Logic Waveforms - Figure 2 and 4). Since H009 and MacAir/1553/1760 bus thresholds are usually different, the receiver threshold levels for both channels can be set, for either bus operation, with the Threshold adjust pins. Grounding the DATA and $\overline{\text{DATA}}$ threshold adjust pins, for channel A or B, will set normal 1553 threshold levels of about 0.9Vp-p at 1MHz. By adding a resistor from each threshold pin to ground the receiver threshold level can be increased from normal 1553 levels to normal H009 levels of about 2Vp-p at 1MHz, or set anywhere in between.

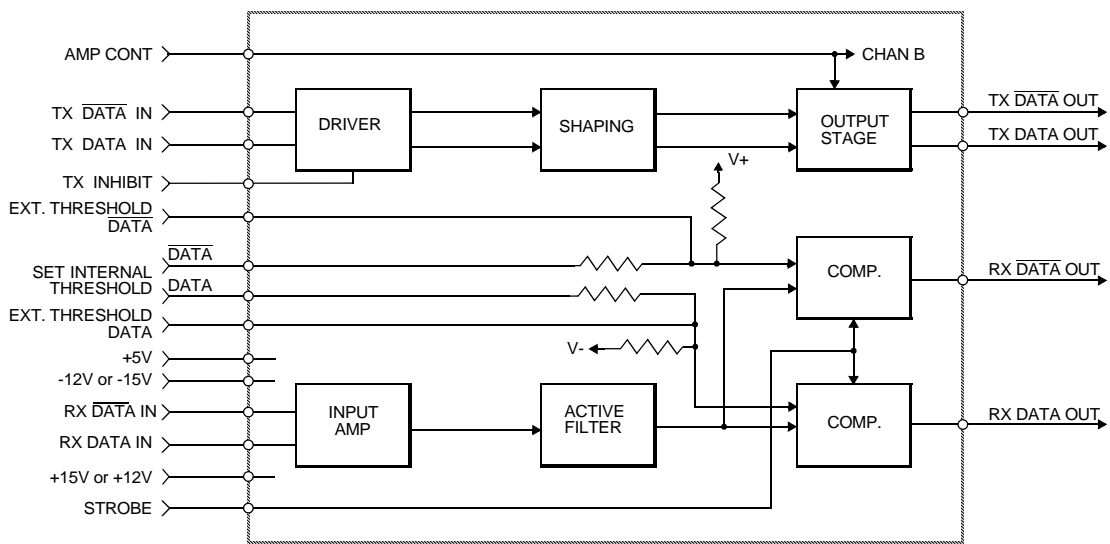

BLOCK DIAGRAM (WITHOUT TRANSFORMER)

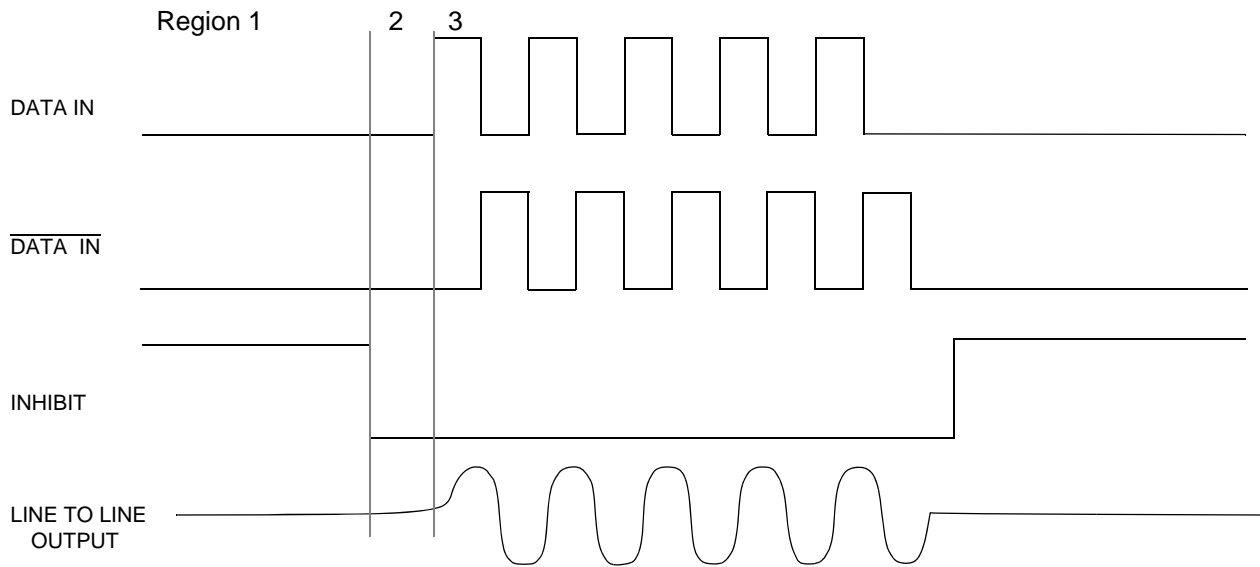

Notes: 1. Data and $\overline{\text{DATA}}$ inputs must be complementary waveforms or 50% duty cycle average, with no delays between them, and in the same state during the off time (both high and low).
 2. Region 1; no output signal, High Z state, (Receive Mode), Region 2; No Output signal, Low Z state, (Terminate Mode), Region 3; Transmitter signal on, low Z.

FIGURE 1 – H009 TRANSMITTER LOGIC WAVEFORMS

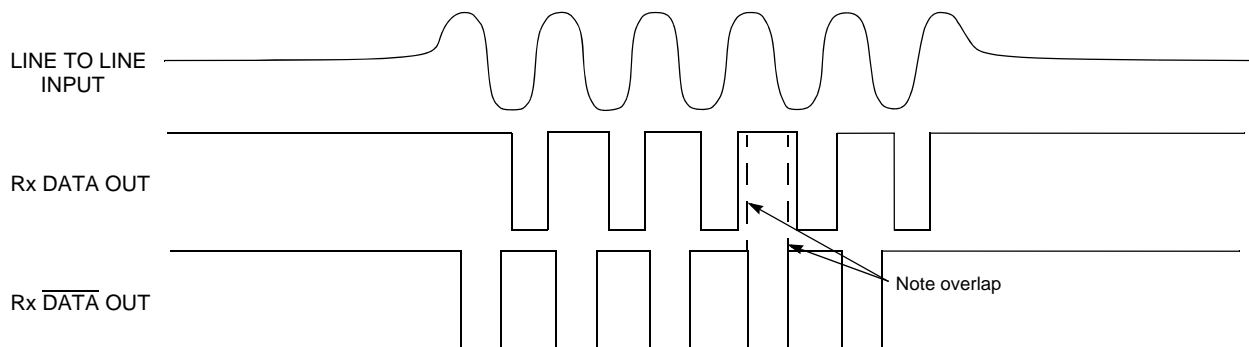
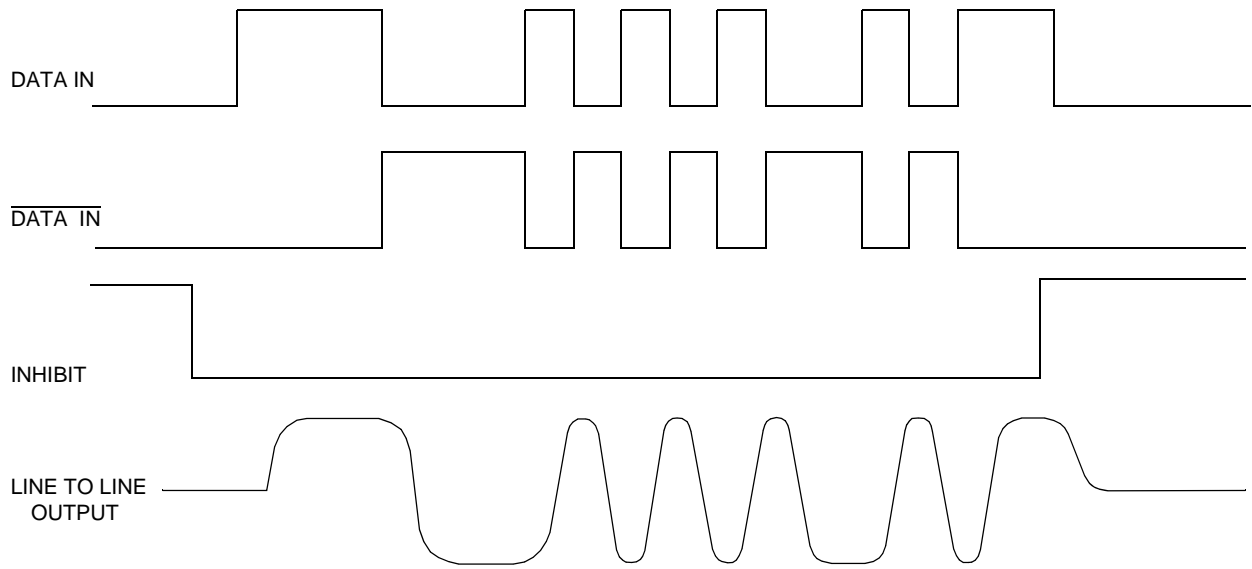

FIGURE 2 – H009 RECEIVER LOGIC WAVEFORMS – ACT4462DI



- Notes:
1. Line to line waveforms illustrate Macair signals, MIL-STD-1553 signals are trapezoidal.
 2. DATA and $\overline{\text{DATA}}$ inputs must be complementary waveforms or 50% duty cycle average, with no delays between them.
 3. DATA and $\overline{\text{DATA}}$ must be in the same state during off time (both high or low).

FIGURE 3 – MACAIR/1553 TRANSMITTER LOGIC WAVEFORMS

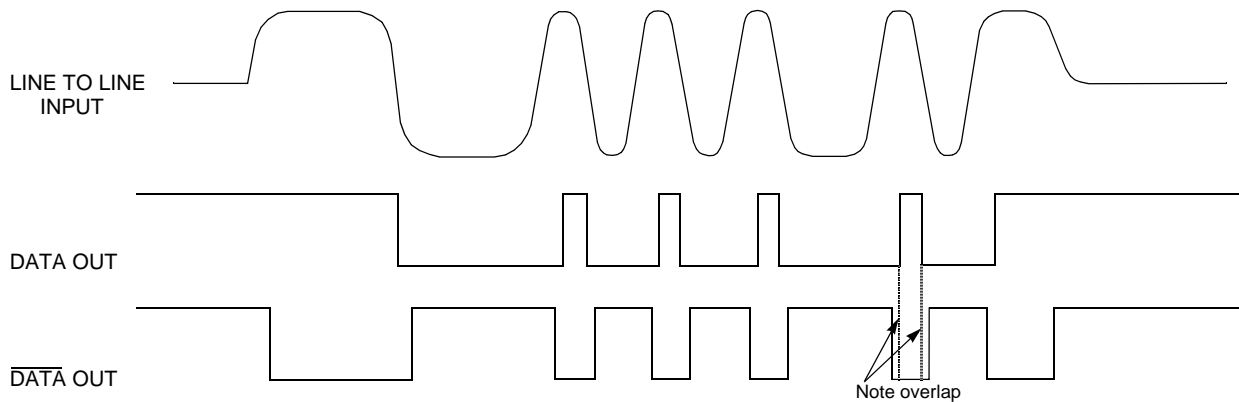

FIGURE 4 – MACAIR/1553 RECEIVER LOGIC WAVEFORMS – ACT4462DI

ABSOLUTE MAXIMUM RATINGS

Operating Case Temperature	-55°C to +125°C	
Storage Case Temperature	-65°C to +150°C	
Power Supply Voltages	±15 VDC P.S. to ±18 VDC MAX	+5 VDC P.S. to +7 VDC
Logic Input Voltage	-0.3 V to +5.5 V	
Receiver Differential Input	±40 V	
Receiver Input Voltage (Common Mode)	±10 V	
Driver Peak Output Current	150 mA	
Amplitude Control Voltage	-0.5 VDC to +0.5 VDC	
Total Package Power Dissipation over the Full Operating Case Temperature Range *	1553-3.25 Watt / H009 - 1.72 Watt (Note: Normal operation conditions require one transmitter on and the other off at any given time)	
Maximum Junction to Case Temperature (100% duty cycle) *	1553-16.25°C / H009 - 8.6°C	
Junction-Case, Thermal Resistance	5°C/W	

* Macair-1553/H009

ELECTRICAL CHARACTERISTICS – DRIVER SECTION

INPUT CHARACTERISTICS, TX DATA IN OR TX DATA IN (H009, MACAIR & MIL-STD-1553)

PARAMETER	CONDITION	SYMBOL	MIN	TYP	MAX	UNIT
"0" Input Current	$V_{IN} = 0.4V$	I_{ILD}	-	-0.2	-0.4	mA
"1" Input Current	$V_{IN} = 2.7V$	I_{IHD}	-	1	40	μA
"0" Input Voltage		V_{ILD}	-	-	0.7	V
"1" Input Voltage		V_{IHD}	2.0	-	-	V

INHIBIT CHARACTERISTICS (H009, MACAIR & MIL-STD-1553)

"0" Input Current	$V_{IN} = 0.4V$	I_{ILI}	-	-0.2	-0.4	mA
"1" Input Current	$V_{IN} = 2.7V$	I_{IHI}	-	1.0	40	μA
"0" Input Voltage		V_{ILI}	-	-	0.7	V
"1" Input Voltage		V_{IHI}	2	-	-	V
Delay from TX inhibit, (0→1) to inhibited output	Note 1	t_{DXOFF}	-	200	500	nS
Delay from TX inhibit, (1→0) to active output	Note 1	t_{DXON}	-	250	700	nS
Differential Output Noise, inhibit mode		V_{NOI}	-	0.8	10	mVp-p
Differential Output Impedance (inhibited)	Note 2	Z_{OI}	10K	-	-	Ω
Amplitude Control Voltage Input Current Input Resistance	$V_{CTL} = 10V$ -	V_{ICTL} Z_O	- 10K	1.0 -	- -	mA Ω

ELECTRICAL CHARACTERISTICS – DRIVER SECTION con't

OUTPUT CHARACTERISTICS (H009)

PARAMETER	CONDITION	SYMBOL	MIN	TYP	MAX	UNIT
Differential output level at point A-A' on Figure 9	$R_L=170\ \Omega$ (Pin 21 set at +10VDC)	V_O	16	21	24	Vp-p
Rise and fall times (10% to 90% of p-p output)		t_r	200	-	300	nS
Output offset at point A-A' on Figure 9, 2.5 μ S after midpoint crossing of the last bit	$R_L=170\ \Omega$	V_{OS}	-	-	± 265	mVpeak
Delay from 50% point of TX DATA or TX DATA input to zero crossing of differential signal (Note 1)		t_{DTX}	-	270	400	nS

OUTPUT CHARACTERISTICS (Macair & MIL-STD-1553/1760)

Differential output Level, Figure 11 Point B-B'	$Z_O = 70\ \Omega$ (Pin 21 set at +10VDC)	V_O	20	21	24	Vp-p
Output offset at point A-A on Figures 11 or 12, 2.5 μ S after midpoint crossing of the last bit		V_{OS}	-	-	± 90	mVpeak
Output rise / fall times (10% to 90% of p-p output)		t_R & t_F	200	250	300	nS
Delay from 50% point of TX DATA or TX DATA input to zero crossing of differential output (Note 1)		t_{DTX}	-	270	400	nS

ELECTRICAL CHARACTERISTICS – RECEIVER SECTION (H009, MACAIR & MIL-STD-1553)

PARAMETER	CONDITION	SYMBOL	MIN	TYP	MAX	UNIT
Differential Input Impedance (Note 1)	$f = 1\text{MHz}$	Z_{IN}	20K	-	-	Ω
Differential Input Voltage Range		V_{IDR}	-	-	40	Vp-p
Input Common Mode Voltage Range	Note 1	V_{ICR}	10	-	-	Vp-p
Common Mode Rejection Ratio	Point A-A on Figure 12	CMRR	40	-	-	dB

STROBE CHARACTERISTICS (LOGIC "0" INHIBITS OUTPUT)

"0" Input Current	$V_S = 0.4\text{V}$	I_{IL}	-	-0.2	-0.4	mA
"1" Input Current	$V_S = 2.7\text{V}$	I_{IH}	-	1	+40	μ A
"0" Input Voltage		V_{IL}	-	-	0.7	V
"1" Input Voltage		V_{IH}	2.0	-	-	V
Strobe Delay (turn-on or turn-off)		$t_{SD(ON)}$	-	-	150	nS

THRESHOLD CHARACTERISTICS (SINEWAVE INPUT)

Internal Threshold Voltage						
H009 – Figure 9 $R \sim 3.4\text{K}\Omega$	100K - 1MHz	V_{TH}	1.2	1.8	2.3	Vp-p
MacAir/1553 – Figure 11 or 12, Point A - A'			0.70	0.90	1.10	Vp-p

OUTPUT CHARACTERISTICS, RX DATA AND RX DATA

"1" State	$I_{OH} = -0.4\text{mA}$	V_{OH}	2.5	3.6	-	V
"0" State	$I_{OL} = 4\text{mA}$	V_{OL}	-	0.35	0.5	V
Delay, (average) from differential input zero crossings to RX DATA and RX DATA output	50% points	t_{DRX}	-	275	450	nS

POWER SUPPLY CURRENT (Macair & MIL-STD-1553/1760) 1/ 2/

DUTY CYCLE	CONDITION	SYMBOL	TYP	MAX	UNIT
Transmitter Standby	Point B-B', $Z_O = 70 \Omega$, $V_O = 29 \text{ VP-P}$ Bit Pattern = FFFF _{HEX} Figure 12 (Pin 21 set at +10VDC)	I_{CC}	5	10	mA
		I_{EE}	25	35	
		I_L	18	30	
25%		I_{CC}	20	30	
		I_{EE}	40	60	
		I_L	18	30	
50%		I_{CC}	40	60	
		I_{EE}	60	80	
		I_L	18	30	
100%		I_{CC}	85	120	
		I_{EE}	105	140	
		I_L	18	30	

POWER SUPPLY CURRENT (H009)

DUTY CYCLE	CONDITION	SYMBOL	TYP	MAX	UNIT
Transmitter Standby	Point A-A', $Z_O = 170\Omega$, $V_O = 21 \text{ VP-P}$ Bit Pattern = FFFF _{HEX} Figure 9 (Pin 21 set at +10VDC)	I_{CC}	5	10	mA
		I_{EE}	15	35	
		I_L	18	30	
25%		I_{CC}	17	23	
		I_{EE}	27	33	
		I_L	18	30	
50%		I_{CC}	27	35	
		I_{EE}	37	45	
		I_L	18	30	
100%		I_{CC}	42	60	
		I_{EE}	56	70	
		I_L	18	30	

Notes:

1. Characteristics guaranteed by design, not production tested.
2. Measured at 1mHz at point A-A', power on or off.
3. Specifications apply over the temperature range of -55°C to +125°C (case temperature) unless otherwise noted.
4. All typical values are measured at +25°C.
5. Amplitude control set at +10V for electrical characteristics tables.
6. Normal operating supplies: ±15VDC to ±12VDC and +5VDC.

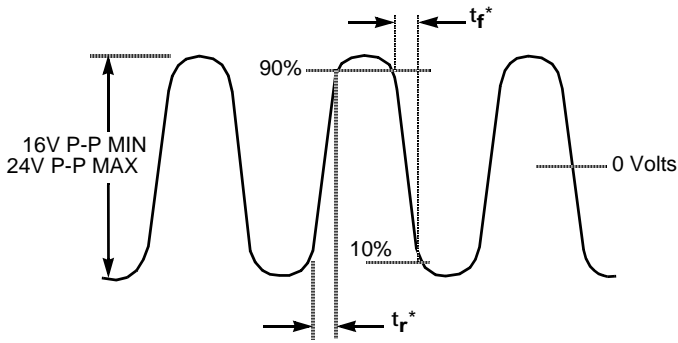

* Rise and fall times measured at point A-A' in Fig 9 & 12

FIGURE 5 – TRANSMITTER (TX) OUTPUT WAVEFORM

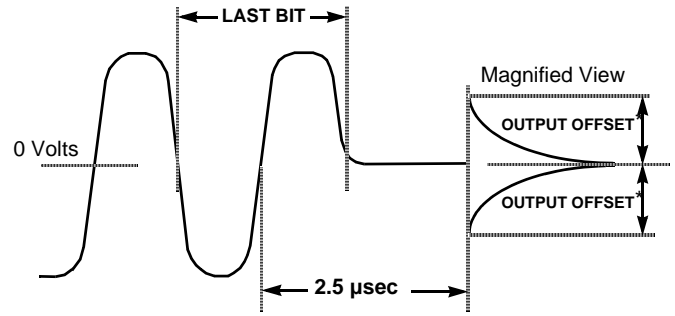

*Offset measured at point A-A' in Fig 9 & 12

FIGURE 6 – TRANSMITTER (TX) OUTPUT OFFSET

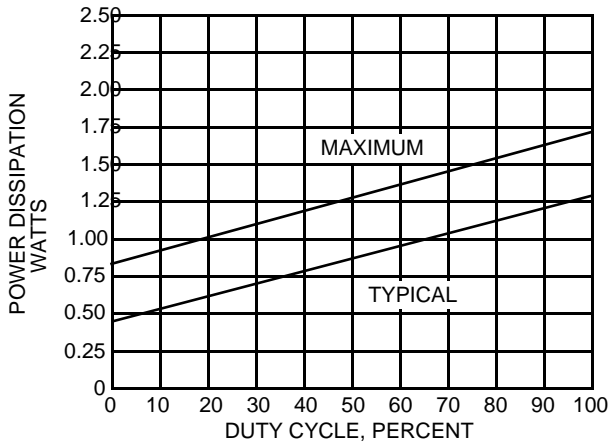

FIGURE 7 – H09 POWER DISSIPATION vs DUTY CYCLE (Total hybrid with one channel transmitting and the other in standby)

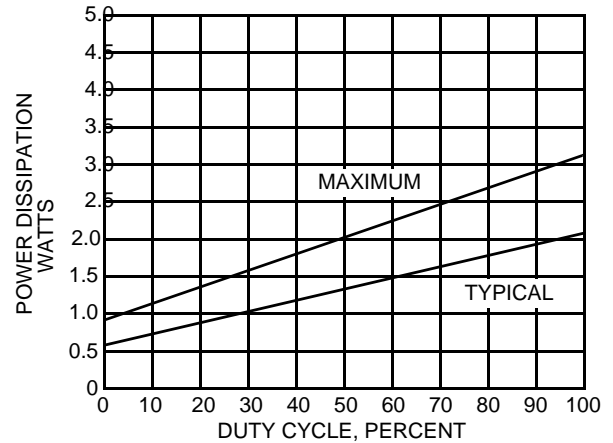

FIGURE 8 – MACAIR/1553 POWER DISSIPATION vs DUTY CYCLE (Total hybrid with one channel transmitting and the other in standby)

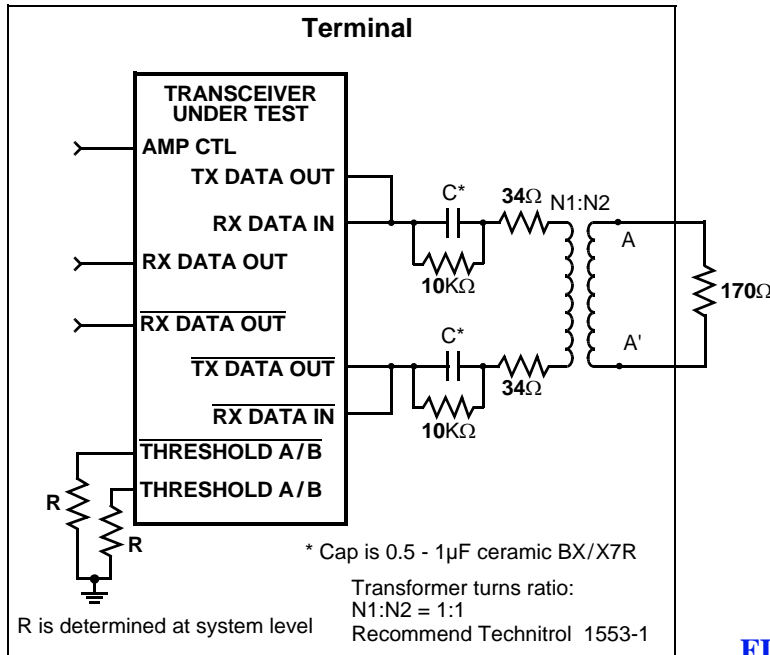

FIGURE 9 – H09 TYPICAL TRANSFORMER CONNECTION

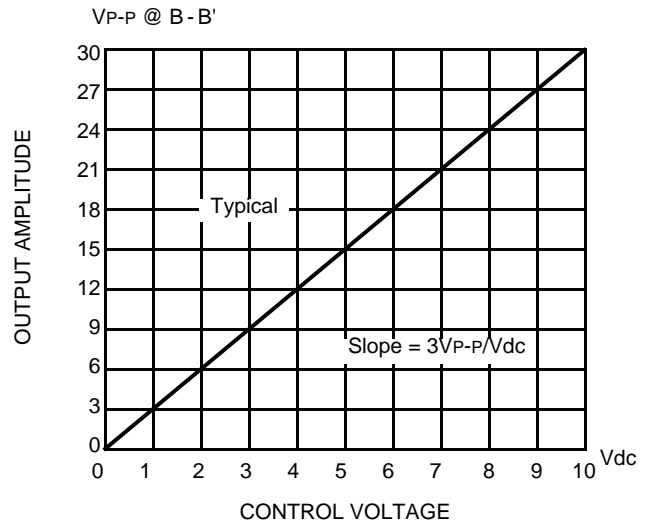

FIGURE 10 – TRANSMITTER (TX) OUTPUT AMPLITUDE vs CONTROL VOLTAGE (See Figure 12 herein)

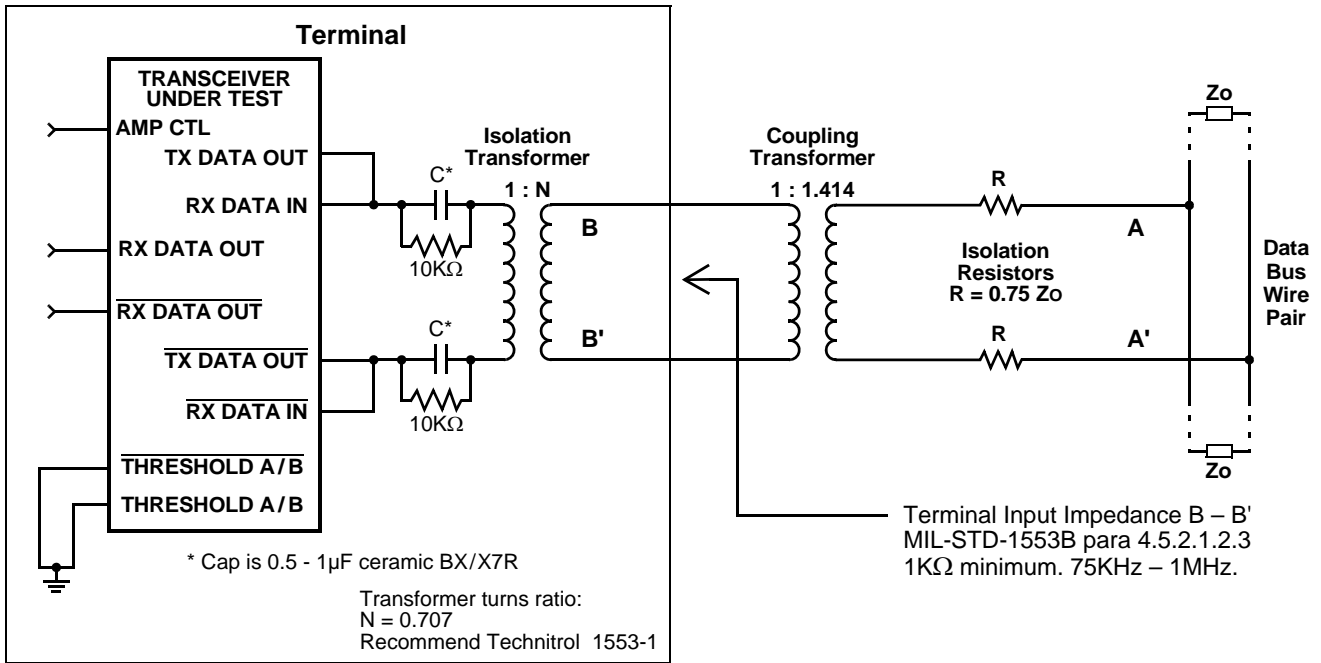

FIGURE 11 – MACAIR/1553 DATABUS INTERFACE USING TRANSFORMER COUPLING (FIGURE 9 OF MIL-STD-1553B)

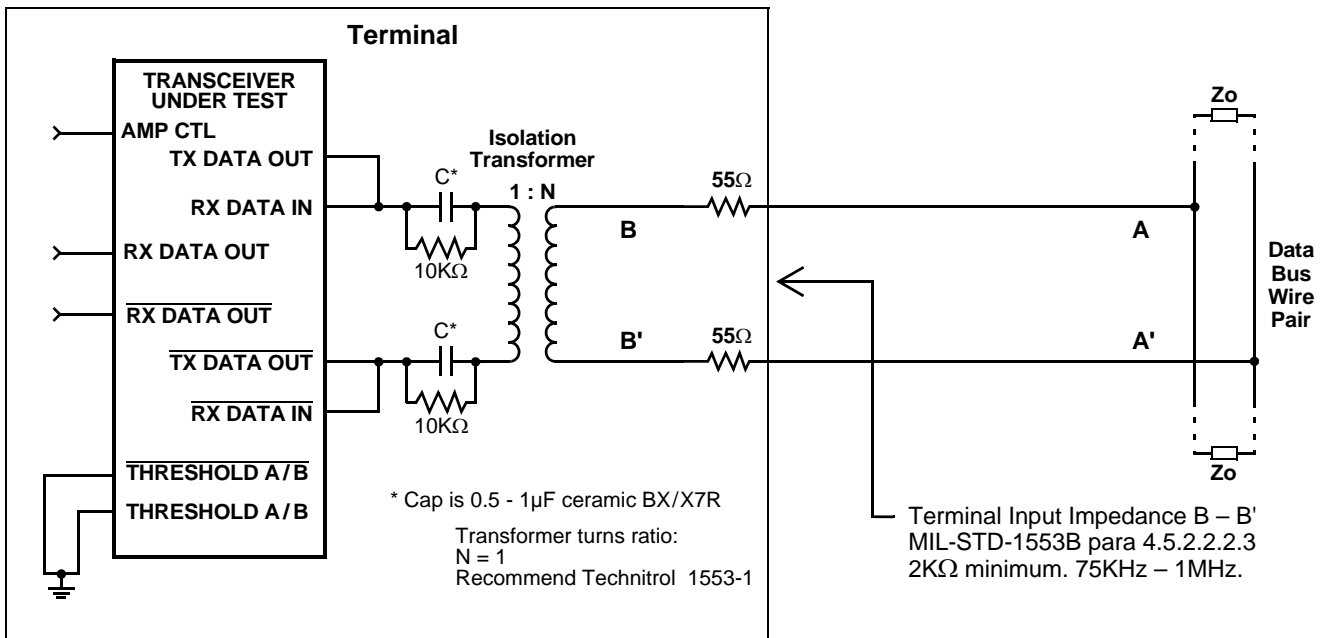
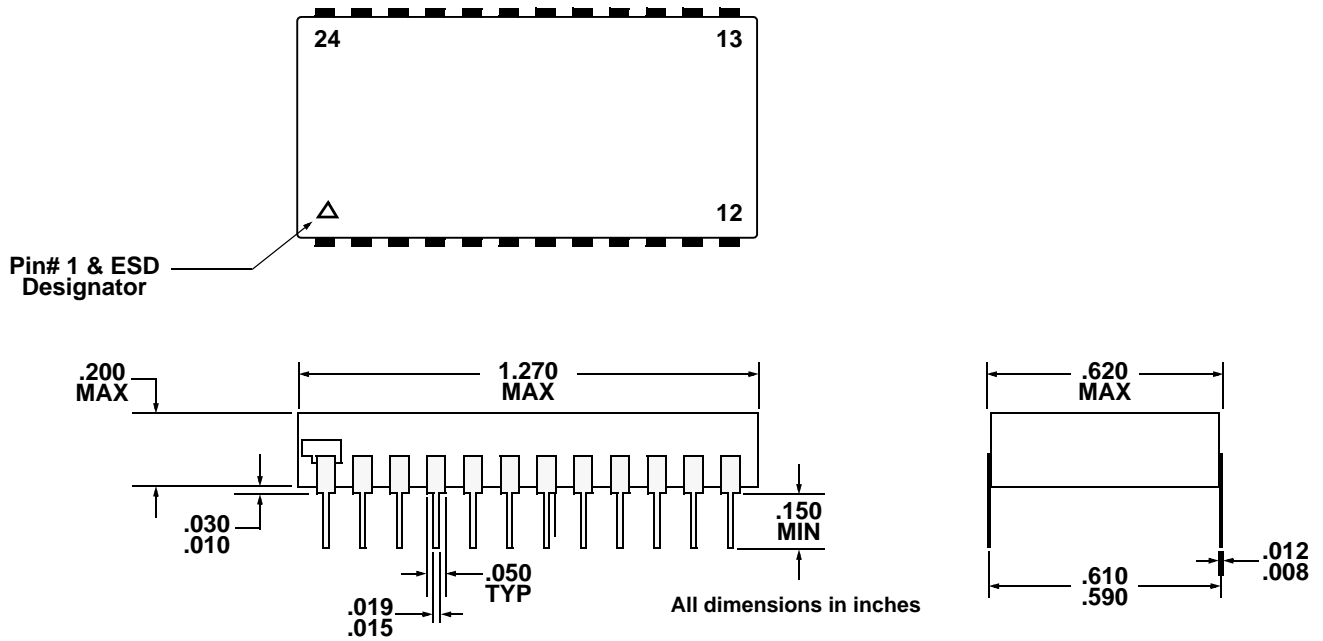

FIGURE 12 – MACAIR/1553 DATABUS INTERFACE USING DIRECT COUPLING (FIGURE 10 OF MIL-STD-1553B)

PACKAGE CONFIGURATION OUTLINE



PIN # vs FUNCTION TABLE

PIN #	FUNCTION	PIN #	FUNCTION
1	TX $\overline{\text{DATA}}$ IN A	13	THRESHOLD B
2	TX DATA IN A	14	$\overline{\text{THRESHOLD}}$ B
3	TX DATA OUT A / RX DATA IN A	15	TX INHIBIT B
4	TX $\overline{\text{DATA}}$ OUT A / RX $\overline{\text{DATA}}$ IN A	16	1553 / H009 SELECT
5	RX DATA OUT A	17	+VL (+5V)
6	RX $\overline{\text{DATA}}$ OUT A	18	GROUND
7	TX $\overline{\text{DATA}}$ IN B	19	VEE (-15V)
8	TX DATA IN B	20	VCC (+15V)
9	TX DATA OUT B / RX DATA IN B	21	AMPL CONTROL
10	TX $\overline{\text{DATA}}$ OUT B / RX $\overline{\text{DATA}}$ IN B	22	THRESHOLD A
11	RX DATA OUT B	23	$\overline{\text{THRESHOLD}}$ A
12	RX $\overline{\text{DATA}}$ OUT B	24	TX INHIBIT A

CONFIGURATIONS AND ORDERING INFORMATION

MODEL NO.	RECEIVER DATA LEVEL	CASE	SPECS.
ACT 4462D	Normally Low	Plug In	H009 (-55°C to +125°C) MacAir/1553/1760 (-55°C to +125°C) MIL-PRF-38534 Class H Processing
ACT 4462DI	Normally High		
ACT 4462D-7	Normally Low		H009 & MacAir/1553/1760 Commercial flow, +25°C testing only
ACT 4462DI-7	Normally High		

Note:

1. Reference Aeroflex ACT4444 for new 1553/McAir designs requiring a miniature chip scale surface mount component implementation.

PLAINVIEW, NEW YORK
Toll Free: 800-THE-1553
Fax: 516-694-6715

INTERNATIONAL
Tel: 805-778-9229
Fax: 805-778-1980

NORTHEAST
Tel: 603-888-3975
Fax: 603-888-4585

SE AND MID-ATLANTIC
Tel: 321-951-4164
Fax: 321-951-4254

WEST COAST
Tel: 949-362-2260
Fax: 949-362-2266

CENTRAL
Tel: 719-594-8017
Fax: 719-594-8468

www.aeroflex.com info-ams@aeroflex.com



Aeroflex Microelectronic Solutions reserves the right to change at any time without notice the specifications, design, function, or form of its products described herein. All parameters must be validated for each customer's application by engineering. No liability is assumed as a result of use of this product. No patent licenses are implied.



Our passion for performance is defined by three attributes represented by these three icons: solution-minded, performance-driven and customer-focused