

FEATURES

- Pass Apple MFi Test
- 40V Input Voltage Surge
- 4.5V-36V Operational Input Voltage
- Dual 5.1V Outputs with 1% Accuracy
- Up to 3.5A Output Current
- 2.65A Constant Current Regulation for VOUT1
- 1.2A Constant Current Regulation for VOUT2
- USB Auto-detect Support Apple 2.4A, Samsung and BC1.2 Devices
- Hiccup Mode Protection at Output Short
- 90% Efficiency at Full Load
- 0.5mA Low Standby Input Current
- 5.7V Output Over Voltage Protection
- Cord Voltage Drop Compensation
- Meet EN55022 Class B Radiated EMI Standard
- 8kV ESD HBM Protection on DP and DM
- SOP-8EP Package

APPLICATIONS

- Car Charger
- Cigarette Lighter Adaptor (CLA)
- Rechargeable Portable Device
- CV/CC regulation DC/DC converter

GENERAL DESCRIPTION

ACT4525 is a wide input voltage, high efficiency step-down DC/DC converter that operates in either CV (Constant Output Voltage) mode or CC (Constant Output Current) mode. ACT4525 has separated output current limits for dual port CLA applications. With the separated current limits, the CLA can meet Apple's MFi standard. ACT4525 provides up to 3.5A output current at 125kHz switching frequency. ACT4525 builds in USB auto-detect algorithms to recognize Apple, Samsung, and BC1.2 devices to ensure maximum charge current to attached devices. ACT4525 utilize adaptive drive technique to achieve good EMI performance while main 90% efficiency at full load for mini size CLA designs. ACT4525 also built in output short circuit protection with hiccup mode. The average output current is reduced to below 6mA when output is shorted to ground. Other features include output over voltage protection and thermal shutdown.

The devices are available in a SOP-8EP package and require very few external devices for operation.

Typical Application Circuit

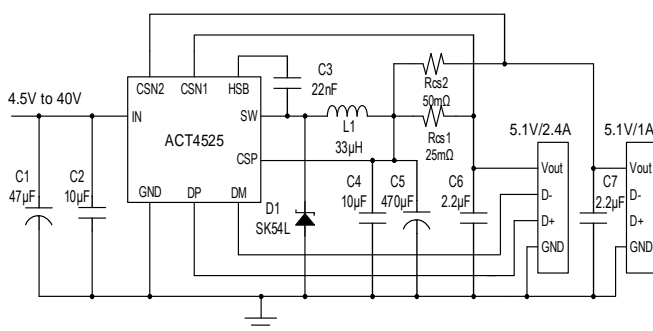

V/I Profile

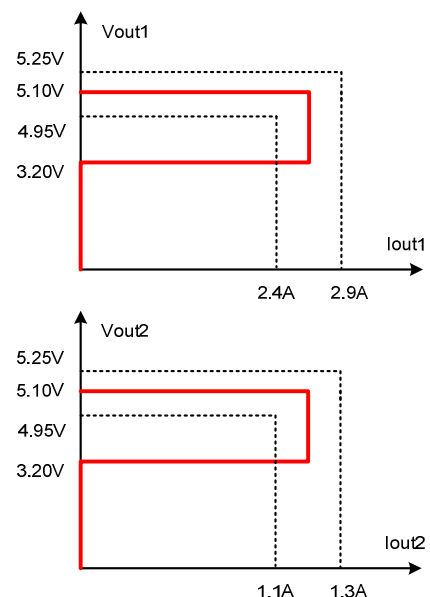

* Patent Pending

ORDERING INFORMATION

| PART NUMBER | OPERATION TEMPERATURE RANGE | PACKAGE | FREQUENCY | CORD COMP | PACKING |
|-----------------|-----------------------------|---------|-----------|-----------|-------------|
| ACT4525YH-T | -40°C to 85°C | SOP-8EP | 125kHz | 100mV | TAPE & REEL |
| ACT4525YH-T0001 | -40°C to 85°C | SOP-8EP | 125kHz | 200mV | TAPE & REEL |

PIN CONFIGURATION

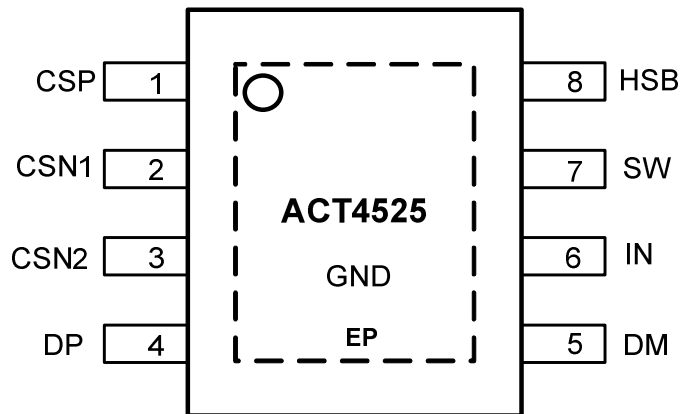

SOP-8EP

Top View

PIN DESCRIPTIONS

| PIN | NAME | DESCRIPTION |
|-----|------|--|
| 1 | CSP | Voltage Feedback Input. Connect to node of the inductor and output capacitor. CSP, CSN1 and CSN2 Kelvin sensing is recommended. |
| 2 | CSN1 | Output current sense negative input. Connect to the negative terminal of current sense resistor for VOUT1. |
| 3 | CSN2 | Output current sense negative input. Connect to the negative terminal of current sense resistor for VOUT2. |
| 4 | DP | Data Line Positive Input. Connected to D+ of attached portable device data line. This pin passes 8kV HBM ESD. |
| 5 | DM | Data Line Negative Input. Connected to D- of attached portable device data line. This pin passes 8kV HBM ESD. |
| 6 | IN | Power Supply Input. Bypass this pin with a 10 μ F ceramic capacitor to GND, placed as close to the IC as possible. |
| 7 | SW | Power Switching Output to External Inductor. |
| 8 | HSB | High Side Bias Pin. This provides power to the internal high-side MOSFET gate driver. Connect a 22nF capacitor from HSB pin to SW pin. |
| 9 | GND | Ground and Heat Dissipation Pad. Connect this exposed pad to large ground copper area with copper and vias. |

ABSOLUTE MAXIMUM RATINGS^①

| PARAMETER | VALUE | UNIT |
|--|--------------------------------|----------------|
| IN to GND | -0.3 to 40 | V |
| SW to GND | -1 to $V_{IN} + 1$ | V |
| HSB to GND | $V_{SW} - 0.3$ to $V_{SW} + 7$ | V |
| CSP, CSN1, CSN2, DP, DM to GND | -0.3 to +6 | V |
| Junction to Ambient Thermal Resistance | 46 | $^{\circ}$ C/W |
| Operating Junction Temperature | -40 to 150 | $^{\circ}$ C |
| Storage Junction Temperature | -55 to 150 | $^{\circ}$ C |
| Lead Temperature (Soldering 10 sec.) | 300 | $^{\circ}$ C |

①: Do not exceed these limits to prevent damage to the device. Exposure to absolute maximum rating conditions for long periods may affect device reliability.

ELECTRICAL CHARACTERISTICS

($V_{IN} = 12V$, $T_A = 25^\circ C$, unless otherwise specified.)

| Parameter | Symbol | Condition | Min | Typ | Max | Units |
|--|-----------|-----------------------------|------|------|------|-------|
| Input Over Voltage Protection | VIN_OVP | Rising | 40 | 42 | 44 | V |
| Input Over Voltage Hysteresis | | | | 4 | | V |
| Input Over Voltage Response Time | T_VIN_OVP | VIN step from 30V to 45V | | 250 | | ns |
| Input Under Voltage Lockout (UVLO) | VIN | Rising | | 4.5 | | V |
| Input UVLO Hysteresis | | | | 200 | | mV |
| Input Voltage Power Good Deglitch Time | | No OVP | | 40 | | ms |
| Input Voltage Power Good Deglitch Time | | No UVP | | 10 | | us |
| Input Standby Current | | Vin=12V, Vout=5.1V, Iload=0 | | 500 | | uA |
| Output Voltage Regulation | CSP | | 5.05 | 5.1 | 5.15 | V |
| Output Over Voltage Protection (OVP) | | Output rising | | 5.7 | | V |
| Output Over Voltage Deglitch Time | | | | 1.0 | | us |
| Output Voltage Load Compensation | | ACT4525-T Iout=2.4A | -15% | 100 | +15% | mV |
| | | ACT4525-T0001 Iout=2.4A | -15% | 200 | +15% | mV |
| Output Under Voltage Protection (UVP) | VOUT | VOUT falling | -10% | 3.2 | 10% | V |
| UVP Hysteresis | VOUT | VOUT rising | | 0.2 | | V |
| UVP Deglitch Time | VOUT | | | 10 | | us |
| UVP Blanking Time at Startup | | | | 3.5 | | ms |
| Output Constant Current Limit | CC1 | Rcs=25mΩ | 2.50 | 2.65 | 2.80 | A |
| | CC2 | Rcs=50mΩ | 1.1 | 1.2 | 1.3 | A |
| Hiccup Waiting Time | | | | 4.13 | | s |
| Top FET Cycle by Cycle Current Limit | | | 4.5 | 5.8 | | A |
| Top FET Rdson | | | | 70 | | mΩ |
| Bottom FET Rdson | | | | 4.7 | | Ω |
| Maximum Duty Cycle | | | 99 | | | % |
| Switching Frequency | | | -10% | 125 | +10% | kHz |
| Soft-start Time | | | | 2.0 | | ms |

ELECTRICAL CHARACTERISTICS

($V_{IN} = 12V$, $T_A = 25^{\circ}C$, unless otherwise specified.)

| Parameter | Symbol | Condition | Min | Typ | Max | Units |
|------------------------------|--------------|---|------|------|------|-------------|
| Out Voltage Ripples | | $C_{out}=470\mu F/22\mu F$ ceramic | | 80 | | mV |
| Line Transient Response | | Input 12V-40V-12V with 1V/ μs slew rate, $V_{out}=5V$, $I_{load}=0A$ and 2.4A | 4.75 | | 5.25 | V |
| Load Transient Response | $V_{out}=5V$ | 80mA-1.0A-80mA load with 0.1A/ μs slew rate | 4.9 | 5.15 | 5.4 | V |
| Thermal Shut Down | | | | 160 | | $^{\circ}C$ |
| Thermal Shut Down Hysteresis | | | | 30 | | $^{\circ}C$ |
| ESD of DP, DM | | HBM | | 8 | | kV |

FUNCTIONAL BLOCK DIAGRAM

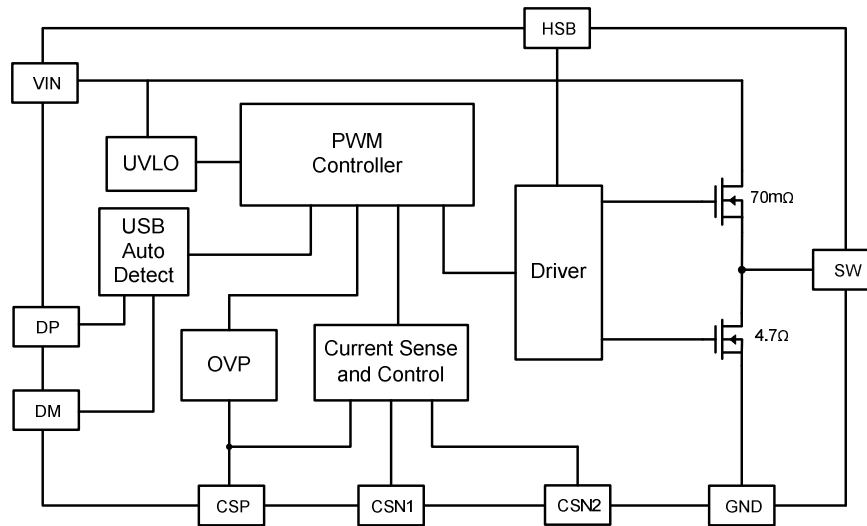

FUNCTIONAL DESCRIPTION

Output Current Sensing and Regulation

Sense resistor is connected to CSP and CSN1, CSN2 respectively. The sensed differential voltages are compared with interval references to regulate currents. CC loop and CV loop are in parallel. The current loop response is allowed to have slower response compared to voltage loop. However, during current transient response, the inductor current overshoot/undershoot should be controlled within +/-25% to avoid inductor saturation.

Cycle-by-Cycle Current Control

The conventional cycle-by-cycle peak current mode is implemented with high-side FET current sense.

Input Over Voltage Protection

The converter is disabled if the input voltage is above 42V (+/-2V). Device resumes operation automatically 40ms after OVP is cleared.

Output Over Voltage Protection

Device stops switching when output over-voltage is sensed, and resumes operation automatically when output voltage drops to OVP - hysteresis.

Output Under-Voltage Protection / Hiccup Mode

There is a under voltage protection (UVP) threshold. If the UVP threshold is hit for 10us, an over current or short circuit is assumed, and the converter goes into hiccup mode by disabling the converter and restarts after hiccup waiting period.

Cord Compensation

In some applications, the output voltage is increased with output current to compensate the potential voltage drop across output cable. The compensation is based on the high side feedback resistance.

The compensation voltage is derived as:

$$\Delta V_{out} = (V_{CSP} - V_{CSN}) * K$$

$$ACT4525YH-T \quad K=1.515$$

$$ACT4525YH-T0001 \quad K=3.030$$

This voltage difference could be added on the reference or turning the $(V_{CSP} - V_{CSN})$ voltage into a sink current at FB pin to pull Vout higher than programmed voltage.

The cord compensation loop should be very slow to avoid potential disturbance to the voltage loop. The voltage loop should be sufficiently stable on various cord compensation setting.

Thermal Shutdown

If the T_J increases beyond 160°C, ACT4525 goes into HZ mode and the timer is preserved until T_J drops by 30°C.

APPLICATIONS INFORMATION

Inductor Selection

The inductor maintains a continuous current to the output load. This inductor current has a ripple that is dependent on the inductance value.

Higher inductance reduces the peak-to-peak ripple current. The trade off for high inductance value is the increase in inductor core size and series resistance, and the reduction in current handling capability. In general, select an inductance value L based on ripple current requirement:

$$L = \frac{V_{OUT} \times (V_{IN} - V_{OUT})}{V_{IN} f_{SW} I_{LOADMAX} K_{RIPPLE}} \quad (1)$$

Where V_{IN} is the input voltage, V_{OUT} is the output voltage, f_{SW} is the switching frequency, $I_{LOADMAX}$ is the maximum load current, and K_{RIPPLE} is the ripple factor. Typically, choose $K_{RIPPLE} = 30\%$ to correspond to the peak-to-peak ripple current being 30% of the maximum load current.

With a selected inductor value the peak-to-peak inductor current is estimated as:

$$I_{LPK-PK} = \frac{V_{OUT} \times (V_{IN} - V_{OUT})}{L \times V_{IN} \times f_{SW}} \quad (2)$$

The peak inductor current is estimated as:

$$I_{LPK} = I_{LOADMAX} + \frac{1}{2} I_{LPK-PK} \quad (3)$$

The selected inductor should not saturate at I_{LPK} . The maximum output current is calculated as:

$$I_{OUTMAX} = I_{LIM} - \frac{1}{2} I_{LPK-PK} \quad (4)$$

I_{LIM} is the internal current limit.

Input Capacitor

The input capacitor needs to be carefully selected to maintain sufficiently low ripple at the supply input of the converter. A low ESR capacitor is highly recommended. Since large current flows in and out of this capacitor during switching, its ESR also affects efficiency.

The input capacitance needs to be higher than 10 μ F. The best choice is the ceramic type. However, low ESR tantalum or electrolytic types may also be used provided that the RMS ripple current rating is higher than 50% of the output current. The input capacitor should be placed close to the IN and GND pins of the IC, with the shortest traces possible. In the case of tantalum or electrolytic types, a ceramic capacitor is

recommended to parallel with tantalum or electrolytic capacitor, which should be placed right next to the IC.

Output Capacitor

The output capacitor also needs to have low ESR to keep low output voltage ripple. The output ripple voltage is:

$$V_{RIPPLE} = I_{OUTMAX} K_{RIPPLE} R_{ESR} + \frac{(V_{IN} - V_{OUT}) \times V_{OUT}}{8 \times f_{SW}^2 L C_{OUT} \times V_{IN}} \quad (5)$$

Where I_{OUTMAX} is the maximum output current, K_{RIPPLE} is the ripple factor, R_{ESR} is the ESR of the output capacitor, f_{SW} is the switching frequency, L is the inductor value, and C_{OUT} is the output capacitance. In the case of ceramic output capacitors, R_{ESR} is very small and does not contribute to the ripple. Therefore, a lower capacitance value can be used for ceramic type. In the case of tantalum or electrolytic capacitors, the ripple is dominated by R_{ESR} multiplied by the ripple current. In that case, the output capacitor is chosen to have sufficiently low ESR.

For ceramic output capacitor, typically choose a capacitance of about 22 μ F. For tantalum or electrolytic capacitors, choose a capacitor with less than 50m Ω ESR. If an 330 μ F or 470 μ F electrolytic capacitor is used, where ripple is dominantly caused by ESR, an 2.2 μ F ceramic in parallel is recommended.

Rectifier Schottky Diode

Use a Schottky diode as the rectifier to conduct current when the High-Side Power Switch is off. The Schottky diode must have current rating higher than the maximum output current and a reverse voltage rating higher than the maximum input voltage. Further more, the low forward voltage Schottky is preferable for high efficiency and smoothly operation.

APPLICATIONS INFORMATION

Current Sense Resistor

The traces leading to and from the sense resistor can be significant error sources. With small value sense resistors, trace resistance shared with the load can cause significant errors. It is recommended to connect the sense resistor pads directly to the CSP and CSN pins using “Kelvin” or “4-wire” connection techniques as shown below.

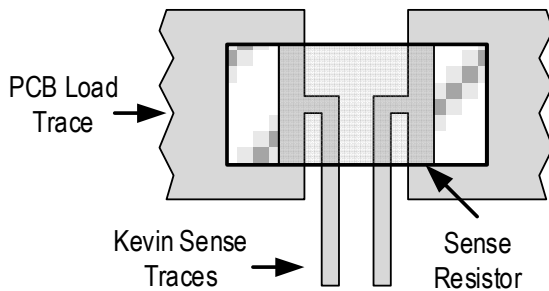

Current Limit Setting

If output current hits current limit, output voltage drops to keep the current to a constant value.

The following equation calculates the constant current limit.

For output1:

$$I_{Limit} (A) = \frac{66mV}{R_{cs} (m\Omega)} \quad (6)$$

For output2:

$$I_{Limit} (A) = \frac{60mV}{R_{cs} (m\Omega)} \quad (7)$$

Where R_{cs} is current sense resistor.

APPLICATIONS INFORMATION

PCB Layout Guidance

When laying out the printed circuit board, the following checklist should be used to ensure proper operation of the IC.

- 1) Arrange the power components to reduce the AC loop size consisting of C_{IN} , V_{IN} pin, SW pin and the Schottky diode.
- 2) The high power loss components, e.g. the controller, Schottky diode, and the inductor should be placed carefully to make the thermal spread evenly on the board.
- 3) Place input decoupling ceramic capacitor C_{IN} as close to V_{IN} pin as possible. C_{IN} should be connected to power GND with several vias or short and wide copper trace.
- 4) Schottky anode pad and IC exposed pad should be placed close to ground clips in CLA applications.
- 5) Use “Kelvin” or “4-wire” connection techniques from the sense resistor pads directly to the CSP and CSN1, CSN2 pins. The CSP and CSN1, CSN2 traces should be in parallel to avoid interference.
- 6) Place multiple vias between top and bottom GND planes for best heat dissipation and noise immunity.
- 7) Use short traces connecting HSB- C_{HSB} -SW loop.
- 8) SW pad is noise node switching from V_{IN} to GND. It should be isolated away from the rest

Example PCB Layout

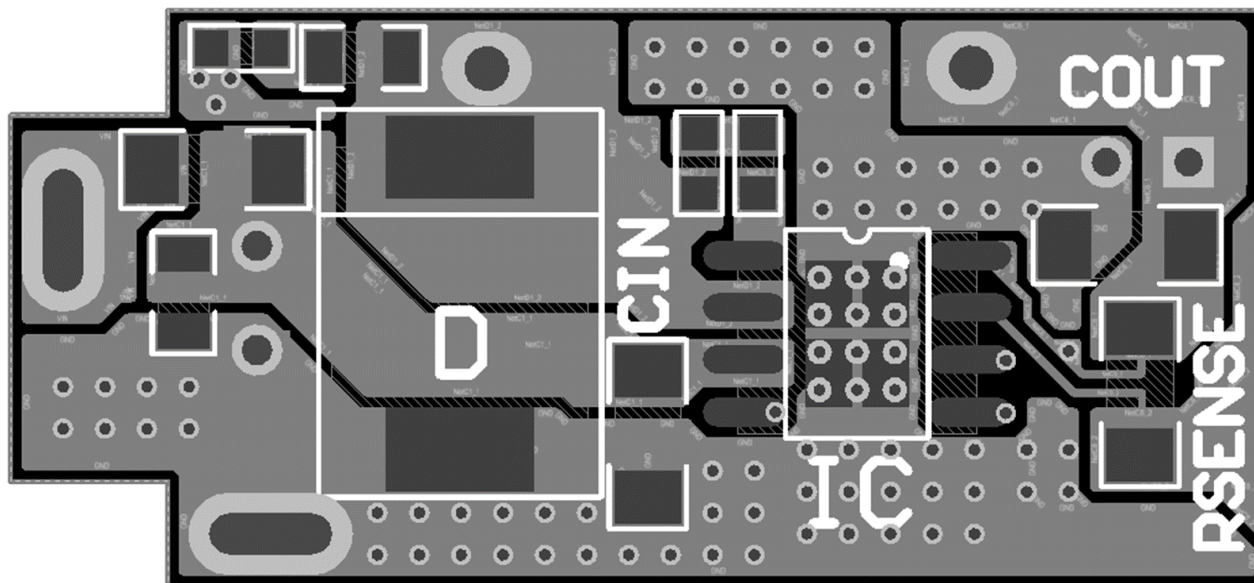

Typical Application Circuit for 5V/3.4A Car Charger

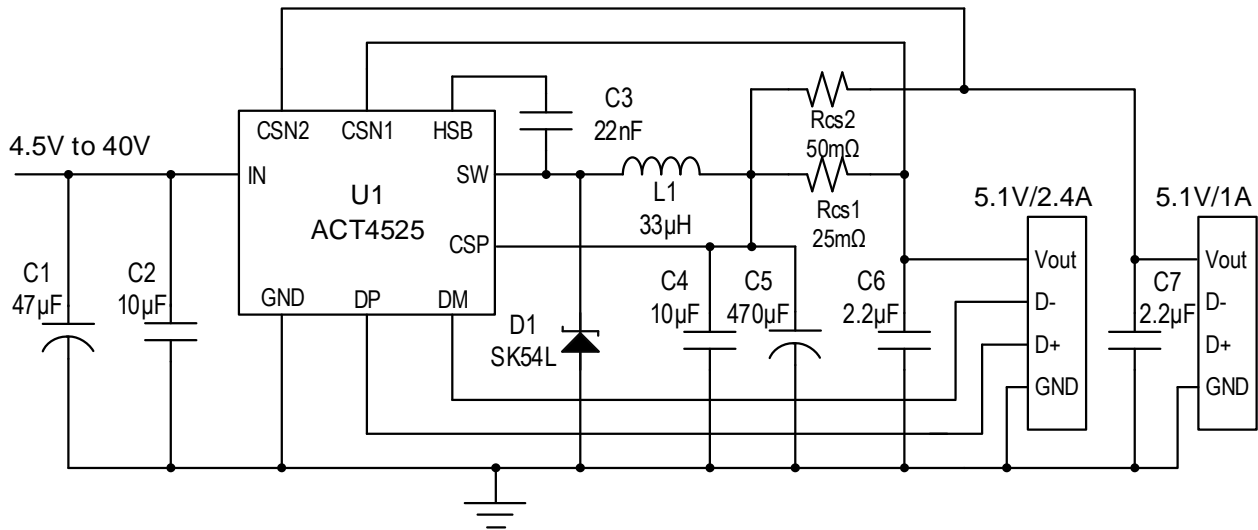

BOM List for 5V/3.4A Car Charger

| ITEM | REFERENCE | DESCRIPTION | MANUFACTURER | QTY |
|------|-----------|--|--------------|-----|
| 1 | U1 | IC, ACT4525, SOP-8EP | Active-Semi | 1 |
| 2 | C1 | Capacitor, Electrolytic, 47µF/35V | Murata, TDK | 1 |
| 3 | C2 | Capacitor, Ceramic, 10µF/25V, 1206, SMD | Murata, TDK | 1 |
| 4 | C3 | Capacitor, Ceramic, 22nF/25V, 0603, SMD | Murata, TDK | 1 |
| 5 | C4 | Capacitor, Ceramic, 10µF/10V, 1206, SMD | Murata, TDK | 1 |
| 6 | C5 | Capacitor, Electrolytic, 470µF/10V | Murata, TDK | 1 |
| 7 | C6,C7 | Capacitor, Ceramic, 2.2µF/10V, 0805, SMD | Murata, TDK | 2 |
| 8 | L1 | Inductor, 33µH, 4.5A, 20%, | | 1 |
| 9 | D1 | Diode, Schottky, 40V/5A, SK54L | Panjit | 1 |
| 10 | Rcs1 | Chip Resistor, 25mΩ, 1206, 1/2W, 1% | SART | 1 |
| 11 | Rcs2 | Chip Resistor, 50mΩ, 1206, 1/2W, 1% | SART | 1 |

TYPICAL PERFORMANCE CHARACTERISTICS

(Schematic as show in typical application circuit, Ta = 25°C, unless otherwise specified)

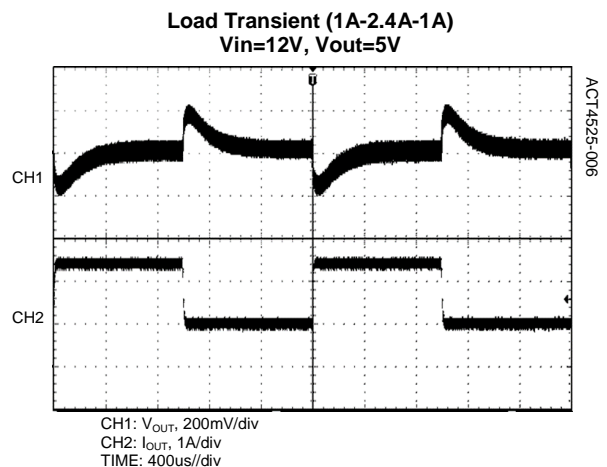
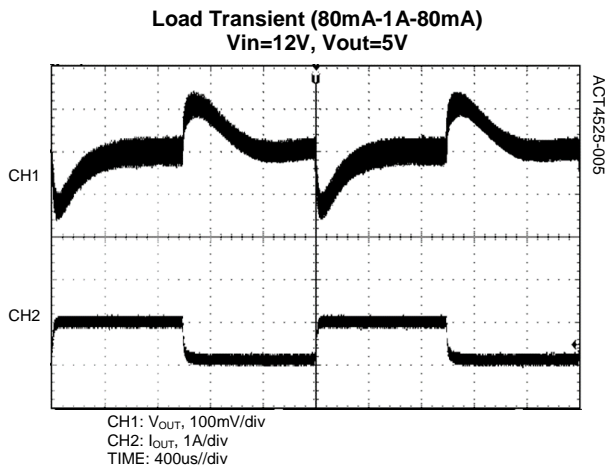
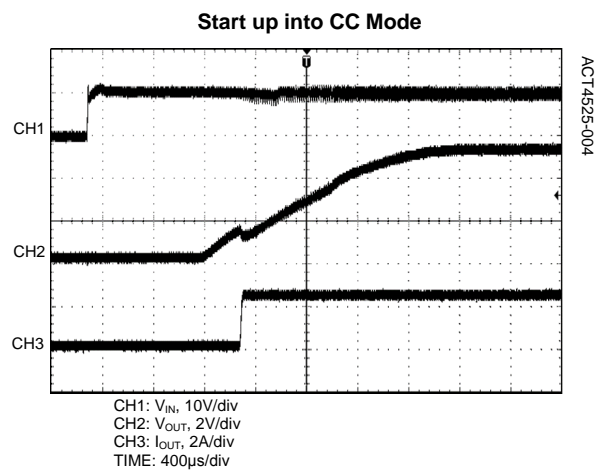
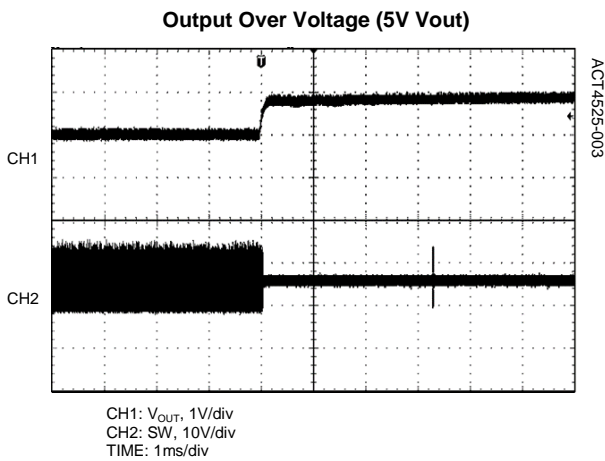
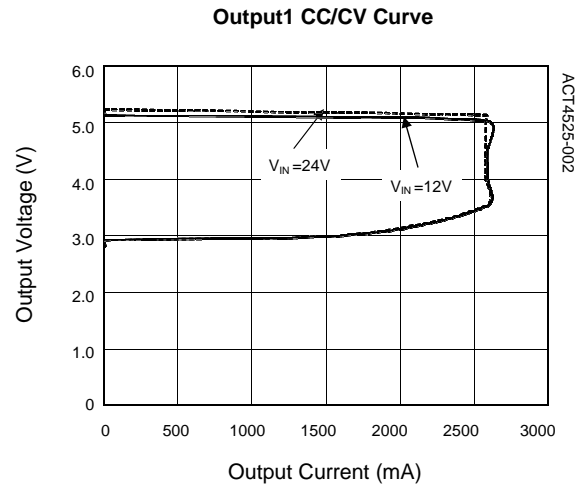
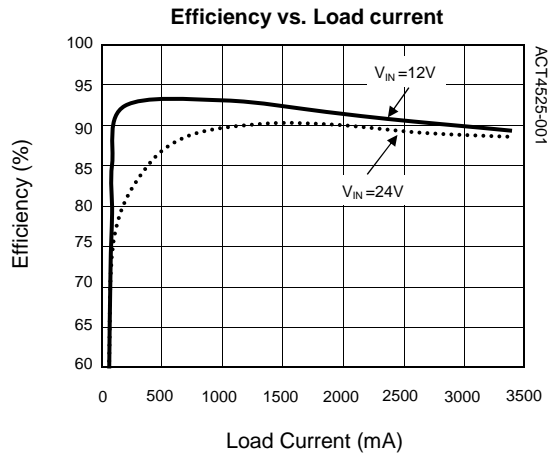

PACKAGE OUTLINE

SOP-8EP PACKAGE OUTLINE AND DIMENSIONS

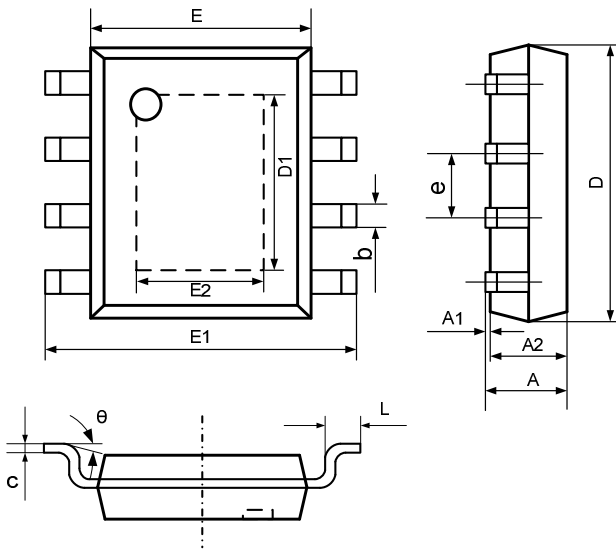

| SYMBOL | DIMENSION IN MILLIMETERS | | DIMENSION IN INCHES | |
|----------|--------------------------|-------|---------------------|-------|
| | MIN | MAX | MIN | MAX |
| A | 1.350 | 1.727 | 0.053 | 0.068 |
| A1 | 0.000 | 0.152 | 0.000 | 0.006 |
| A2 | 1.245 | 1.550 | 0.049 | 0.061 |
| b | 0.330 | 0.510 | 0.013 | 0.020 |
| c | 0.170 | 0.250 | 0.007 | 0.010 |
| D | 4.700 | 5.100 | 0.185 | 0.200 |
| D1 | 3.202 | 3.402 | 0.126 | 0.134 |
| E | 3.734 | 4.000 | 0.147 | 0.157 |
| E1 | 5.800 | 6.200 | 0.228 | 0.244 |
| E2 | 2.313 | 2.513 | 0.091 | 0.099 |
| e | 1.270 TYP | | 0.050 TYP | |
| L | 0.400 | 1.270 | 0.016 | 0.050 |
| θ | 0° | 8° | 0° | 8° |

Active-Semi, Inc. reserves the right to modify the circuitry or specifications without notice. Users should evaluate each product to make sure that it is suitable for their applications. Active-Semi products are not intended or authorized for use as critical components in life-support devices or systems. Active-Semi, Inc. does not assume any liability arising out of the use of any product or circuit described in this datasheet, nor does it convey any patent license.

Active-Semi and its logo are trademarks of Active-Semi, Inc. For more information on this and other products, contact sales@active-semi.com or visit <http://www.active-semi.com>.

 is a registered trademark of Active-Semi.