

Standard Products

ACT4808N Dual Transceivers

for MACAIR (A3818, A4905, A5232, A5690) and MIL-STD-1553A/B

www.aeroflex.com/Avionics

May 25, 2005



FEATURES

- ACT4808N Dual Transceiver meets MIL-STD-1553A & B, Macair A3818, A5690, A5232 and A4905 specs
- *New Low Power Model*
- Operates with $\pm 12V$ to $\pm 15V$ & $+5V$ Power Supplies
- Voltage source output
- Plug-in or Flat Package
- Monolithic construction
- Designed for commercial, industrial and aerospace applications
- MIL-PRF-38534 compliant devices available
- Aeroflex-Plainview is a Class H & K MIL-PRF-38534 manufacturer

GENERAL DESCRIPTION

The Aeroflex-Plainview ACT4808N is a monolithic transceiver design which provides full compliance with Macair (A-3818, A-4905, A-5232 and A-5690) and MIL-STD-1553A/B data bus requirements and can be considered a "Universal" Transceiver.

The dual channel transceiver performs the front-end analog function of inputting and outputting data through a transformer to the MIL-STD-1553 or Macair data bus.

Design of this transceiver reflects particular attention to active filter performance. This results in low bit and word error rate with superior waveform purity and minimal zero crossover distortion. The ACT4808N series active transmit filter design has additional high frequency roll-off to provide the required Macair low harmonic distortion waveform without increasing the pulse delay characteristics significantly.

Efficient transmitter electrical and thermal design provides low internal power dissipation and heat rise at high as well as low duty cycles. The receiver input threshold is set Internally.

TRANSMITTER

The Transmitter section accepts bi-phase TTL data at the input and when coupled to the data bus with a 1:1 transformer the data bus signal produced is 7.0 Volts typical P-P at Point A-A' (See Figure 3 or 4). When both $\overline{\text{DATA}}$ and $\overline{\text{DATA}}$ inputs are held low or high, the transmitter output becomes a high impedance and is "removed" from the line. In addition, an overriding "INHIBIT" input provides for the removal of the transmitter output from the line. A logic "1" signal applied to the "INHIBIT" takes priority over the condition of the data inputs and disables the transmitter (See Transmitter Logic Waveform, Figure 1).

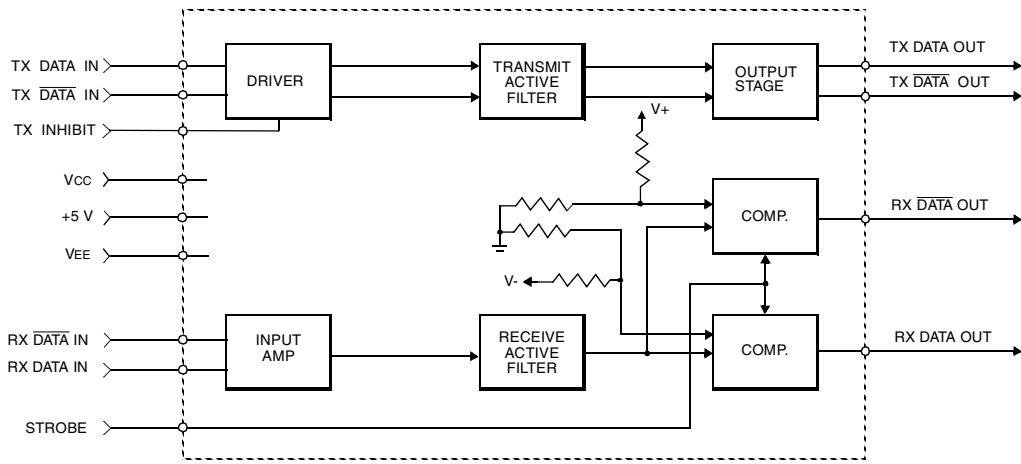
The transmitter utilizes an active filter to suppress harmonics above 1 MHz to meet Macair specifications A-3818, A-4905, A-5232 and A-5690. The transmitter may be safely operated for an indefinite period at 100% duty cycle into a data bus short circuit (Point A-A'). The Transmitter may be safely operated for an indefinite period with the 1553 bus (Point A) short circuited at 100% duty cycle.

RECEIVER

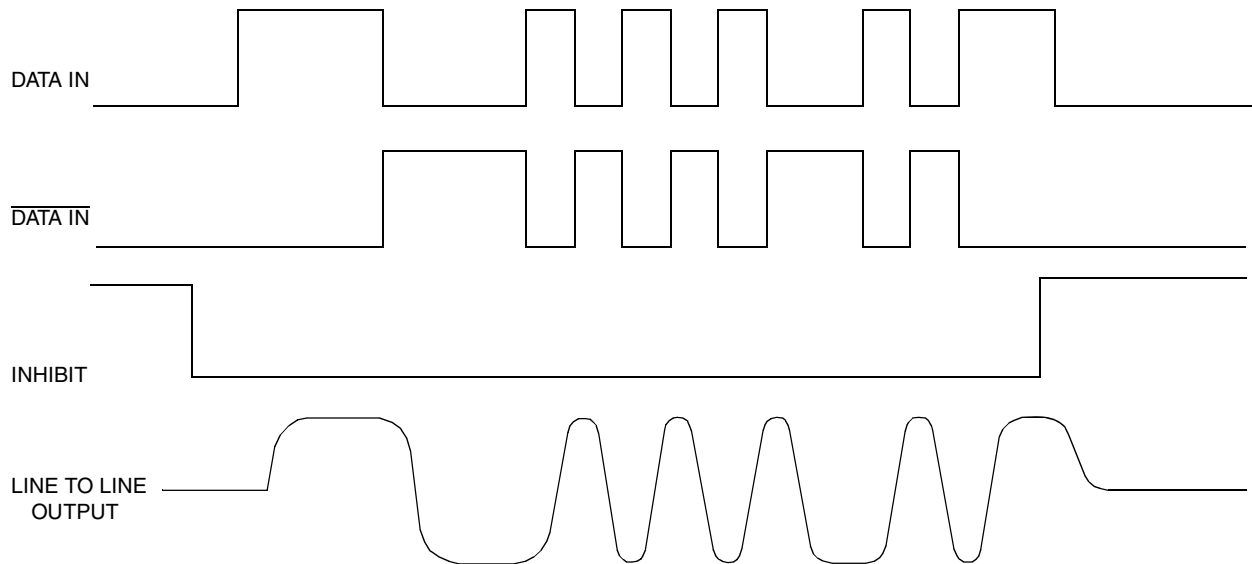
The Receiver section accepts bi-phase differential data at the input and produces two TTL signals at the output. The outputs are $\overline{\text{DATA}}$ and $\overline{\text{DATA}}$, and represent positive and negative excursions of the input beyond a pre-determined threshold (See Receiver Logic Waveform, Figure 2).

The internal threshold is nominally set to detect data bus signals exceeding 1.10 Vp-p and reject signals less than 0.6 Vp-p when used with a 1:1 turns ratio transformer (See Figure 4 for transformer data and typical connection).

A low level at the Strobe input inhibits the $\overline{\text{DATA}}$ and $\overline{\text{DATA}}$ outputs.



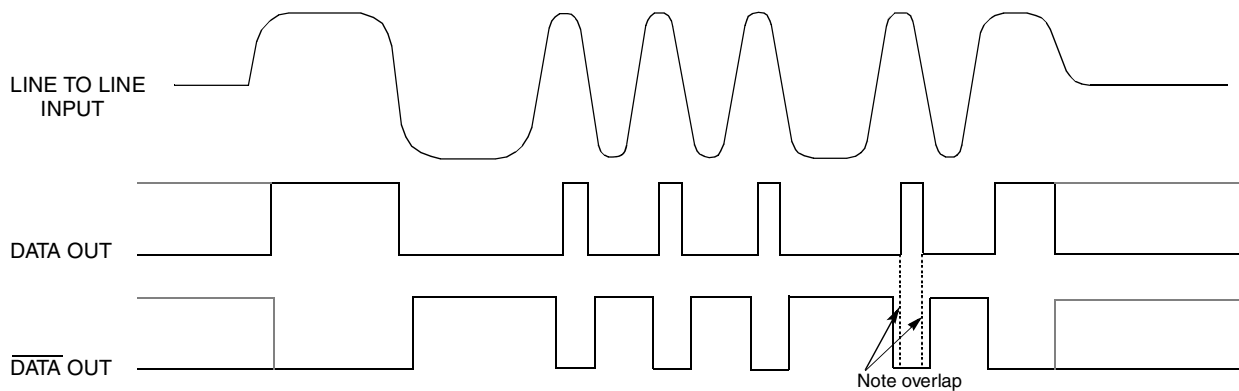
BLOCK DIAGRAM (WITHOUT TRANSFORMER)



NOTES:

1. Line to line waveforms illustrate Macair signals, MIL-STD-1553 signals are trapezoidal.
2. DATA and $\overline{\text{DATA}}$ inputs must be complementary waveforms or 50% duty cycle average, with no delays between them.
3. DATA and $\overline{\text{DATA}}$ must be in the same state during off time (both high or low).

FIGURE 1 – TRANSMITTER LOGIC WAVEFORMS IDEALIZED



NOTE: Waveforms shown are for normally low devices. For normally high receiver output level devices, the receiver outputs are swapped as shown by the dashed lines.

FIGURE 2 – RECEIVER LOGIC WAVEFORMS IDEALIZED

ABSOLUTE MAXIMUM RATINGS

Operating Case Temperature	-55°C to +125°C	
Storage Case Temperature	-65°C to +150°C	
Power Supply Voltages (VCC, VEE, VL)	±12VDC to ±18VDC	+5VDC to +7VDC
Logic Input Voltage	-0.3 VDC to +5.5 VDC	
Receiver Differential Input	±40 VP-P	
Receiver Input Voltage (Common Mode)	±10 V	
Driver Peak Output Current	150 mA	
Total Package Power Dissipation over the Full Operating Case Temperature Range	3.25 Watts (Note: Normal operation conditions require one transmitter on and the other off at any given time)	
Maximum Junction to Case Temperature	16.25°C	
Thermal resistance – Junction to Case	5°C/W	

ELECTRICAL CHARACTERISTICS – DRIVER SECTION 1/ 2/

INPUT CHARACTERISTICS, TX DATA IN or TX $\overline{\text{DATA}}$ IN

Parameter	Condition	Symbol	Min	Typ	Max	Unit
"0" Input Current	V _{IN} = 0.4V	I _{ILD}	-	-0.1	-0.2	mA
"1" Input Current	V _{IN} = 2.7V	I _{IHD}	-	1	40	μA
"0" Input Voltage	-	V _{ILD}	-	-	0.7	V
"1" Input Voltage	-	V _{IHD}	2.0	-	-	V

INHIBIT CHARACTERISTICS

"0" Input Current	V _{IN} = 0.4V	I _{ILI}	-	-0.1	-0.2	mA
"1" Input Current	V _{IN} = 2.7V	I _{IHI}	-	1.0	40	μA
"0" Input Voltage	-	V _{ILI}	-	-	0.7	V
"1" Input Voltage	-	V _{IHI}	2	-	-	V
Delay from TX inhibit, (0→1) to inhibited output	-	t _{DXOFF}	-	350	700	nS
Delay from TX inhibit, (1→0) to active output	-	t _{DXON}	-	300	500	nS
Differential Output Noise, inhibit mode	3/	V _{NOI}	-	0.8	10	mVp-p
Differential Output Impedance *	4/	Z _{OI}	2K	-	-	Ω

* See Aeroflex Application note# 113 for reference.

OUTPUT CHARACTERISTICS

Differential output - Direct coupled stub	Point B- B' Z _O = 70Ω	V _O	26	29	32	V _{p-p}
Differential output - Transformer coupled stub (See Figures 3 and 4)			18	21	25	V _{p-p}
Differential output offset - Direct coupled stub Fig. 4 Differential output offset - Xformer coupled stub Fig. 3	5/	V _{OS}	V _{OS}	-	±360 ±250	mVpk mVpk
Differential output rise / fall times (see Figure 5)	10% - 90%	t _R & t _F	200	250	300	nS
Delay from 50% Point of TX DATA or TX $\overline{\text{DATA}}$ input to zero crossing of differential output.	-	t _{DTX}	-	240	300	nS

ELECTRICAL CHARACTERISTICS – RECEIVER SECTION

Parameter	Condition	Symbol	Min	Typ	Max	Unit
Differential Input Impedance	f = 1MHz	Z _{IN}	10K	-	-	Ω
Differential Input Voltage Range	-	V _{IDR}	-	-	40	V _{p-p}
Input Common Mode Voltage Range	-	V _{ICR}	10	-	-	V _{p-p}
Common Mode Rejection Ratio	-	CMRR	40	-	-	dB

STROBE CHARACTERISTICS (LOGIC "0" INHIBITS OUTPUT)

"0" Input Current	V _S = 0.4 V	I _{IL}	-	-0.2	-0.4	mA
"1" Input Current	V _S = 2.7 V	I _{IH}	-	1.0	+40	μA
"0" Input Voltage	-	V _{IL}	-	-	0.7	V
"1" Input Voltage	-	V _{IH}	2.0	-	-	V
Strobe Delay (Turn-on or Turn-off)	-	t _{SD}	-	40	150	nS

THRESHOLD CHARACTERISTICS (SINEWAVE INPUT)

Internal Threshold Voltage Figure 4	Point B-B' 1MHz	V _{TH}	0.60	0.80	1.10	V _{p-p}
-------------------------------------	--------------------	-----------------	------	------	------	------------------

OUTPUT CHARACTERISTICS, RX DATA AND RX $\overline{\text{DATA}}$

"1" State	I _{OH} = -0.4 mA	V _{OH}	2.5	3.6	-	V
"0" State	I _{OL} = 4 mA	V _{OL}	-	0.35	0.5	V
Receiver Output Skew	6/	t _{RXSK}	-	-	10	nS
Delay (average), from differential input zero crossings to RX DATA and RX $\overline{\text{DATA}}$ output 50% points	7/	t _{DRX}	-	300	450	nS

POWER SUPPLY CURRENTS PER CHANNEL 1/ 2/

V_{CC} = +12V to +15V, V_{EE} = -12V to -15V, V_L = +5V

Duty Cycle	Condition	Symbol	Typ	Max	Unit
Transmitter Standby	Pt. B-B' Z _O = 70 Ω, V _O = 29 VPK-PK Bit Pattern = FFFF _{HEX} Figure 4	I _{CC}	5	10	mA
		I _{EE}	25	35	
		I _L	18	30	
25%		I _{CC}	20	30	
		I _{EE}	40	60	
		I _L	18	30	
50%		I _{CC}	40	60	
		I _{EE}	60	80	
		I _L	18	30	
100%		I _{CC}	85	120	
		I _{EE}	105	140	
		I _L	18	30	

TYPICAL HYBRID POWER DISSIPATION *, PER CHANNEL

Power Supply Conditions	Condition	Standby	100% Duty Cycle	Unit
PSC1 V _{CC} = +15V V _{EE} = -15V V _L = +5V	Point B-B' Z _O = 70 Ω, V _O = 29 V _{PK-PK} Bit Pattern = FFFF _{HEX} Figure 4	0.540	2.167	Watts
PSC2 V _{CC} = +15V V _{EE} = -12V V _L = +5V		0.465	1.852	
PSC3 V _{CC} = +12V V _{EE} = -12V V _L = +5V		0.450	1.600	

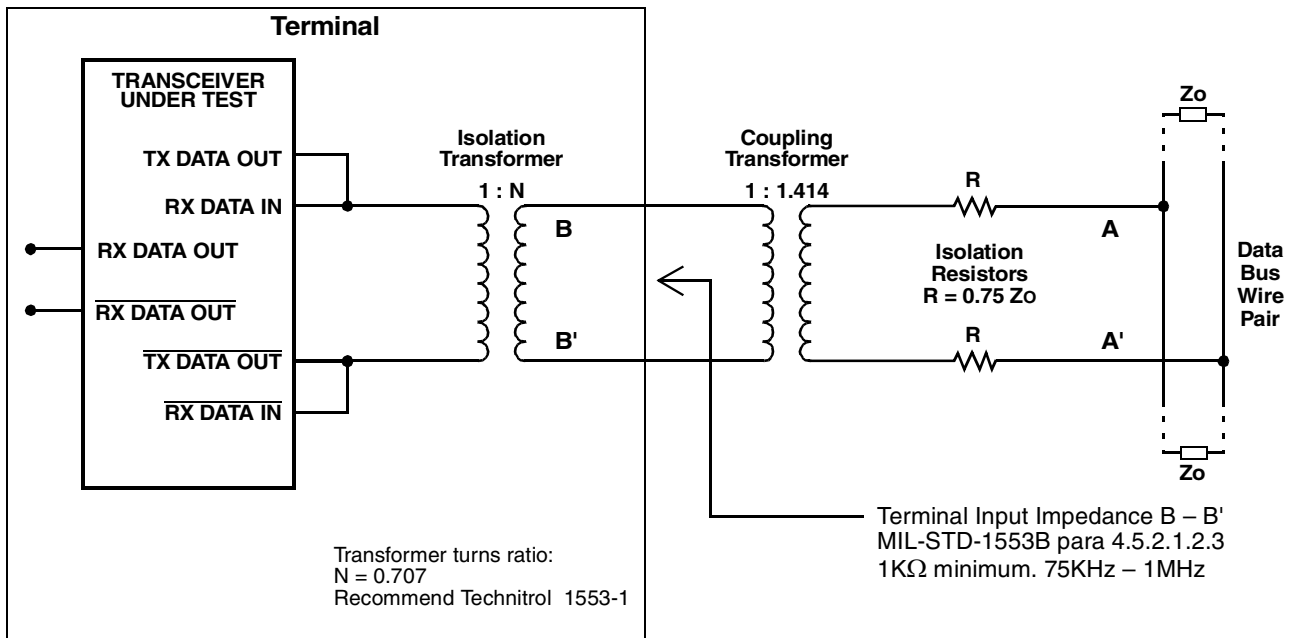
* See Aeroflex Application note# 112 for reference.

RECOMMENDED POWER SUPPLY VOLTAGE RANGE

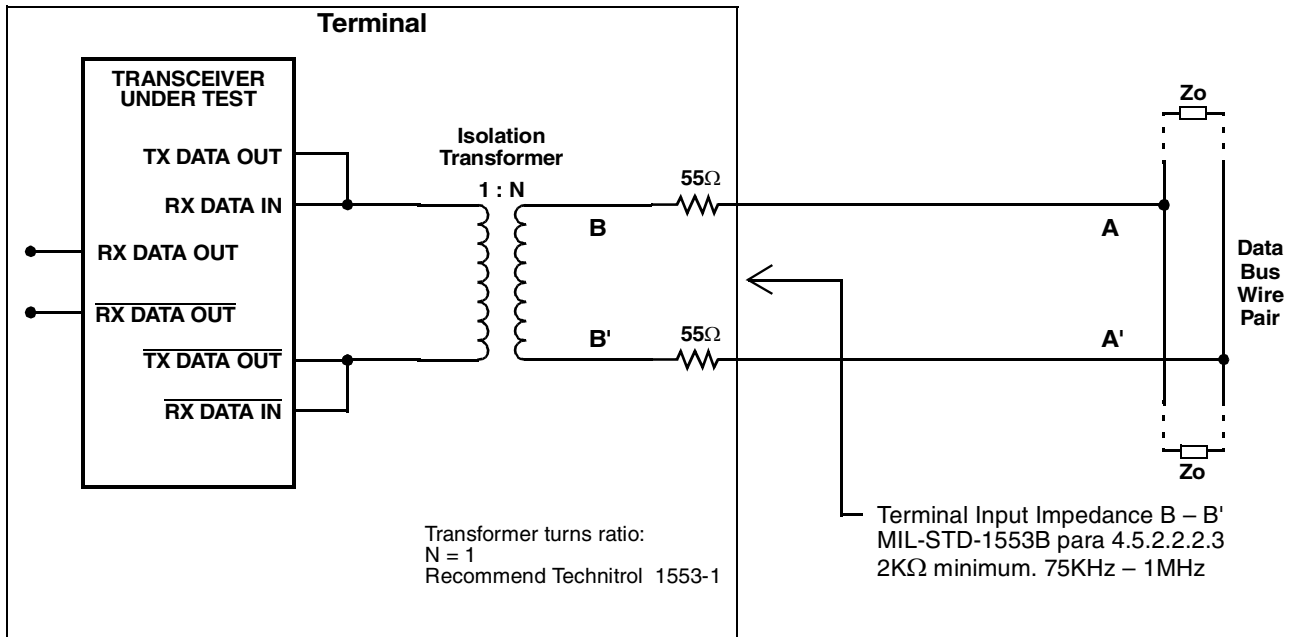
+V	+11.4 Volts to +15.75 Volts
-V	-11.4 Volts to -15.75 Volts
Logic	+4.5 Volts to +5.5 Volts

Notes:

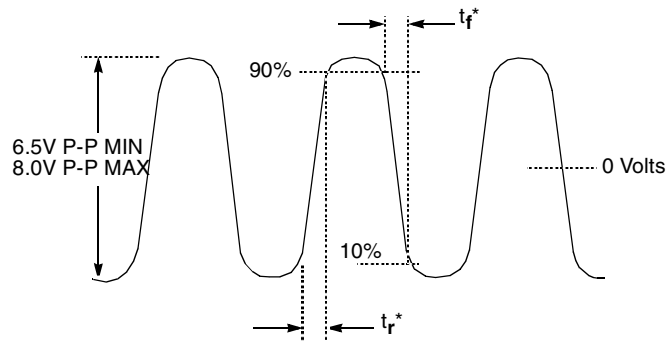
- V_{CC} = +15Volts ±0.75V, V_{EE} = -15Volts ±0.75V, V_{IL} = +5Volts ±0.5V, T_C = -55°C to +125°C, unless otherwise specified.
- All typical values are measured at +25°C.
- Characteristics guaranteed by design, not production tested.
- Power ON/OFF, measured from 75KHz to 1MHz at Point A-A' Figure 4, in accordance with MIL-STD-1553B paragraph 4.5.2.2.2.3.
- At Point A-A' on Figure 3 or 4, 2.5 μS after midpoint crossing of the parity bit of the last word of a 660 μS message.
- Receiver skew is defined as the time from the rising edge of RX DATA OUT to the rising edge of RX $\overline{\text{DATA}}$ OUT minus 500 nS, with a sine wave input of 3 V_{pk-pk} at 1MHz driven into Point B-B' of Figure 4 or 2.1 V_{pk-pk} at 1MHz driven into Point B-B' of Figure 3. The specification maximum is guaranteed for T_A = 25°C only. Standard TTL loads applied to RX DATA Outputs.
- This test is performed while the Transceiver is reading its own transmission. This condition is called "Wraparound". Standard TTL loads applied to RX DATA Outputs.



**FIGURE 3 – DATABUS INTERFACE USING TRANSFORMER COUPLING
(FIGURE 9, MIL-STD-1553B)**

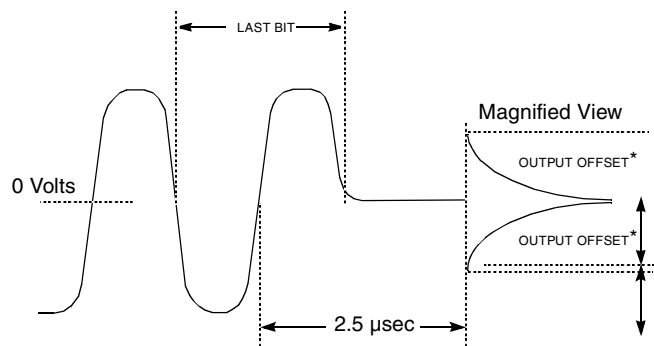


**FIGURE 4 – DATABUS INTERFACE USING DIRECT COUPLING
(FIGURE 10, MIL-STD-1553B)**



* Rise and fall times measured at Point A-A' in Figure 3 or 4

FIGURE 5 – TRANSMITTER (TX) OUTPUT WAVE FORM



*Offset measured at Point A-A' in Figure 3 or 4

FIGURE 6 – TRANSMITTER (TX) OUTPUT OFFSET

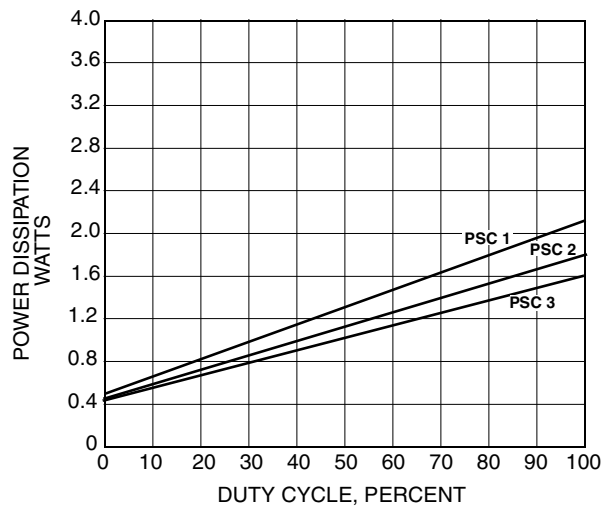
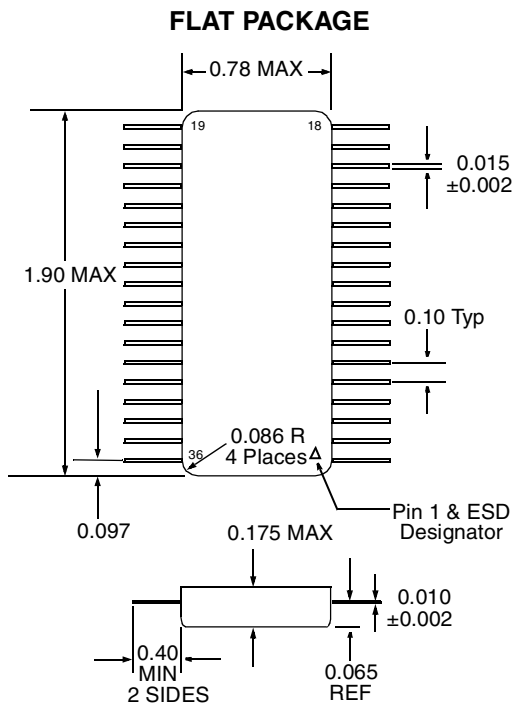
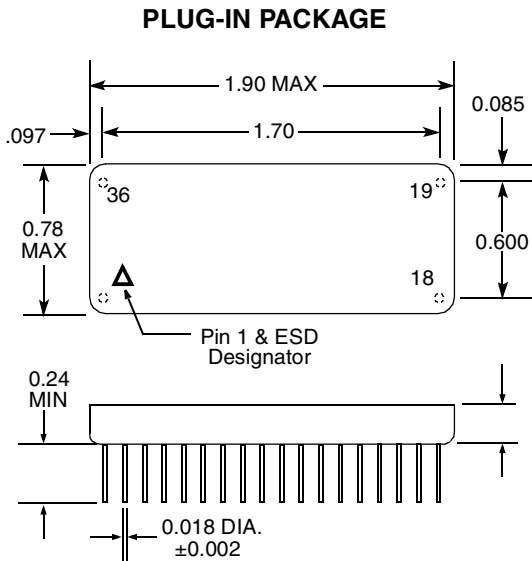


FIGURE 7 – TYPICAL HYBRID POWER DISSIPATION vs. DUTY CYCLE (PER CHANNEL)

PACKAGE CONFIGURATION OUTLINE



- Notes
1. Dimensions shown are in inches
 2. Pins are equally spaced at 0.100 ± 0.002 tolerance, non-cumulative, each row

PACKAGE PINS & FUNCTIONS

Pin #	Function	Channel
1	TX DATA OUT	A
2	TX DATA OUT	A
3	GROUND	A
4	NC	
5	RX DATA OUT	A
6	STROBE	A
7	GROUND	A
8	RX DATA OUT	A
9	CASE	
10	TX DATA OUT	B
11	TX DATA OUT	B
12	GROUND	B
13	NC	
14	RX DATA OUT	B
15	STROBE	B
16	GROUND	B
17	RX DATA OUT	B
18	NC	
19	VCC	B
20	RX DATA IN	B
21	RX DATA IN	B
22	GROUND	B
23	VEE	B
24	+5V	B
25	INHIBIT	B
26	TX DATA IN	B
27	TX DATA IN	B
28	VCC	A
29	RX DATA IN	A
30	RX DATA IN	A
31	GROUND	A
32	VEE	A
33	+5 V	A
34	INHIBIT	A
35	TX DATA IN	A
36	TX DATA IN	A

CONFIGURATIONS AND ORDERING INFORMATION

Model No.	Receiver Data level	DESC SMD	Case	Configuration
ACT4808N-D	Normally Low	Pending	Plug-In Package	Dual
ACT4808N-DF			Flat Package	
ACT4808N-DI	Normally High		Plug-In Package	
ACT4808N-DFI			Flat Package	

PLAINVIEW, NEW YORK
Toll Free: 800-THE-1553
Fax: 516-694-6715

INTERNATIONAL
Tel: 805-778-9229
Fax: 805-778-1980

NORTHEAST
Tel: 603-888-3975
Fax: 603-888-4585

SE AND MID-ATLANTIC
Tel: 321-951-4164
Fax: 321-951-4254

WEST COAST
Tel: 949-362-2260
Fax: 949-362-2266

CENTRAL
Tel: 719-594-8017
Fax: 719-594-8468

www.aeroflex.com info-ams@aeroflex.com



Aeroflex Microelectronic Solutions reserves the right to change at any time without notice the specifications, design, function, or form of its products described herein. All parameters must be validated for each customer's application by engineering. No liability is assumed as a result of use of this product. No patent licenses are implied.



Our passion for performance is defined by three attributes represented by these three icons: solution-minded, performance-driven and customer-focused