

FEATURES

- Adjustable Output Voltage
- Drives OLEDs or White LEDs
- 30V High Voltage Switch
- 1MHz Switching Frequency
- Tiny Inductors and Capacitors
- Tiny SOT23-5 Package

APPLICATIONS

- OLED Applications
- Cell Phones
- Digital Cameras
- PDAs, Laptops
- MP3 Players
- GPS

GENERAL DESCRIPTION

The ACT6311 step-up DC/DC converter is optimized for driving OLEDs or white LEDs. It can provide an output voltage up to 24V. The device is capable of driving up to seven LEDs in series from a Lithium-Ion battery, with inherent current matching and uniform brightness.

The ACT6311 incorporates a 30V high voltage switch. The device operates at 1MHz and allows the use of few external components. The ACT6311 is available in the tiny SOT23-5 package.

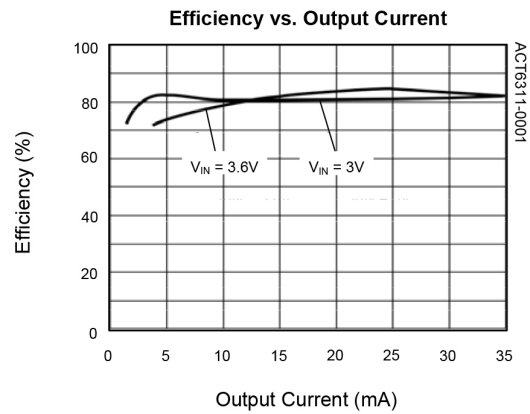
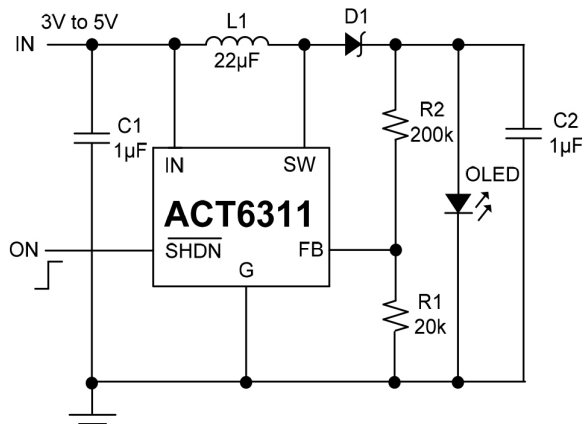

Figure 1. Typical Application Circuit

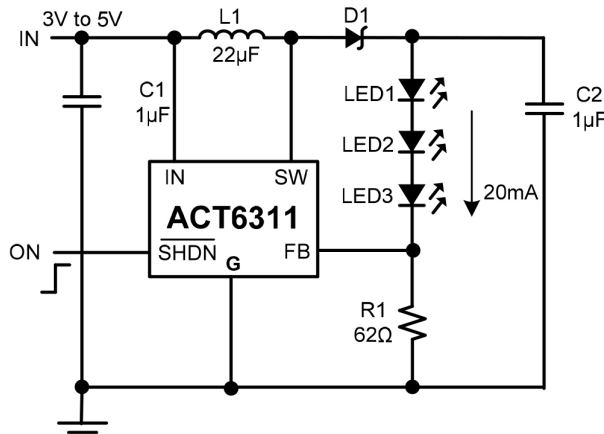
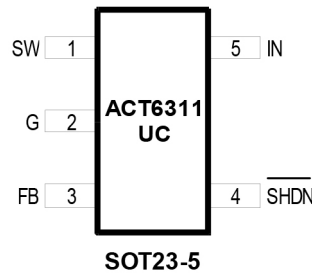

Figure 2: Application as White LED Drive

ORDERING INFORMATION

PART NUMBER	TEMPERATURE RANGE	PACKAGE	PINS	TOP MARK	PACKING
ACT6311UC-T	-40°C to 85°C	SOT23-5	5	YCXB	TAPE & REEL

PIN CONFIGURATION



PIN DESCRIPTION

PIN NUMBER	PIN NAME	PIN DESCRIPTION
1	SW	Switch Output. Connect this pin to the inductor and the Schottky diode. To reduce EMI, minimize the PCB trace path between this pin and the input bypass capacitor.
2	G	Ground.
3	FB	Feedback Input. This pin is referenced to 1.24V
4	SHDN	Shutdown Control. Connect to a logic high to enable the device. Connect to a logic low to disable the device. Never leave the pin unconnected.
5	IN	Supply Input. Bypass to G with a capacitor 1µF capacitor or higher.

ABSOLUTE MAXIMUM RATINGS

(Note: Exceeding these limits may damage the device. Exposure to absolute maximum rating conditions for long periods may affect device reliability.)

PARAMETER	VALUE	UNIT
IN, SHDN Voltage	-0.3 to 6	V
SW Voltage	-0.3 to 30	V
FB Voltage	-0.3 to $V_{IN} + 0.3$	V
Maximum Power Dissipation (derate 5mW/°C above $T_A = 50^\circ\text{C}$)	0.4	W
Junction to Ambient Thermal Resistance (θ_{JA})	190	°C/W
Operating Junction Temperature	-40 to 150	°C
Lead Temperature (Soldering, 10 sec)	300	°C

ELECTRICAL CHARACTERISTICS

($V_{IN} = V_{SHDN} = 3\text{V}$, $T_A = 25^\circ\text{C}$, unless otherwise specified.)

PARAMETER	SYMBOL	TEST CONDITIONS	MIN	TYP	MAX	UNIT
Input Voltage Range			2.5		5.5	V
Feedback Voltage	V_{FB}	$V_{IN} = 3\text{V}$	1.18	1.24	1.30	V
FB Input Current				50		nA
Supply Current		SHDN = IN		0.7	1.5	mA
Supply Current in Shutdown		SHDN = G		0	1	μA
Switching Frequency	f_{SW}		0.8	1	1.2	MHz
Maximum Duty Cycle	D_{MAX}		80	85		%
Switch Current Limit	I_{LIM}	75% Duty Cycle		320		mA
Switch On Voltage		$I_{SW} = 200\text{mA}$		350		mV
Switch Leakage Current		$V_{SW} = 20\text{V}$, SHDN = G			10	μA
SHDN Logic High Threshold			1.6			V
SHDN Logic Low Threshold					0.4	V
SHDN Input Current				0	1	μA

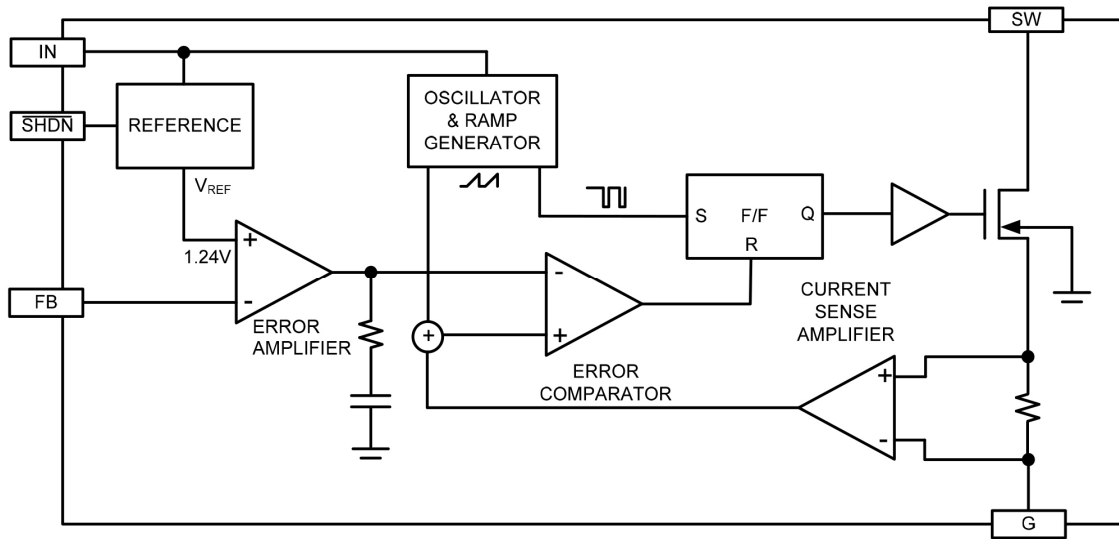

Figure 3. Functional Block Diagram

FUNCTIONAL DESCRIPTION

The ACT6311 is a high efficiency step-up DC/DC converter that employs a current-mode, fixed frequency pulse-width modulation (PWM) architecture with excellent line and load regulation. Figure 3 shows the functional block diagram of the IC. The flip-flop is set at the start of each oscillator cycle, and turns on the power switch. During this on time, the switch current level is sensed and added to a ramp signal, and the resulting sum is compared with the output of the error amplifier. If the error comparator

output is high, the flip-flop is reset and the power switch turns off. Thus, the peak inductor current level is controlled by the error amplifier output, which is integrated from the difference between FB input and the 1.24V reference point.

The ACT6311 operates at a constant switching frequency for output current higher than 4mA. If the output current decreases further, the IC will enter frequency modulation mode, resulting in some low frequency ripple.

APPLICATION INFORMATION

Inductor Selection

Table 1:
Recommended Inductors

PART NUMBER	CURRENT RATING (MA)	DCR (Ω)	SUPPLIER
CDRH3D16-220	350	0.5	Sumida
ELJPC220KF	160	4.0	Panasonic
LQH3C220	250	0.7	Murata
LEM2520-220	125	5.5	Taiyo Yuden

A 22μH inductor is typically used for the ACT6311. The inductor should have low DC resistance (DCR) and losses at 1MHz. See Table 1 for examples of small size inductors.

Capacitor Selection

The ACT6311 only requires a 1μF input capacitor and a 1μF output capacitor for most applications. Ceramic capacitors are ideal for these applications. For best performance, use X5R and X7R type ceramic capacitors, which possess less degradation in capacitance over voltage and temperature ranges.

Diode Selection

The ACT6311 requires a fast recovery Schottky diode as the rectifier. Select a low forward voltage drop Schottky diode with a forward current (IF) rating of 100mA to 200mA and a sufficient peak repetitive reverse voltage (VRRM). Some suitable Schottky diodes are listed in Table 2.

Table 2:
Recommended Schottky Diodes

PART NUMBER	IF(MA)	VRRM (V)	SUPPLIER
CMDSH-3	100	30	Central
CMDSH2-3	200	30	Central
BAT54	200	30	Zetex

OLED Application

Figure 1 shows the feedback network necessary to set the output voltage. Select the proper ratio of the two feedback resistors R1 and R2 based on the desired output voltage. Typically choose R1 = 20kΩ and determine R2 from the output voltage:

$$R2 = R1 \left(\frac{V_{OUT}}{1.24V} - 1 \right) \quad (1)$$

White LED Application

The LED current is determined by the value of the feedback resistor R1. Because the FB input of the IC is regulated to 1.24V, the LED current is determined by $I_{LED} = 1.24V/R1$. The value of R1 for different LED currents is shown in Table 3.

Table 3:
R1 Resistor Value Selection

I_{LED} (MA)	R1 (Ω)
5	246
10	124
12	103.3
15	82.7
20	62

To improve efficiency, resistors R2 and R3 can be connected as shown in Figure 4 to lower the effective feedback voltage.

The following are dimming control methods for the ACT6311 series white LED application.

1) PWM Signal Driving SHDN

When a PWM signal is connected to the SHDN pin, the ACT6311 is turned on and off alternately under the control of the PWM signal. The current through the LEDs is either zero or full scale. By changing the duty cycle of the PWM signal (typically 1kHz to 10kHz), a controlled average current is obtained.

2) DC Voltage Control

Figure 5 shows an application in which a DC voltage is used to adjust the LED current. The LED current increases when V_{DC} is lower than V_{FB} and decreases when V_{DC} is higher than V_{FB} . In Figure 5, the LED current range of 15mA to 0mA is controlled by $V_{DC} = 0V$ to 2V.

3) Filtered PWM Control

Figure 6 shows an application using a filtered PWM signal to control dimming.

4) Logic Control

A logic signal can be used to adjust the LED current in a discrete step, as shown in Figure 7.

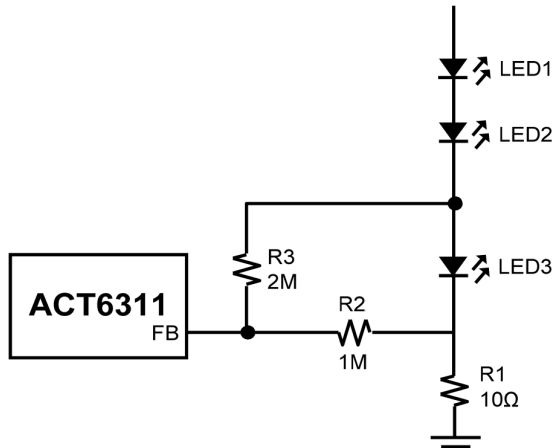

Figure 4. Current Setting for White LED Application

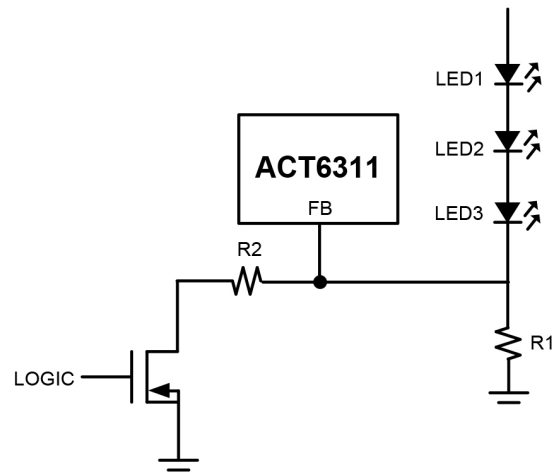

Figure 7. Logic Controlled Dimming

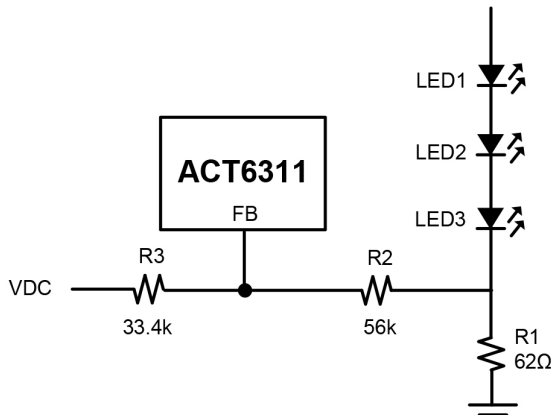

Figure 5. DC Voltage Controlled Dimming

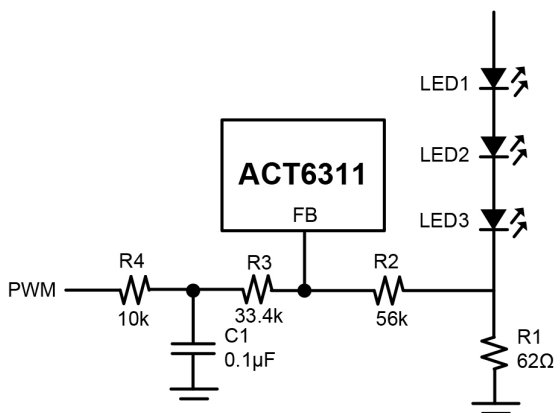

Figure 6. Filtered PWM Controlled Dimming

Start-up and Inrush Current

In order to facilitate quick startup, a soft-start circuit is not incorporated into the ACT6311. When the IC is first turned on with no external soft-start circuit, the peak inrush current is about 400mA. Figure 8 shows an implementation for soft-start. When soft-start and dimming controls are used simultaneously, a low frequency PWM signal (less than 10kHz) or the methods in Figures 5, 6 and 7 should be used.

Open-Circuit Protection (White LEDs)

If one of the LEDs is disconnected, the FB voltage drops to zero and the IC switches at maximum duty cycle. This results in a high voltage that may exceed the SW voltage rating. To limit this voltage, use a Zener diode as shown in Figure 9. The Zener voltage must be large than the total forward voltage of the LEDs and the current rating should be higher than 0.1mA.

Board Layout

To reduce EMI, minimize the area and path length of all traces connected to SW. Use a ground plane under the switching regulator and connect R1 directly to the G pin of the IC.

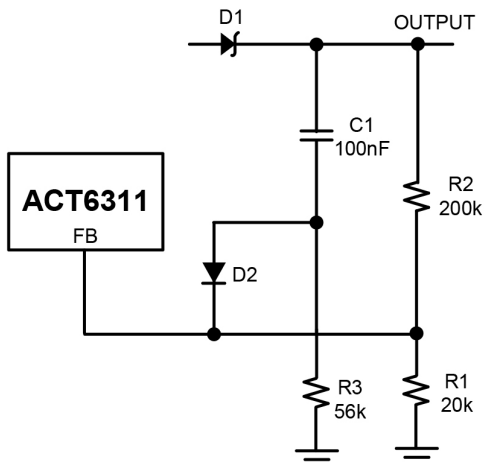

Figure 8: Soft-Start Circuit

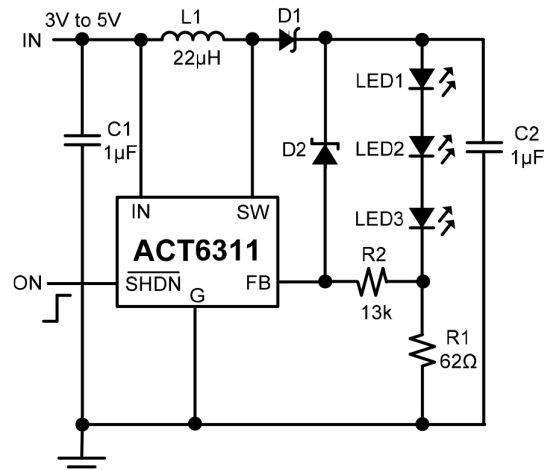
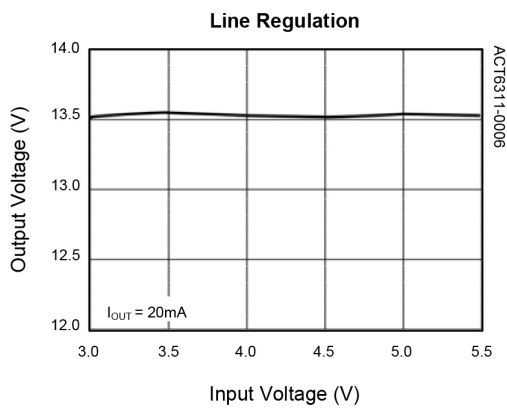
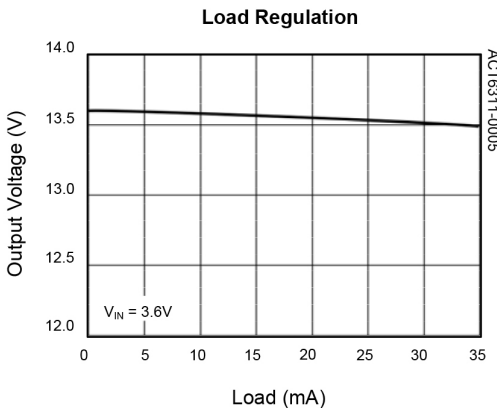
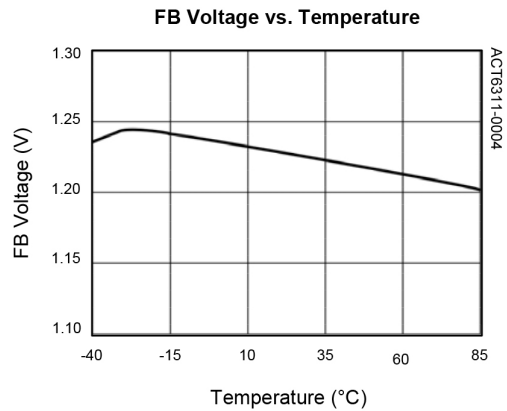
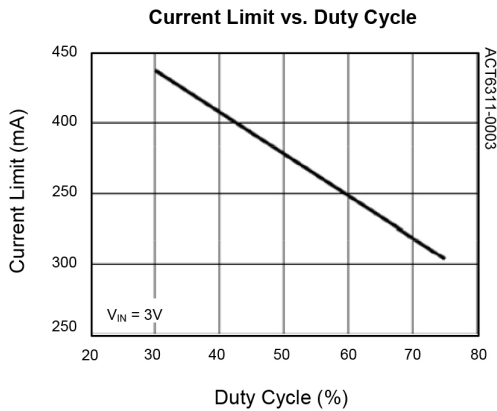
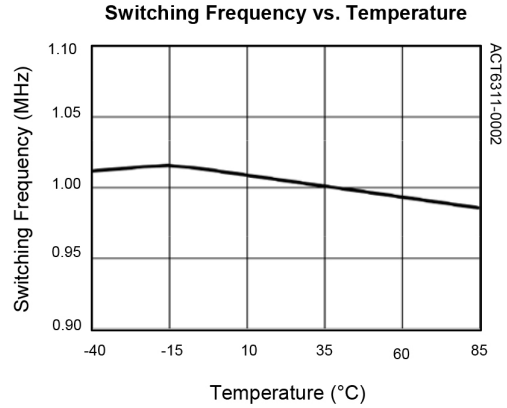
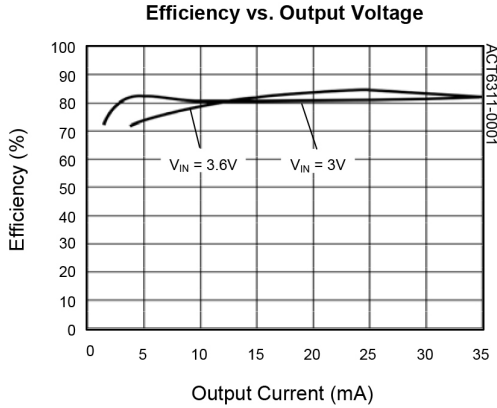

Figure 9: Open-Circuit Protection

TYPICAL PERFORMANCE CHARACTERISTICS

(Circuit of Figure 1, unless otherwise specified.)



TYPICAL PERFORMANCE CHARACTERISTICS CONT'D

(Circuit of Figure 1, unless otherwise specified.)

Switching Waveform in Discontinuous Mode

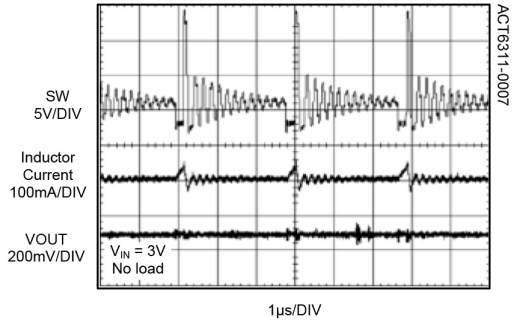

Startup without Soft Start Circuit

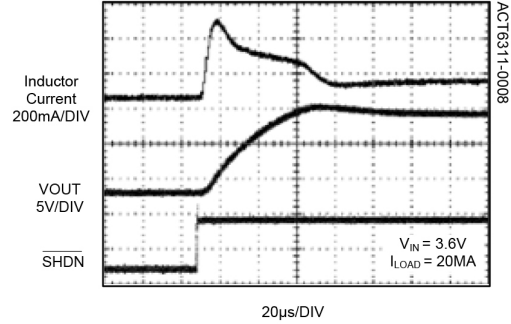

Startup with Soft Start Circuit

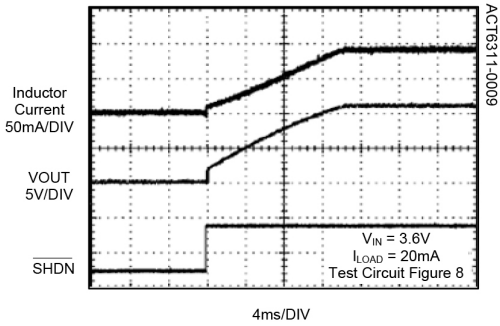

Load Step Response

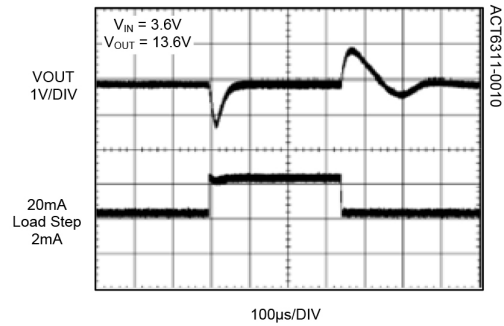

Line Step Response

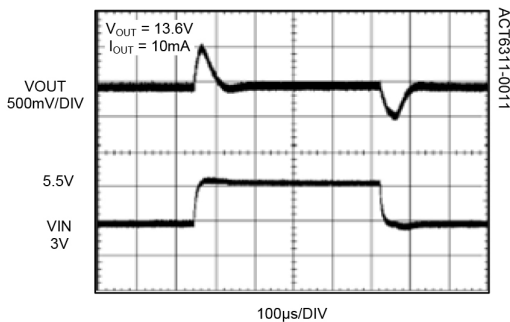

PACKAGE OUTLINE AND DIMENSIONS

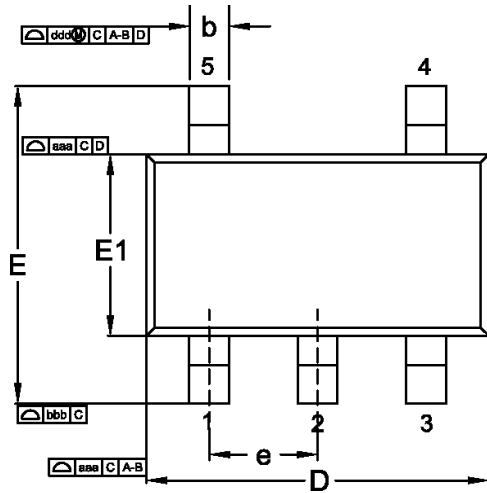

Top View

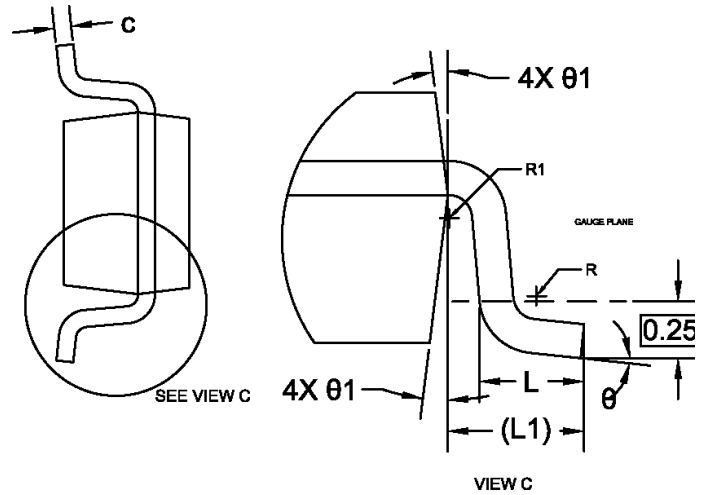

Side View

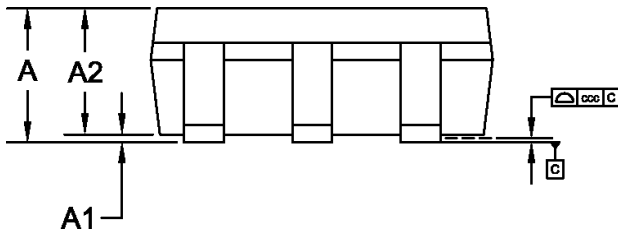

Side View

Dimensional Ref.			
REF.	Min.	Nom.	Max.
A	1.050	--	1.250
A1	0.000	--	0.010
A2	1.050	--	1.150
b	0.300	--	0.500
c	0.100	--	0.200
D	3.000BSC		
E	2.800BSC		
E1	1.600BSC		
e	0.950 BSC		
L	0.300	--	0.600
L1	0.600REF.		
R	0.070	--	--
R1	0.070	--	--
θ	0°	--	8°
θ1	5°	--	15°
Tol. of Form&Position			
aaa	0.15		
bbb	0.20		
ccc	0.10		
ddd	0.25		

Notes

1. ALL DIMENSIONS AND TOLERANCES CONFORM TO ASME Y14.5-2009.
2. ALL DIMENSIONS ARE IN MILLIMETERS.

Product Compliance

This part complies with RoHS directive 2011/65/EU as amended by (EU) 2015/863.

This part also has the following attributes:

- Lead Free
- Halogen Free (Chlorine, Bromine)



Contact Information

For the latest specifications, additional product information, worldwide sales and distribution locations:

Web: www.qorvo.com

Tel: 1-844-890-8163

Email: customer.support@qorvo.com

For technical questions and application information:

Email: appsupport@qorvo.com

Important Notice

The information contained herein is believed to be reliable; however, Qorvo makes no warranties regarding the information contained herein and assumes no responsibility or liability whatsoever for the use of the information contained herein. All information contained herein is subject to change without notice. Customers should obtain and verify the latest relevant information before placing orders for Qorvo products. The information contained herein or any use of such information does not grant, explicitly or implicitly, to any party any patent rights, licenses, or any other intellectual property rights, whether with regard to such information itself or anything described by such information. **THIS INFORMATION DOES NOT CONSTITUTE A WARRANTY WITH RESPECT TO THE PRODUCTS DESCRIBED HEREIN, AND QORVO HEREBY DISCLAIMS ANY AND ALL WARRANTIES WITH RESPECT TO SUCH PRODUCTS WHETHER EXPRESS OR IMPLIED BY LAW, COURSE OF DEALING, COURSE OF PERFORMANCE, USAGE OF TRADE OR OTHERWISE, INCLUDING THE IMPLIED WARRANTIES OF MERCHANTABILITY AND FITNESS FOR A PARTICULAR PURPOSE.**

Without limiting the generality of the foregoing, Qorvo products are not warranted or authorized for use as critical components in medical, life-saving, or life-sustaining applications, or other applications where a failure would reasonably be expected to cause severe personal injury or death.

Copyright 2019 © Qorvo, Inc. | Qorvo® and Active-Semi® are trademarks of Qorvo, Inc.