

### FEATURES

- Multiple Patents Pending
- Up to 95% High Efficiency
- Up to 1.5A Guaranteed Output Current (ACT8311)
- 1.35MHz Constant Frequency Operation
- Internal Synchronous Rectifier Eliminates Schottky Diode
- ACT8310: Up to 1.2A
- ACT8311: Up to 1.5A
- 100% Duty Cycle Low-Dropout Operation
- 0.1 $\mu$ A Shutdown Current
- Small TDFN33-8 Package
  - RoHS-Compliant
- Enable/Disable Control
- Minimal External Components

### APPLICATIONS

- Wireless Handhelds
- Portable Devices
- GPS/PND equipment

### SYSTEM BLOCK DIAGRAM

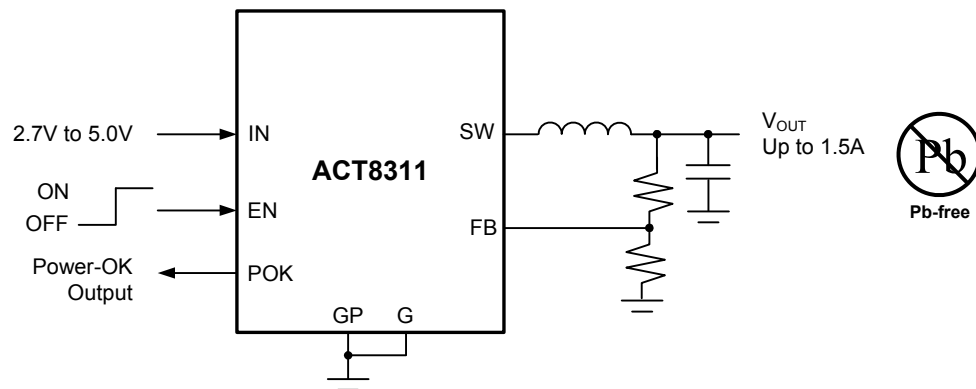

### GENERAL DESCRIPTION

The patent-pending ACT8310/ACT8311 are current-mode, fixed-frequency PWM, synchronous step-down DC/DC converters that are capable of delivering 1.5A with efficiency of up to 95%. These devices operate with a fixed frequency of 1.35MHz, minimizing noise in sensitive equipment as well as optimizing both efficiency and component size and cost.

These devices feature very low-resistance power MOSFET and 100% duty cycle operation, making them ideal choices for portable applications requiring a 3.0V or 3.3V rail to be generated from a Li+ battery.

The ACT8311 is capable of supplying up to 1.5A of output current, while the ACT8310 is capable of supplying up to 1.2A, respectively. All three devices have adjustable output voltages that are programmable down to 1.2V. Contact Qorvo for custom fixed output voltage availability.

## ORDERING INFORMATION

PART NUMBER	OUTPUT CURRENT	OUTPUT VOLTAGE	PACKAGE	PINS	TEMPERATURE RANGE
ACT8310NHADJ-T	1.2A	Adjustable	TDFN33-8	8	-40°C to +85°C
ACT8311NHADJ-T	1.5A	Adjustable	TDFN33-8	8	-40°C to +85°C

## PIN CONFIGURATION

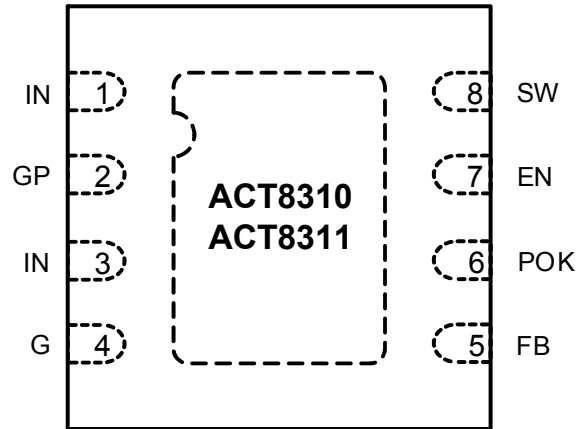

**TDFN33-8**

## PIN DESCRIPTIONS

PIN NUMBER	NAME	DESCRIPTION
1,3	IN	Power Input. Bypass to GP close to IC with a high quality ceramic capacitor.
2	GP	Power Ground. Connect to G with a short trace.
4	G	Analog Ground. Connect to GP with a short trace.
5	FB	Feedback Node. For fixed output voltage versions, connect this pin directly to the output. For the adjustable output versions the voltage at this pin is regulated to 0.8V, connect to this pin to the center of the output feedback resistor divider for voltage setting.
6	POK	Open-Drain Power-OK Status Output. POK is an open-drain output which sinks current when the output voltage is less than 95% of the normal value. When the IC is disabled, POK is high impedance.
7	EN	Enable Input. When higher than 1.4V, this pin turns the IC on. When lower than 0.4V, this pin turn the IC off.
8	SW	Switch Output. Connect this pin to the switching end of the inductor.

## ABSOLUTE MAXIMUM RATINGS<sup>①</sup>

PARAMETER	VALUE	UNIT
IN, SW to GP	-0.3 to +6	V
FB, EN, POK to G	-0.3 to +6	V
FB, EN, SW Voltage	-0.3 to ( $V_{IN} + 0.3, <6$ )	V
GP to G	-0.3 to +0.3	V
Continuous SW Current	Internally limited	A
Junction to Ambient Thermal Resistance ( $\theta_{JA}$ )	61	°C/W
Maximum Power Dissipation (derate 5.3mW/°C above $T_A = 50^\circ\text{C}$ )	1.63	W
Operating Junction Temperature	-40 to 150	°C
Storage Temperature	-55 to 150	°C
Lead Temperature (Soldering, 10 sec)	300	°C

①: Do not exceed these limits to prevent damage to the device. Exposure to absolute maximum rating conditions for long periods may affect device reliability.

## ELECTRICAL CHARACTERISTICS

( $V_{IN} = V_{EN} = 3.6V$ ,  $T_A = 25^\circ C$ , unless otherwise specified.)

PARAMETER	SYMBOL	TEST CONDITIONS	MIN	TYP	MAX	UNIT
Input Voltage Range	$V_{IN}$		2.7		5	V
Under Voltage Lockout Threshold	$V_{UVLO}$	$V_{IN}$ rising, hysteresis = 80mV	2.35	2.5	2.6	V
Standby Supply Current		$V_{FB} = 103\%V_{FB,TYP}$ , $I_{OUT} = 0$		150	310	$\mu A$
Shutdown Supply Current		EN = G, $V_{IN} = 4.2V$		0.1	1	$\mu A$
FB Voltage	$V_{FB}$	$T_A = 25^\circ C$	0.786	0.80	0.814	V
		$-40^\circ C < T_A < 85^\circ C$	0.776	0.80	0.824	
Output Voltage Accuracy		$T_A = 25^\circ C$	-2%	$V_{NOM}$	+2%	V
		$-40^\circ C < T_A < 85^\circ C$	-3%	$V_{NOM}$	+3%	
Output Voltage Line Regulation				0.06	0.4	%/V
Output Voltage Load Regulation				0.6		%
Current Limit		ACT8310NH	1.4	1.7	2.2	A
		ACT8311NH	1.75	2.1	2.8	
Max Output Current (Note 1)		ACT8310NH	1.2			A
		ACT8311NH	1.5			
Oscillator Frequency	$f_{sw}$	$V_{OUT} = 80\%$ of $V_{OUT,NOM}$	1.05	1.35	1.6	MHz
		$V_{FB} = 0.1V$		450		kHz
PMOS On-Resistance	$R_{ONP}$	ACT8310, $I_{SW} = -100mA$		0.12	0.192	$\Omega$
		ACT8311, $I_{SW} = -100mA$		0.10	0.165	
NMOS On-Resistance	$R_{ONN}$	$I_{SW} = 100mA$		0.15	0.26	$\Omega$
EN Logic High Threshold	$V_{IH}$	$V_{IN} = 2.7V$ to $5.0V$	1.4			V
EN Logic Low Threshold	$V_{IL}$	$V_{IN} = 2.7V$ to $5.0V$			0.4	V
EN Input Bias Current	$I_{EN}$	$V_{IN} = 5.0V$ , EN = G or IN		0.01	0.1	$\mu A$
POK Threshold		% of $V_{OUT,NOM}$		95		%
POK Output Low Voltage	$V_{OL}$	$I_{POK} = 100\mu A$		0.008	0.012	V
POK Leakage Current	$I_{POK}$	$V_{POK} = 5.0V$		0.01	0.1	$\mu A$

Note 1: Minimum required load current is 100mA

Figure 1:  
Functional Block Diagram

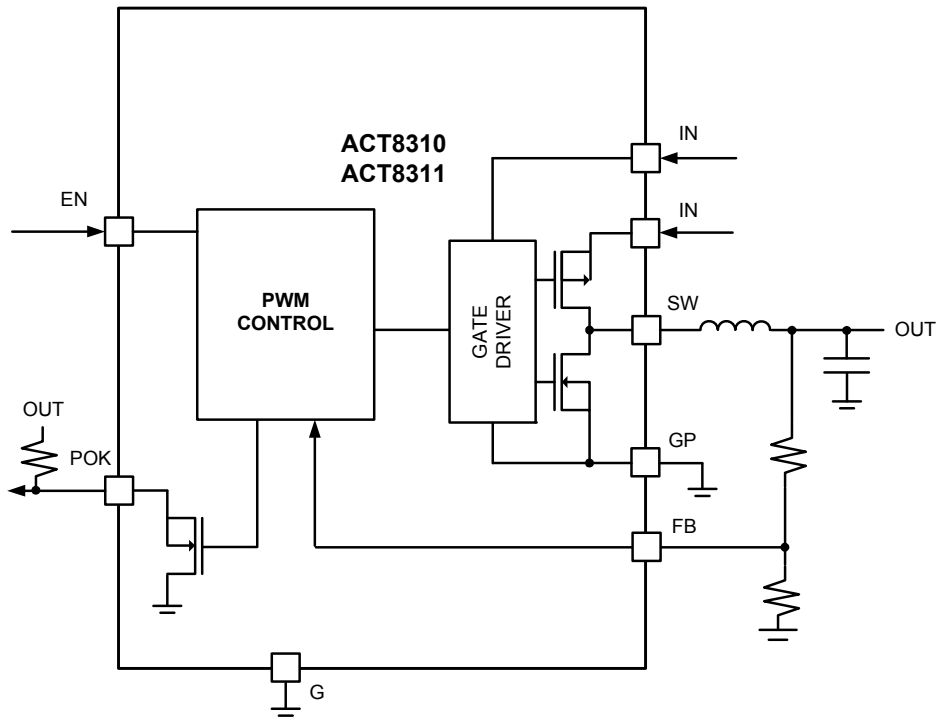
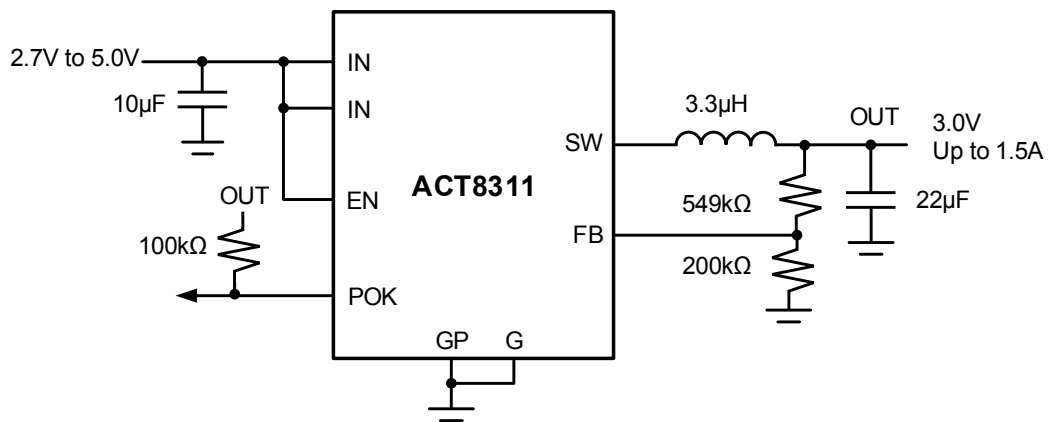

Figure 2:  
Typical Application Circuit



## FUNCTIONAL DESCRIPTION

The patent-pending ACT8310/ACT8311 are current-mode, fixed-frequency PWM, synchronous step-down DC/DC converters that are capable of delivering up to 1.5A (ACT8311) with efficiency of up to 95%. These devices feature very low-resistance power MOSFETs and 100% duty cycle operation, making them ideal choices for portable applications requiring a 3.0V or 3.3V rail to be generated from a Li+ battery. These devices operate with a fixed frequency of 1.35MHz, minimizing noise in sensitive equipment as well as optimizing both efficiency and component size and cost.

### 100% Duty Cycle Operation

These devices are capable of operating at up to 100% duty cycle operation. During 100% duty cycle operation, the high-side power MOSFET is held on continuously, providing a direct connection from the input to the output (through the inductor), ensuring the lowest possible dropout voltage in battery-powered applications.

### Synchronous Rectification

The ACT8310/ACT8311 each feature integrated n-channel synchronous rectifiers, maximizing efficiency and minimizing the total solution size and cost by eliminating the need for external rectifiers.

### Soft-Start

The ACT8310/ACT8311 each include integrated soft-start circuitry. When enabled, the output voltage track an internal 200µs soft-start ramp so that the output power up in a controlled, monotonic manner that is independent of loading.

### Compensation

The ACT8310/ACT8311 each utilize current-mode control and a proprietary internal compensation scheme to simultaneously simplify external component selection and optimize transient performance over their full operating range. No compensation design is required, simply follow a few simple guidelines described below when choosing external components.

### Capacitor Selection

The input capacitor reduces peak currents and noise induced upon the voltage source. A 10µF ceramic capacitor is recommended for most applications.

For most applications, a 22µF ceramic output capacitor is recommended. Although these regulators were designed to take advantage of the benefits of ceramic capacitors, namely small size and very-low ESR,

low-ESR tantalum capacitors can provide acceptable results as well.

### Inductor Selection

These devices were optimized for operation with 3.3µH inductors, although inductors in the 1.5µH to 4.7µH range may be used. Choose an inductor with a low DC-resistance, and avoid inductor saturation by choosing inductors with DC ratings that exceed the maximum output current of the application by at least 30%.

### Output Voltage Setting

Figure 3 shows the feedback network necessary to set the output voltage when using adjustable output voltage options. Select components as follows: Set  $R_{FB2} = 200k\Omega$ , calculate  $R_{FB1}$  using the following equation:

$$R_{FB1} = R_{FB2} \left( \frac{V_{OUT}}{V_{FB}} - 1 \right) \quad (1)$$

Where  $V_{FB}$  is 0.8V.

**Figure 3:**  
**Output Voltage Setting**

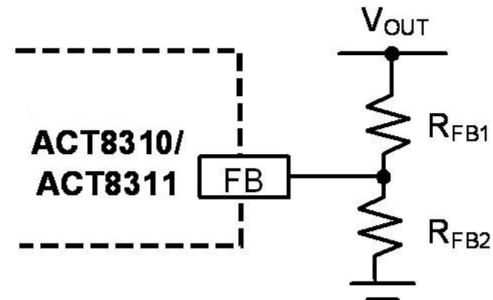

### Enable/Disable Control

These devices may be enabled and disabled using the EN input. Drive EN to a logic-high to enable the regulator, drive EN to a logic-low to disable the regulator. When disabled, each regulator's quiescent supply current drops to less than 1µA.

### Power-OK Output (POK)

These devices feature an open-drain "Power-OK" indicator output. This output sinks current whenever the output voltage is (typically) 5% below the regulation voltage, and goes high-impedance when the output voltage is above this threshold. To generate a logic-level "Power-OK" signal, simply connect a pull-up resistor from POK to an appropriate output voltage.

### PCB Layout Considerations

High switching frequencies and large peak current make PC board layout an important part of step-down DC/DC converter design. A good design minimizes excessive EMI on the feedback paths and voltage gradients in the ground plane, both of which can result in instability or regulation errors. Step-down DC/DCs exhibit discontinuous input current, so the input capacitors should be placed as close as possible to the IC, and avoiding the use of vias if possible. The inductor, input filter capacitor, and output filter capacitor should be connected as close together as possible, with short, direct, and wide traces. The ground nodes for each regulator's power loop should be connected at a single point in a star-ground configuration, and this point should be connected to the backside ground plane with multiple vias. For fixed output voltage options the output node for each regulator should be connected to its corresponding FB pin through the shortest possible route, while keeping sufficient distance from switching nodes to prevent noise injection. Adjustable output versions should follow the same guidelines, but additionally connect the feedback resistors to the FB pin as close to the IC as possible to minimize noise injection.

TYPICAL PERFORMANCE CHARACTERISTICS

( $V_{IN} = V_{EN} = 3.6V$ ,  $T_A = 25^\circ C$ , unless otherwise specified.)

Startup Waveform

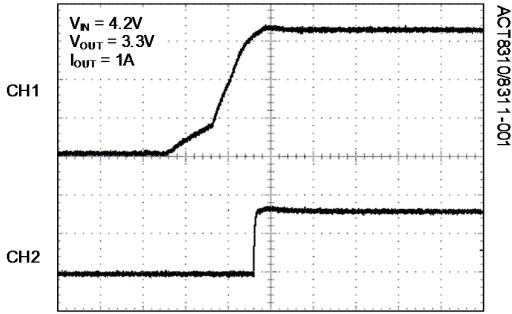

Load Transient Response

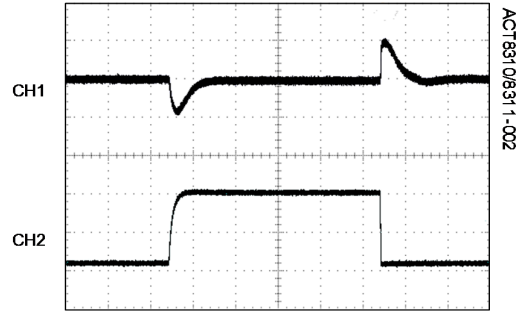

ACT8310 Efficiency vs. Load Current

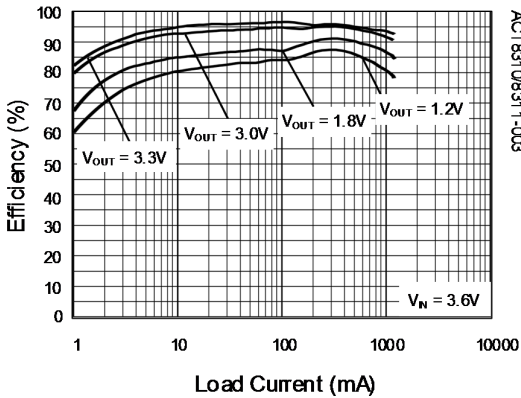

ACT8310 Dropout Voltage vs. Load Current

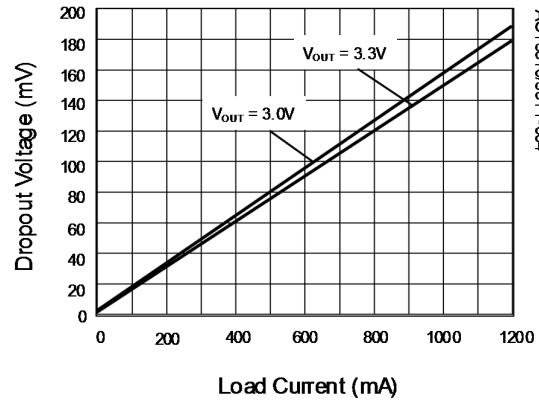

ACT8311 Efficiency vs. Load Current

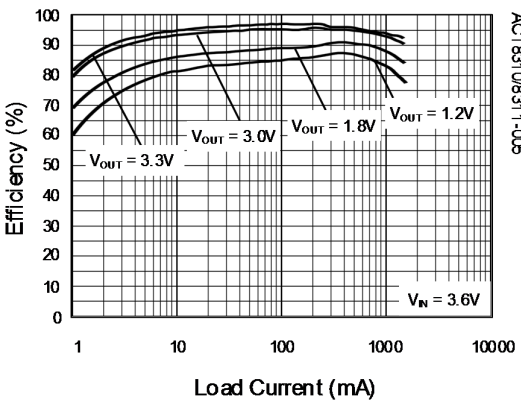

ACT8311 Dropout Voltage vs. Load Current

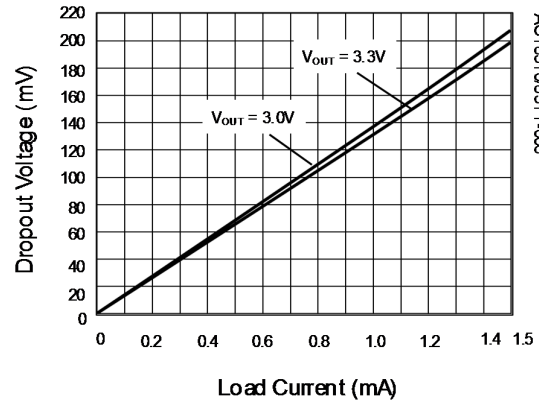



PACKAGE OUTLINE AND DIMENSIONS

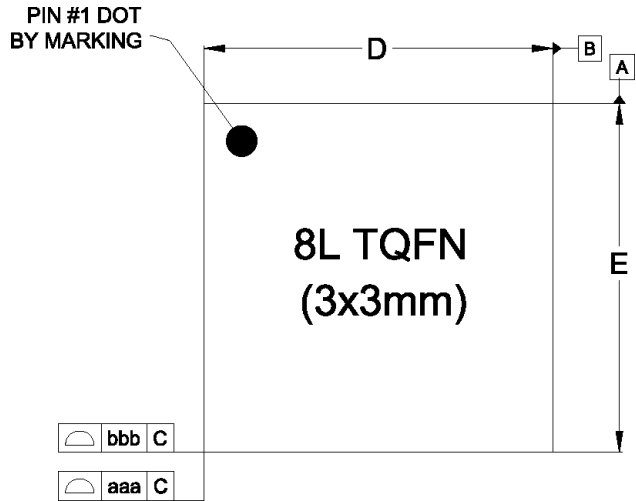

Top View

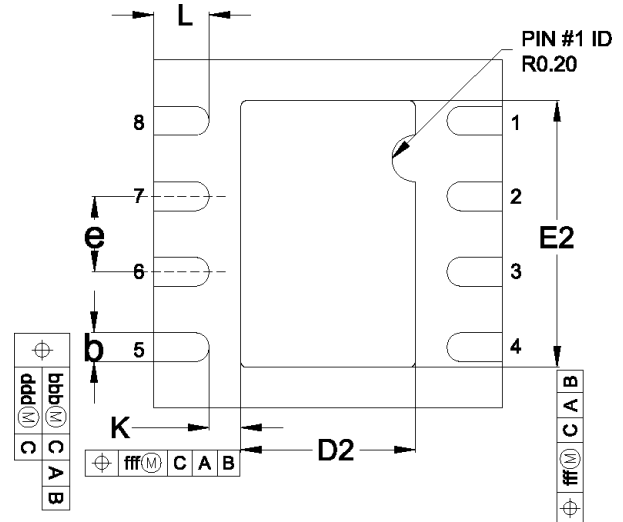

Bottom View

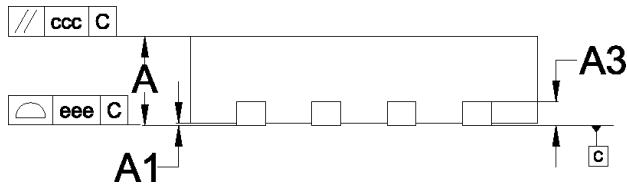

Side View

Dimensional Ref.			
REF.	Min.	Nom.	Max.
A	0.700	0.750	0.800
A1	0.000	---	0.050
A3	0.203 Ref.		
D	3.0BSC		
E	3.0BSC		
D2	1.400	1.500	1.600
E2	2.200	2.300	2.400
--	--		
b	0.200	0.250	0.300
e	0.650 BSC		
L	0.375	0.475	0.575
K	0.275 Ref.		
Tol. of Form&Position			
aaa	0.05		
bbb	0.10		
ccc	0.10		
ddd	0.05		
eee	0.08		
fff	0.10		

Notes

1. ALL DIMENSIONS AND TOLERANCES CONFORM TO ASME Y14.5-2009.
2. ALL DIMENSIONS ARE IN MILLIMETERS.
3. UNILATERAL COPLANARITY ZONE APPLIES TO THE EXPOSED PAD AS WELL AS THE TERMINALS.

## Product Compliance

---

This part complies with RoHS directive 2011/65/EU as amended by (EU) 2015/863.

This part also has the following attributes:

- Lead Free
- Halogen Free (Chlorine, Bromine)



## Contact Information

---

For the latest specifications, additional product information, worldwide sales and distribution locations:

Web: [www.qorvo.com](http://www.qorvo.com)

Tel: 1-844-890-8163

Email: [customer.support@qorvo.com](mailto:customer.support@qorvo.com)

For technical questions and application information:

Email: [appsupport@qorvo.com](mailto:appsupport@qorvo.com)

## Important Notice

---

The information contained herein is believed to be reliable; however, Qorvo makes no warranties regarding the information contained herein and assumes no responsibility or liability whatsoever for the use of the information contained herein. All information contained herein is subject to change without notice. Customers should obtain and verify the latest relevant information before placing orders for Qorvo products. The information contained herein or any use of such information does not grant, explicitly or implicitly, to any party any patent rights, licenses, or any other intellectual property rights, whether with regard to such information itself or anything described by such information. **THIS INFORMATION DOES NOT CONSTITUTE A WARRANTY WITH RESPECT TO THE PRODUCTS DESCRIBED HEREIN, AND QORVO HEREBY DISCLAIMS ANY AND ALL WARRANTIES WITH RESPECT TO SUCH PRODUCTS WHETHER EXPRESS OR IMPLIED BY LAW, COURSE OF DEALING, COURSE OF PERFORMANCE, USAGE OF TRADE OR OTHERWISE, INCLUDING THE IMPLIED WARRANTIES OF MERCHANTABILITY AND FITNESS FOR A PARTICULAR PURPOSE.**

Without limiting the generality of the foregoing, Qorvo products are not warranted or authorized for use as critical components in medical, life-saving, or life-sustaining applications, or other applications where a failure would reasonably be expected to cause severe personal injury or death.

Copyright 2019 © Qorvo, Inc. | Qorvo® and Active-Semi® are trademarks of Qorvo, Inc.