

ACT8500 64-Channel Analog Multiplexer Module Radiation Tolerant & ESD Protected

www.aeroflex.com/mux

May 5, 2014



FEATURES

- 64-Channels provided by six 16-channel multiplexers
- Radiation performance
 - Total dose: 300 krads(Si), Dose rate = 50 - 300 rads(Si)/s
 - SEU: Immune up to 120 MeV-cm²/mg
 - SEL: Immune by process design
- Full military temperature range
- Low power consumption < 90mW
- Two address buses (A0-3 & B0-3) and four enable lines afford flexible organization.
- All channel inputs are protected by ±20V nominal Transorbs.
- Fast access time < 1500ns typical
- Break-Before-Make switching
- High analog input impedance (power on or off)
- Designed for aerospace and high reliability space applications
- Packaging – Hermetic ceramic
 - 96 leads, 1.32" Sq x 0.20"Ht quad flat pack
 - Typical Weight 15 grams
- Aeroflex Plainview's Radiation Hardness Assurance Plan is DLA Certified to MIL-PRF-38534, Appendix G.

GENERAL DESCRIPTION

Aeroflex's ACT8500 is a radiation tolerant, 64 channel multiplexer MCM (multi-chip module) with electrostatic discharge (ESD) protection on all channel inputs.

The ACT8500 has been specifically designed to meet exposure to radiation environments. It is available in a 96 lead High Temperature Co-Fired Ceramic (HTCC) Quad Flatpack (CQFP). It is guaranteed operational from -55°C to +125°C. Available screened in accordance with MIL-PRF-38534, the ACT8500 is ideal for demanding military and space applications.

ORGANIZATION AND APPLICATION

The ACT8500 consists of six 16 channel multiplexers arranged as shown in the Block Diagram. The ACT8500 design is inherently radiation tolerant.

A SECTION

Thirty-two (32) channels addressable by bus A₀~A₃, in two 16 channel blocks, each block enabled separately. Each block connects the addressed channel to two outputs, "Output" and "Current". This technique enables selecting and reading a remote resistive sensor without the multiplexer resistance being part of the measurement. For grounded sensors, this is done by passing current to the sensor by means of the "Current" pin and reading the resultant voltage (proportional to the sensor resistance) at the "Output" pin.

B SECTION

Thirty-two (32) channels addressable by bus B₀~B₃, in two 16 channel blocks, each block enabled separately. Each block connects the addressed channel to one output. By paralleling the channel inputs and enables, this section can be converted to act like one of the 16 channel blocks of the A section.

SECTION B

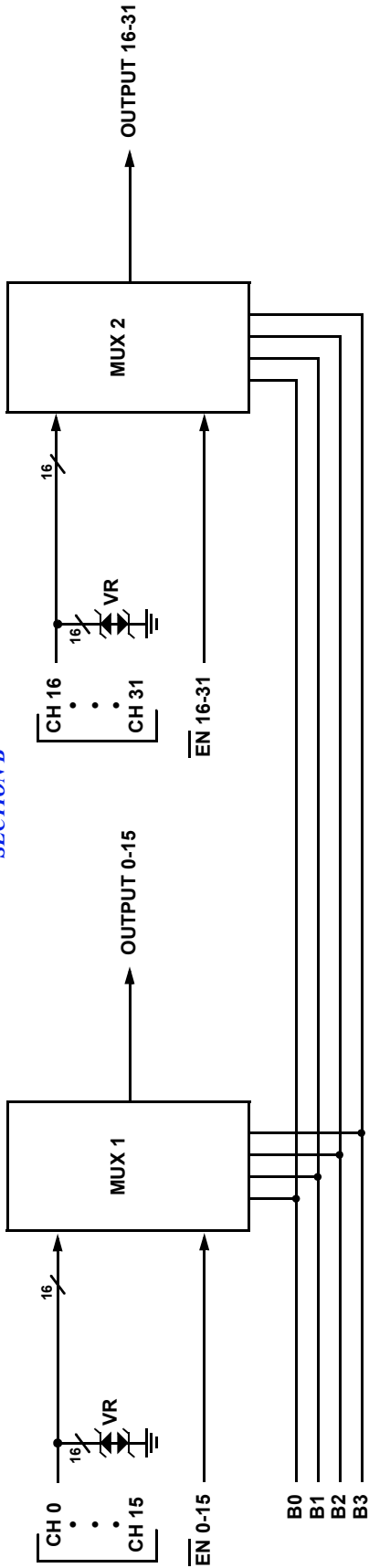

SECTION A

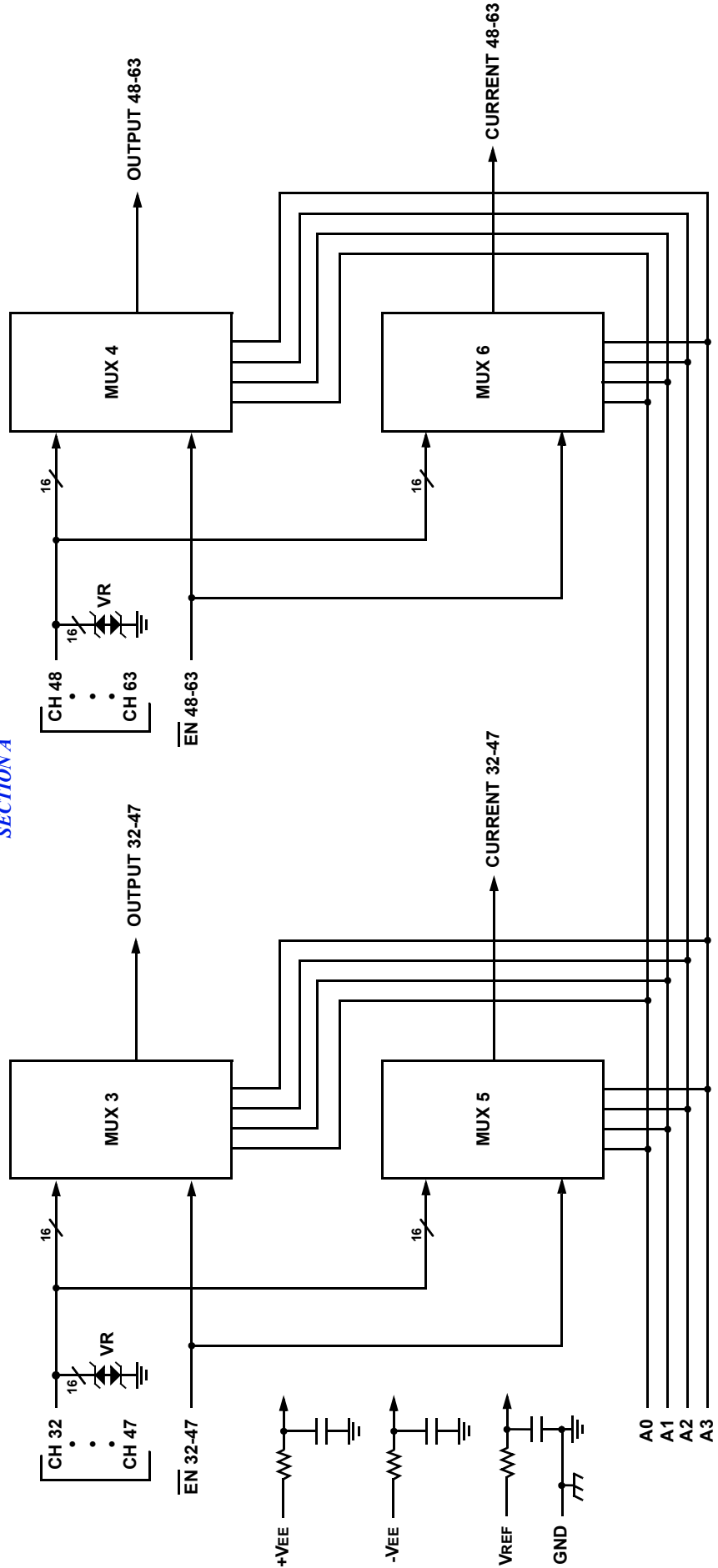

ACT8500 64-CHANNEL ANALOG MUX BLOCK DIAGRAM

ABSOLUTE MAXIMUM RATINGS ^{1/}

Parameter	Range	Units
Case Operating Temperature Range	-55 to +125	°C
Storage Temperature Range	-65 to +150	°C
Supply Voltage +VEE (Pin 44) -VEE (Pin 46) VREF (Pin 48)	+16.5 -16.5 +16.5	V V V
Digital Input Overvoltage VEN (Pins 5, 6, 91, 92), VA (Pins 1, 3, 93, 95), VB (Pins 2, 4, 94, 96)	< VR +4 > GND -4	V V
Analog Input Over Voltage VS	±18V	V

Notes:

^{1/} All measurements are made with respect to ground.

NOTICE: Stresses above those listed under "Absolute Maximum Ratings" may cause permanent damage to the device. These are stress rating only; functional operation beyond the "Operation Conditions" is not recommended and extended exposure beyond the "Operation Conditions" may affect device reliability.

RECOMMENDED OPERATING CONDITIONS ^{1/}

Symbol	Parameter	Typical	Units
+VEE	+15V Power Supply Voltage	+15.0	V
-VEE	-15V Power Supply Voltage	-15.0	V
VREF	Reference Voltage	+5.00	V
VAL	Logic Low Level	+0.8	V
VAH	Logic High Level	+4.0	V

Notes:

^{1/} Power Supply turn-on sequence shall be as follows: +VEE, -VEE, followed by VREF.

DC ELECTRICAL PERFORMANCE CHARACTERISTICS ^{1/}

(Tc = -55°C to +125°C, +VEE = +15V, -VEE = -15V, VREF = 5.0V - Unless otherwise specified)

Parameter	Symbol	Conditions	Min	Max	Units
Supply Current	+IEE	VEN(0-63) = VA(0-3)A = VA(0-3)B = 0	0.3	3	mA
	-IEE		-3	-0.3	mA
	+ISBY	VEN(0-63) = 4V, VA(0-3)A = VA(0-3)B = 0 ^{6/}	0.3	3	mA
	-ISBY		-3	-0.3	mA
Address Input Current	I _{AL} (0-3)B	VB = 0V ^{1/} , ^{7/}	-2	2	µA
	I _{AH} (0-3)B	VB = 5V ^{1/} , ^{7/}	-2	2	µA
	I _{AL} (0-3)A	VB = 0V ^{1/} , ^{7/}	-4	4	µA
	I _{AH} (0-3)A	VB = 5V ^{1/} , ^{7/}	-4	4	µA
Enable Input Current	I _{ENL} (0-15)	VEN(0-15) = 0V ^{7/}	-1	1	µA
	I _{ENH} (0-15)	VEN(0-15) = 5V ^{7/}	-1	1	µA
	I _{ENL} (16-31)	VEN(16-31) = 0V ^{7/}	-1	1	µA
	I _{ENH} (16-31)	VEN(16-31) = 5V ^{7/}	-1	1	µA
	I _{ENL} (32-47)	VEN(32-47) = 0V ^{7/}	-2	2	µA
	I _{ENH} (32-47)	VEN(32-47) = 5V ^{7/}	-2	2	µA
	I _{ENL} (48-63)	VEN(48-63) = 0V ^{7/}	-2	2	µA
I _{ENH} (48-63)	VEN(48-63) = 5V ^{7/}	-2	2	µA	

DC ELECTRICAL PERFORMANCE CHARACTERISTICS 1/ (continued)

(T_c = -55°C to +125°C, +V_{EE} = +15V, -V_{EE} = -15V, V_{REF} = 5.0V - Unless otherwise specified)

Parameter	Symbol	Conditions	Min	Max	Units	
Positive Input Leakage Current CH0-CH63	+ISOFFOUTPUT	V _{IN} = +10V, V _{EN} = 4V, output and all unused MUX inputs under test = -10V <u>2/</u> , <u>3/</u> , <u>7/</u>	-100	+700	nA	
	+ISOFFCURRENT		-100	+700	nA	
Negative Input Leakage Current CH0-CH63	-ISOFFOUTPUT	V _{IN} = -10V, V _{EN} = 4V, output and all unused MUX inputs under test = +10V <u>2/</u> , <u>3/</u> , <u>7/</u>	-100	+700	nA	
	-ISOFFCURRENT		-100	+700	nA	
Output Leakage Current OUTPUTS (pins 25, 26, 68 & 70) CURRENTS (pins 67 & 69)	+IDOFFOUTPUT	V _{OUT} = +10V, V _{EN} = 4V, output and all unused MUX inputs under test = -10V <u>3/</u> , <u>4/</u> , <u>7/</u>	-100	+100	nA	
	+IDOFFCURRENT		-100	+100	nA	
Output Leakage Current OUTPUTS (pins 25, 26, 68 & 70) CURRENTS (pins 67 & 69)	-IDOFFOUTPUT	V _{OUT} = -10V, V _{EN} = 4V, output and all unused MUX inputs under test = +10V <u>3/</u> , <u>4/</u> , <u>7/</u>	-100	+100	nA	
	-IDOFFCURRENT		-100	+100	nA	
Input Clamped Voltage CH0 - CH63	+VCLMP(0-63)	V _{EN} = 4V, all unused MUX inputs under test are open. <u>3/</u>	+25°C	18.0	23.0	V
			+125°C	18.0	23.5	V
			-55°C	17.5	22.5	V
Input Clamped Voltage CH0 - CH63	-VCLMP(0-63)		+25°C	-23.0	-18.0	V
			+125°C	-23.5	-18.0	V
			-55°C	-22.5	-17.5	V
Switch ON Resistance OUTPUTS (pins 25, 26, 68 & 70)	RDS(ON)(0-63) _A	V _{IN} = +15V, V _{EN} = 0.8V, I _{OUT} = -1mA <u>2/</u> , <u>3/</u> , <u>5/</u>	500	3000	Ω	
	RDS(ON)(0-63) _B	V _{IN} = +5V, V _{EN} = 0.8V, I _{OUT} = -1mA <u>2/</u> , <u>3/</u> , <u>5/</u>	500	3000	Ω	
	RDS(ON)(0-63) _C	V _{IN} = -5V, V _{EN} = 0.8V, I _{OUT} = +1mA <u>2/</u> , <u>3/</u> , <u>5/</u>	500	3000	Ω	
Switch ON Resistance CURRENTS (pins 67 & 69) <u>6/</u>	RDS(ON)(32-63) _A	V _{IN} = +15V, V _{EN} = 0.8V, I _{OUT} = -1mA <u>2/</u> , <u>3/</u> , <u>5/</u>	500	3000	Ω	
	RDS(ON)(32-63) _B	V _{IN} = +5V, V _{EN} = 0.8V, I _{OUT} = -1mA <u>2/</u> , <u>3/</u> , <u>5/</u>	500	3000	Ω	
	RDS(ON)(32-63) _C	V _{IN} = -5V, V _{EN} = 0.8V, I _{OUT} = +1mA <u>2/</u> , <u>3/</u> , <u>5/</u>	500	3000	Ω	

Notes:

- 1/ Measure inputs sequentially. Ground all unused inputs of the device under test. V_A is the applied input voltage to the address lines A(0-3). V_B is the applied input voltage to the address lines B(0-3).
- 2/ V_{IN} is the applied input voltage to the input channels CH0-CH63.
- 3/ V_{EN} is the applied input voltage to the enable lines EN (0-15), EN (16-31), EN (32-47) and EN (48-63).
- 4/ V_{OUT} is the applied input voltage to the output lines OUTPUT(0-15), OUTPUT(16-31), OUTPUT(32-47), OUTPUT(48-63), CURRENT(32-47) and CURRENT(48-63).
- 5/ Negative current is the current flowing out of each of the MUX pins. Positive current is the current flowing into each MUX pin.
- 6/ If not tested, shall be guaranteed to the specified limits.
- 7/ These parameters for T_c = -55°C are guaranteed by design, characterization, or correlation to other test parameters but not production tested.

SWITCHING CHARACTERISTICS

(T_c = -55°C to +125°C, +V_{EE} = +15V, -V_{EE} = -15V, V_{REF} = 5.0V -- Unless otherwise specified)

Parameter	Symbol	Conditions	Min	Max	Units
Switching Test MUX	t _{AHL}	R _L = 10KΩ, C _L = 50pF	10	1500	ns
	t _{ALH}	R _L = 10KΩ, C _L = 50pF T _c = +25°C, +125°C T _c = -55°C	10	2000	ns
			10	5000	ns
	t _{ONEN}	R _L = 1KΩ, C _L = 50pF	10	1500	ns
t _{OFFEN}	10		1000	ns	

TRUTH TABLE (CH0 – CH15)

B3	B2	B1	B0	EN(0-15)	"ON" CHANNEL ^{1/}
X	X	X	X	H	NONE
L	L	L	L	L	CH0
L	L	L	H	L	CH1
L	L	H	L	L	CH2
L	L	H	H	L	CH3
L	H	L	L	L	CH4
L	H	L	H	L	CH5
L	H	H	L	L	CH6
L	H	H	H	L	CH7
H	L	L	L	L	CH8
H	L	L	H	L	CH9
H	L	H	L	L	CH10
H	L	H	H	L	CH11
H	H	L	L	L	CH12
H	H	L	H	L	CH13
H	H	H	L	L	CH14
H	H	H	H	L	CH15

^{1/} Between CH0-15 and OUTPUT (0-15)

TRUTH TABLE (CH16 – CH31)

B3	B2	B1	B0	EN(16-31)	"ON" CHANNEL ^{1/}
X	X	X	X	H	NONE
L	L	L	L	L	CH16
L	L	L	H	L	CH17
L	L	H	L	L	CH18
L	L	H	H	L	CH19
L	H	L	L	L	CH20
L	H	L	H	L	CH21
L	H	H	L	L	CH22
L	H	H	H	L	CH23
H	L	L	L	L	CH24
H	L	L	H	L	CH25
H	L	H	L	L	CH26
H	L	H	H	L	CH27
H	H	L	L	L	CH28
H	H	L	H	L	CH29
H	H	H	L	L	CH30
H	H	H	H	L	CH31

^{1/} Between CH16-31 and OUTPUT (16-31)

TRUTH TABLE (CH32 – CH47)

A3	A2	A1	A0	EN(32-47)	"ON" CHANNEL ^{1/}
X	X	X	X	H	NONE
L	L	L	L	L	CH32
L	L	L	H	L	CH33
L	L	H	L	L	CH34
L	L	H	H	L	CH35
L	H	L	L	L	CH36
L	H	L	H	L	CH37
L	H	H	L	L	CH38
L	H	H	H	L	CH39
H	L	L	L	L	CH40
H	L	L	H	L	CH41
H	L	H	L	L	CH42
H	L	H	H	L	CH43
H	H	L	L	L	CH44
H	H	L	H	L	CH45
H	H	H	L	L	CH46
H	H	H	H	L	CH47

^{1/} Between CH32-47 and OUTPUT (32-47) and CURRENT (32-47)

TRUTH TABLE (CH48 – CH63)

A3	A2	A1	A0	EN(48-63)	"ON" CHANNEL ^{1/}
X	X	X	X	H	NONE
L	L	L	L	L	CH48
L	L	L	H	L	CH49
L	L	H	L	L	CH50
L	L	H	H	L	CH51
L	H	L	L	L	CH52
L	H	L	H	L	CH53
L	H	H	L	L	CH54
L	H	H	H	L	CH55
H	L	L	L	L	CH56
H	L	L	H	L	CH57
H	L	H	L	L	CH58
H	L	H	H	L	CH59
H	H	L	L	L	CH60
H	H	L	H	L	CH61
H	H	H	L	L	CH62
H	H	H	H	L	CH63

^{1/} Between CH48-63 and OUTPUT (48-63) and CURRENT (48-63)

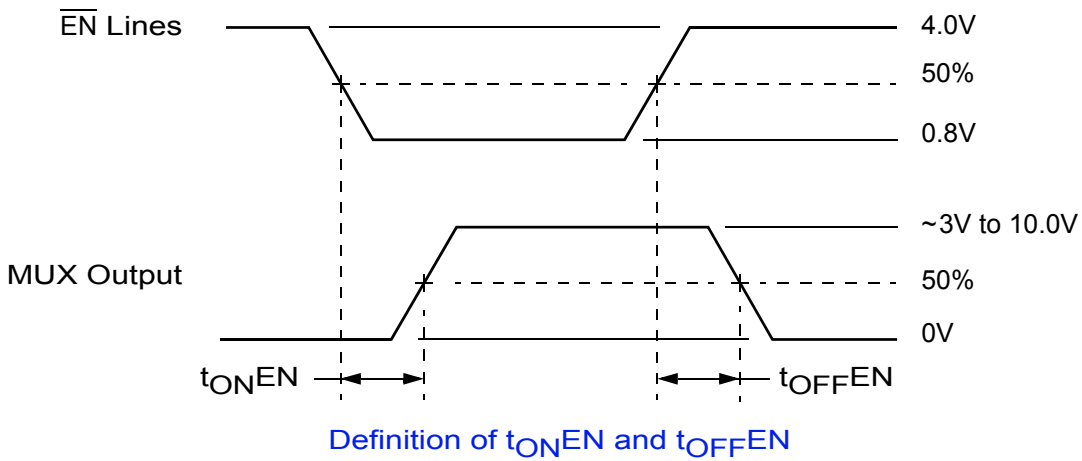
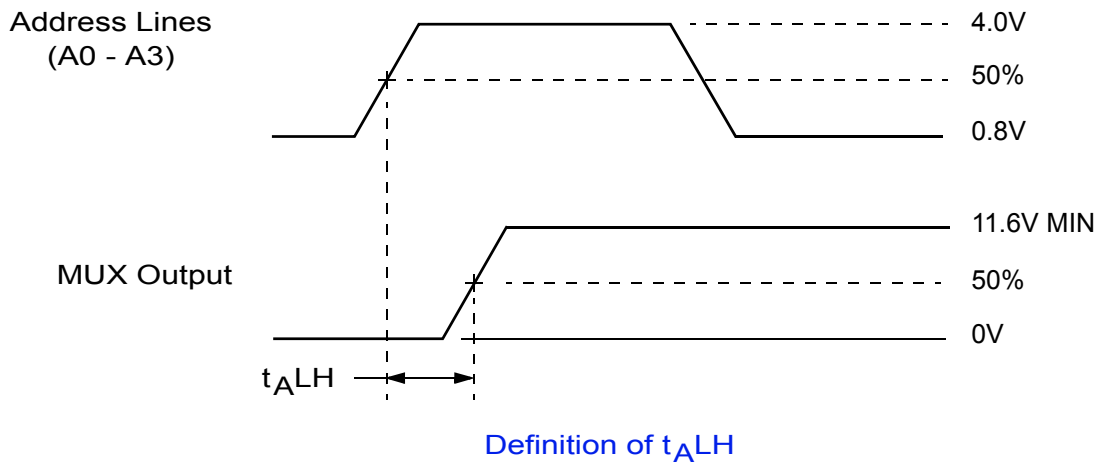
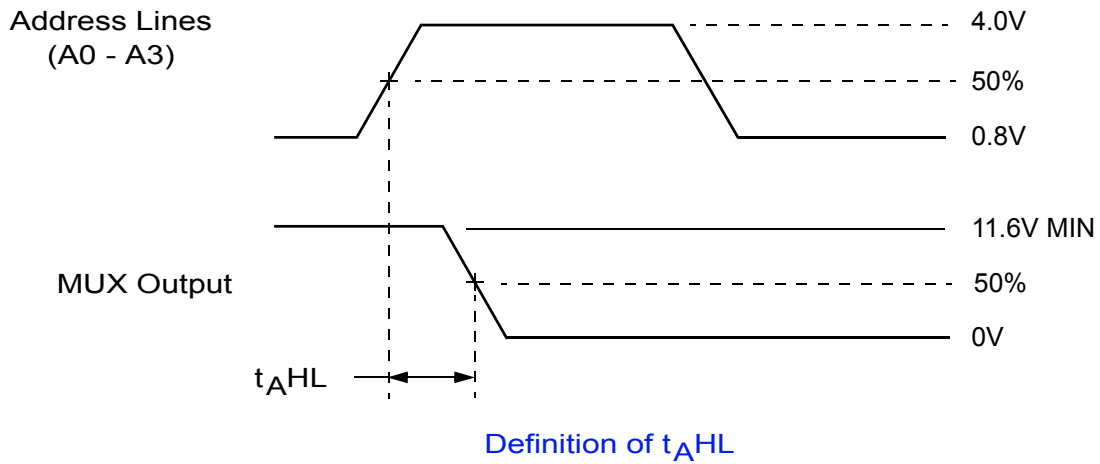

NOTE: $f = 10\text{KHz}$, Duty cycle = 50%.

ACT8500 SWITCHING DIAGRAMS

PIN NUMBERS & FUNCTIONS

ACT8500 – 96 Leads Ceramic QUAD Flat Pack					
Pin #	Function	Pin #	Function	Pin #	Function
1	A2	33	CH11	65	CH49
2	B2	34	CH27	66	CH48
3	A3	35	CH12	67	Output I(48-63)
4	B3	36	CH28	68	Output V(48-63)
5	$\overline{\text{EN}}$ 0-15	37	CH13	69	Output I(32-47)
6	$\overline{\text{EN}}$ 16-31	38	CH29	70	Output V(32-47)
7	CH0	39	CH14	71	GND
8	CH16	40	CH30	72	GND
9	CH1	41	CH15	73	CH47
10	CH17	42	CH31	74	CH46
11	CH2	43	NC	75	CH45
12	CH18	44	+VEE	76	CH44
13	CH3	45	NC	77	CH43
14	CH19	46	-VEE	78	CH42
15	CH4	47	NC	79	CH41
16	CH20	48	VREF	80	CH40
17	CH5	49	NC	81	CH39
18	CH21	50	CASE GND	82	CH38
19	CH6	51	CH63	83	CH37
20	CH22	52	CH62	84	CH36
21	CH7	53	CH61	85	CH35
22	CH23	54	CH60	86	CH34
23	GND	55	CH59	87	CH33
24	GND	56	CH58	88	CH32
25	Output V(0-15)	57	CH57	89	GND
26	Output V(16-31)	58	CH56	90	GND
27	CH8	59	CH55	91	$\overline{\text{EN}}$ 48-63
28	CH24	60	CH54	92	$\overline{\text{EN}}$ 32-47
29	CH9	61	CH53	93	A0
30	CH25	62	CH52	94	B0
31	CH10	63	CH51	95	A1
32	CH26	64	CH50	96	B1

NOTE: It is recommended that all "NC" or "no connect pin" be grounded. This eliminates or minimizes any ESD or static buildup.

ORDERING INFORMATION

Model Number	DLA SMD #	Screening	Package
ACT8500-7	-	Commercial Flow, +25°C testing only	QUAD Flat Pack
ACT8500-S	5962-0050201KXC	In accordance with DLA SMD	
ACT8500-901-1S	5962F0050201KXC	In accordance with DLA Certified RHA Program Plan to RHA Level "F", 300krads(Si)	

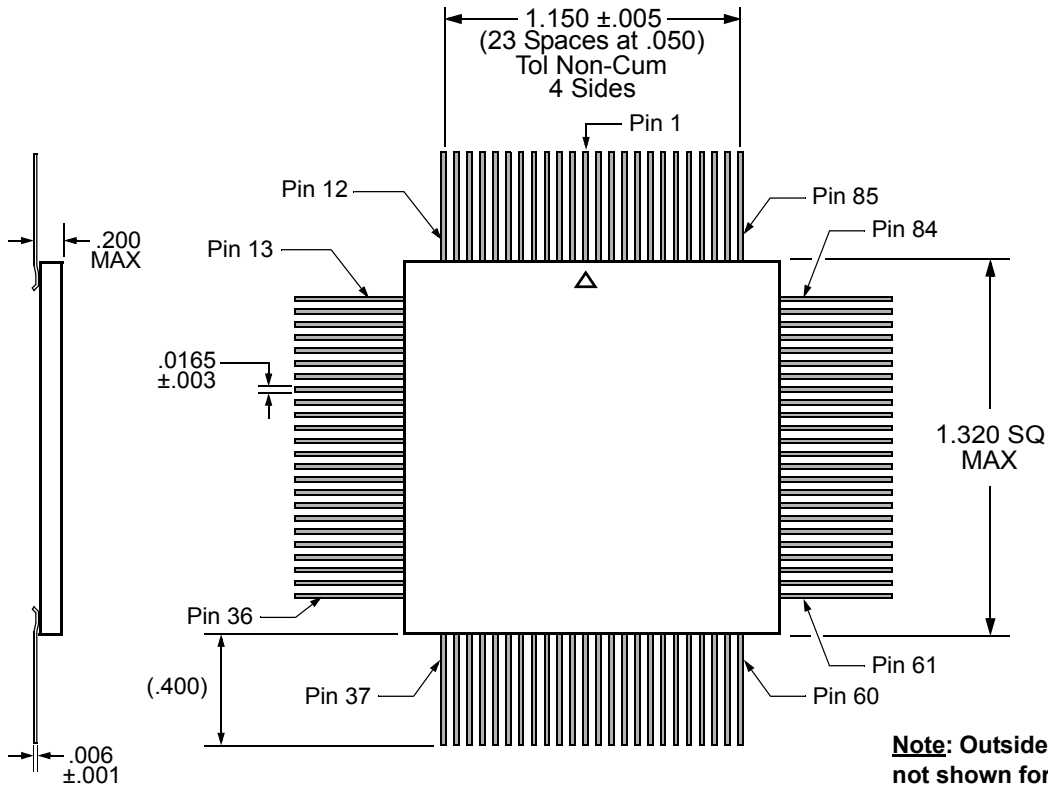

Note: Outside ceramic tie bars not shown for clarity. Contact factory for details.

FLAT PACKAGE OUTLINE

EXPORT CONTROL:

This product is controlled for export under the International Traffic in Arms Regulations (ITAR). A license from the U.S. Government is required prior to the export of this product from the United States.

www.aeroflex.com/HiRel info-ams@aeroflex.com

Datasheet Definitions:

Advanced Preliminary Datasheet	Product in Development Shipping Non-Flight Prototypes Shipping QML and Reduced HiRel
--------------------------------	--



Aeroflex Plainview, Inc. reserves the right to make changes to any products and services described herein at any time without notice. Consult Aeroflex or an authorized sales representative to verify that the information in this data sheet is current before using this product. Aeroflex does not assume any responsibility or liability arising out of the application or use of any product or service described herein, except as expressly agreed to in writing by Aeroflex; nor does the purchase, lease, or use of a product or service from Aeroflex convey a license under any patent rights, copyrights, trademark rights, or any other of the intellectual rights of Aeroflex or of third parties.

Our passion for performance is defined by three attributes.



Solution-Minded



Performance-Driven



Customer-Focused