

Standard Products

ACT8505 64-Channel Analog Multiplexer Module Radiation Tolerant With MUX Output Monitor Function

www.aeroflex.com/RADHARD

September 29, 2008



FEATURES

- Radiation Performance
 - Radiation 300K(Si) Total Dose
 - No Latch-Up or SEE to 120MeV/cm²/mg
- Full Military Temperature Range
- Low Power Consumption < 75mW, Typically 50mW
- 64 Channels Provided by Four (4) HS-1840RH Multiplexers
- Address Bus (A0-3), and Four Enable lines afford flexible organization
- Output Monitoring of HS-1840RH outputs to a Fifth HS1840RH. Controlled with C0, C1 Address Lines
- Fast Access Time 1500ns
- ±35V Input Over Voltage Protection (Power On or Off)
- Break-Before-Make Switching
- High Analog Input Impedance (with Power On or Off)
- No Latch-Up
- Designed for commercial, industrial and aerospace applications
- Same *Form / Fit / Function* as ACT8504 but no input Transorbs
- Packaging – Hermetic Ceramic Quad Flat Pack
 - 96 Leads, 1.32" Sq x .20"Ht Quad Flat Pack
 - Typical Weight 15 grams
- DSCC SMD 5962-0520902*

NOTE: Aeroflex Plainview does not currently have a DSCC Certified Radiation Hardened Assurance Program

** Not approved for RAD Hard Version of SMD at this time
Radiation information available upon request*

GENERAL DESCRIPTION

Aeroflex's ACT8505 is a radiation tolerant, 64 channel multiplexer MCM (multi-chip module) with ESD protection for use in space applications. It is designed to provide a high input impedance with power on or off.

The ACT8505 has been specifically designed to meet exposure to radiation environments. It is available in a 96 lead High Temperature Co-Fired Ceramic (HTCC) Quad Flatpack (QFP). The module is guaranteed operational from -55°C to +125°C and is ideal for demanding military and space applications.

ORGANIZATION AND APPLICATION

The ACT8505 consists of four 16 channel multiplexers arranged as shown in the Block Diagram. The Multiplexer channels 0-63 are controlled by address lines A₀-A₃. The mux output monitor is controlled by address lines C₀ and C₁.

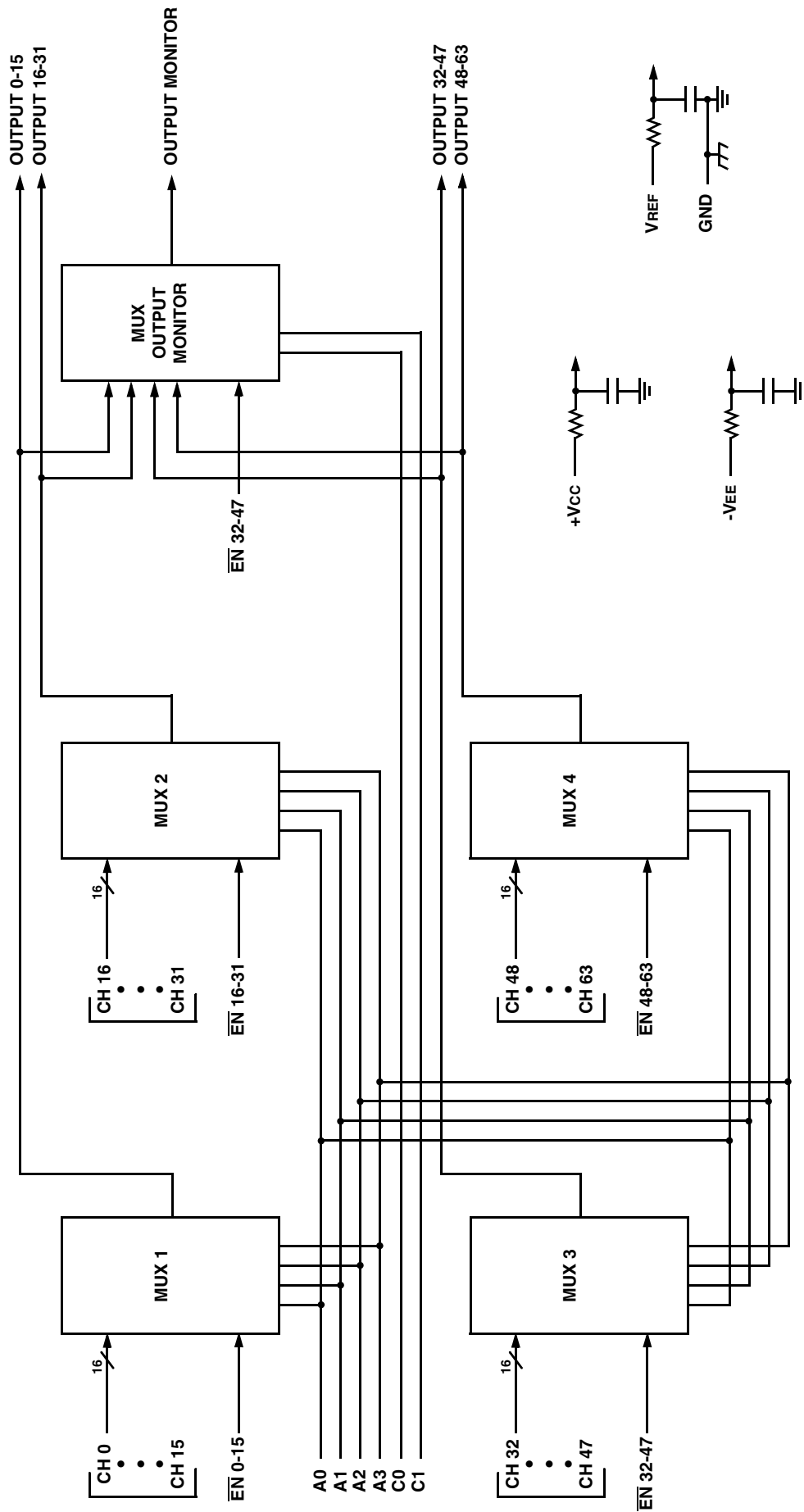

ACT8505 64 Channel Analog MUX Block Diagram

ABSOLUTE MAXIMUM RATINGS 1/

Parameter	Range	Units
Case Operating Temperature Range	-55 to +125	°C
Storage Temperature Range	-55 to +150	°C
Supply Voltage +VCC (Pin 44) -VEE (Pin 46) VREF (Pin 48)	+20 -20 +20	V V V
Digital Input Overvoltage VEN (Pins 5, 6, 91, 92), VA (Pins 93, 95, 1, 3), Vc (Pins 2, 4)	< VR +4 > GND -4	V V
Analog Input Over Voltage VS	±18	V

Notes:

1/ All measurements are made with respect to ground.

NOTICE: Stresses above those listed under "Absolute Maximums Rating" may cause permanent damage to the device. These are stress rating only; functional operation beyond the "Operation Conditions" is not recommended and extended exposure beyond the "Operation Conditions" may effect device reliability.

RECOMMENDED OPERATING CONDITIONS

Symbol	Parameter	Typical	Units
+VCC	+15V Power Supply Voltage	+15.0	V
-VEE	-15V Power Supply Voltage	-15.0	V
VREF	Reference Voltage	+5.00	V
VAL	Logic Low Level	+0.8	V
VAH	Logic High Level	+4.0	V

DC ELECTRICAL PERFORMANCE CHARACTERISTICS 1/

(Tc = -55°C to +125°C, +VEE = +15V, -VEE = -15V, VREF = +5.0V, Unless otherwise specified)

Parameter	Symbol	Conditions	Min	Max	Units
Supply Current	I+	VEN(0-63) = VA(0-3)A = VC(0-1)C = 0	.25	2.5	mA
	I-	VEN(0-63) = VA(0-3)A = VA(0-1)C = 0	-2.5	-.25	mA
	+ISBY	VEN(0-63) = 4V, VA(0-3)A = VA(0-1)C = 0 6/	.25	2.5	mA
	-ISBY	VEN(0-63) = 4V, VA(0-3)A = VA(0-1)C = 0 6/	-2.5	-.25	mA
Address Input Current	I _{AL} (0-3)A	VA = 0V 1/	-4	4	μA
	I _{AH} (0-3)A	VA = 5V 1/	-4	4	μA
	I _{AL} (0-1)C	VA = 0V 1/	-1	1	μA
	I _{AH} (0-1)C	VA = 5V 1/	-1	1	μA
Enable Input Current	I _{ENL} (0-15)	VEN(0-15) = 0V	-1	1	μA
	I _{ENH} (0-15)	VEN(0-15) = 5V	-1	1	μA
	I _{ENL} (16-31)	VEN(16-31) = 0V	-1	1	μA
	I _{ENH} (16-31)	VEN(16-31) = 5V	-1	1	μA
	I _{ENL} (32-47),(MUXMON)	VEN(32-47), VEN(MUXMON) = 0V	-2	2	μA
	I _{ENH} (32-47),(MUXMON)	VEN(32-47), VEN(MUXMON) = 5V	-2	2	μA
	I _{ENL} (48-63)	VEN(48-63) = 0V	-1	1	μA
	I _{ENH} (48-63)	VEN(48-63) = 5V	-1	1	μA

DC ELECTRICAL PERFORMANCE CHARACTERISTICS 1/ (con't)

(Tc = -55°C to +125°C, +VEE = +15V, -VEE = -15V, VREF = +5.0V, Unless otherwise specified)

Parameter	Symbol	Conditions	Min	Max	Units
Positive Input Leakage Current CH0-CH63	+ISOFFOUTPUT(ALL)	VIN = +10V, VEN = 4V, output and all unused MUX inputs under test = -10V 2/, 3/	-100	+200	nA
	+ISOFFCURRENT(ALL)		-100	+200	nA
Negative Input Leakage Current CH0-CH63	-ISOFFOUTPUT(ALL)	VIN = -10V, VEN = 4V, output and all unused MUX inputs under test = +10V 2/, 3/	-100	+200	nA
	-ISOFFCURRENT(ALL)		-100	+200	nA
Output Leakage Current OUTPUTS (pins 25, 26, 68 & 70) Mux Monitor (pin 69) 6/	+IDOFFOUTPUT(ALL)	VOUT = +10V, VEN = 4V, output and all unused MUX inputs under test = -10V 3/, 4/	-100	+100	nA
	+IDOFFCURRENT(ALL)		-100	+100	nA
Output Leakage Current OUTPUTS (pins 25, 26, 68 & 70) Mux Monitor (pin 69) 6/	-IDOFFOUTPUT(ALL)	VOUT = -10V, VEN = 4V, output and all unused MUX inputs under test = +10V 3/, 4/	-100	+100	nA
	-IDOFFCURRENT(ALL)		-100	+100	nA
Switch ON Resistance OUTPUTS (pins 25, 26, 68 & 70)	RDS(ON)(0-63) _A	VIN = +15V, VEN = 0.8V, IOU _T = -1mA 2/, 3/, 5/	500	3000	Ω
	RDS(ON)(0-63) _B	VIN = +5V, VEN = 0.8V, IOU _T = -1mA 2/, 3/, 5/	500	3000	Ω
	RDS(ON)(0-63) _C	VIN = -5V, VEN = 0.8V, IOU _T = +1mA 2/, 3/, 5/	500	3000	Ω
Switch ON Resistance Mux Monitor Only (pin 69) 6/	RDS(ON)(32-63) _A	VIN = +15V, VEN = 0.8V, IOU _T = -1mA 2/, 3/, 5/	500	3000	Ω

- Notes:
- 1/ Measure inputs sequentially. Ground all unused inputs of the MUX under test. VA is the applied input voltage to the MUXes' address lines A(0-3).
 - 2/ VIN is the applied input voltage to the MUXes' input channel CH0-CH63.
 - 3/ VEN is the applied input voltage to the MUXes' enable line En(0-15), En(16-31), En(32-47) and En(48-63).
 - 4/ VOUT is the applied input voltage to the MUXes' output line OUTPUT(1-15), OUTPUT(16-31), OUTPUT(32-47) and OUTPUT(48-63).
 - 5/ Negative current is the current flowing out of each of the MUX pins. Positive current is the current flowing into each MUX pin.
 - 6/ If not tested, shall be guaranteed to the specified limits.

SWITCHING CHARACTERISTICS

(Tc = -55°C to +125°C, +VEE = +15V, -VEE = -15V, VREF = +5.0V, Unless otherwise specified)

Parameter	Symbol	Conditions	Min	Max	Units
Switching Test MUX	t _{ONA}	RL = 10KΩ, CL = 50pF	10	1500	ns
	t _{OFFA}	RL = 10KΩ, CL = 50pF Tc = +25°C, +125°C Tc = -55°C	10	2000	ns
			10	5000	ns
	t _{ONEN}	RL = 1KΩ, CL = 50pF	10	1500	ns
t _{OFFEN}	10		1000	ns	

TRUTH TABLE (CH0 – CH15)

A3	A2	A1	A0	EN(0-15)	"ON" CHANNEL <u>1/</u>
X	X	X	X	H	NONE
L	L	L	L	L	CH0
L	L	L	H	L	CH1
L	L	H	L	L	CH2
L	L	H	H	L	CH3
L	H	L	L	L	CH4
L	H	L	H	L	CH5
L	H	H	L	L	CH6
L	H	H	H	L	CH7
H	L	L	L	L	CH8
H	L	L	H	L	CH9
H	L	H	L	L	CH10
H	L	H	H	L	CH11
H	H	L	L	L	CH12
H	H	L	H	L	CH13
H	H	H	L	L	CH14
H	H	H	H	L	CH15

1/ Between CH0-15 and OUTPUT (0-15)

TRUTH TABLE (CH16 – CH31)

A3	A2	A1	A0	EN(16-31)	"ON" CHANNEL <u>1/</u>
X	X	X	X	H	NONE
L	L	L	L	L	CH16
L	L	L	H	L	CH17
L	L	H	L	L	CH18
L	L	H	H	L	CH19
L	H	L	L	L	CH20
L	H	L	H	L	CH21
L	H	H	L	L	CH22
L	H	H	H	L	CH23
H	L	L	L	L	CH24
H	L	L	H	L	CH25
H	L	H	L	L	CH26
H	L	H	H	L	CH27
H	H	L	L	L	CH28
H	H	L	H	L	CH29
H	H	H	L	L	CH30
H	H	H	H	L	CH31

1/ Between CH16-31 and OUTPUT (16-31)

TRUTH TABLE (CH32 – CH47)

A3	A2	A1	A0	EN(32-47)	"ON" CHANNEL 1/
X	X	X	X	H	NONE
L	L	L	L	L	CH32
L	L	L	H	L	CH33
L	L	H	L	L	CH34
L	L	H	H	L	CH35
L	H	L	L	L	CH36
L	H	L	H	L	CH37
L	H	H	L	L	CH38
L	H	H	H	L	CH39
H	L	L	L	L	CH40
H	L	L	H	L	CH41
H	L	H	L	L	CH42
H	L	H	H	L	CH43
H	H	L	L	L	CH44
H	H	L	H	L	CH45
H	H	H	L	L	CH46
H	H	H	H	L	CH47

1/ Between CH32-47 and OUTPUT (32-47)

TRUTH TABLE (CH48 – CH63)

A3	A2	A1	A0	EN(47-63)	"ON" CHANNEL 1/
X	X	X	X	H	NONE
L	L	L	L	L	CH48
L	L	L	H	L	CH49
L	L	H	L	L	CH50
L	L	H	H	L	CH51
L	H	L	L	L	CH52
L	H	L	H	L	CH53
L	H	H	L	L	CH54
L	H	H	H	L	CH55
H	L	L	L	L	CH56
H	L	L	H	L	CH57
H	L	H	L	L	CH58
H	L	H	H	L	CH59
H	H	L	L	L	CH60
H	H	L	H	L	CH61
H	H	H	L	L	CH62
H	H	H	H	L	CH63

1/ Between CH48-63 and OUTPUT (48-63)

TRUTH TABLE (MUX OUTPUT MONITOR)

C1	C0	EN(32-47)	"ON" CHANNEL
X	X	H	NONE
L	L	L	Output Channels 0-15
L	H	L	Output Channels 16-31
H	L	L	Output Channels 32-47
H	H	L	Output Channels 48-63

Address tONA

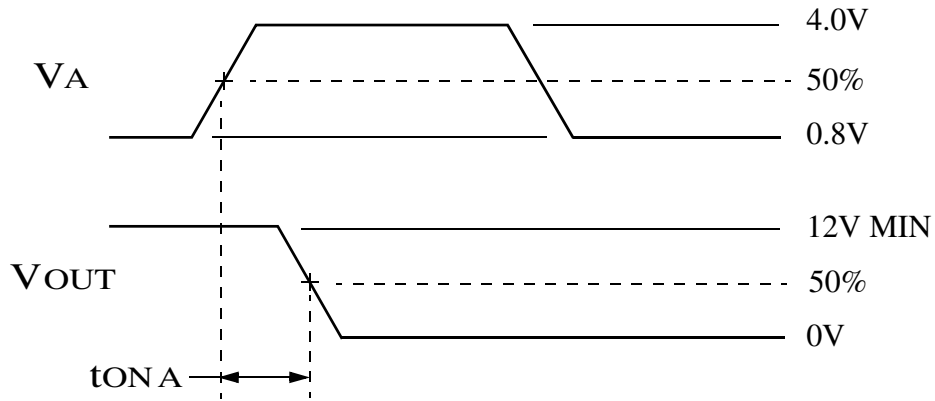

Address toFFA

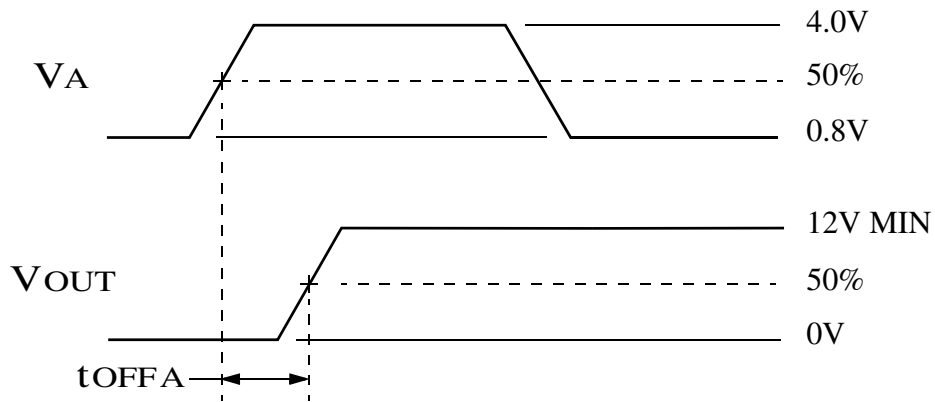

Enable tONEN and toFFEN

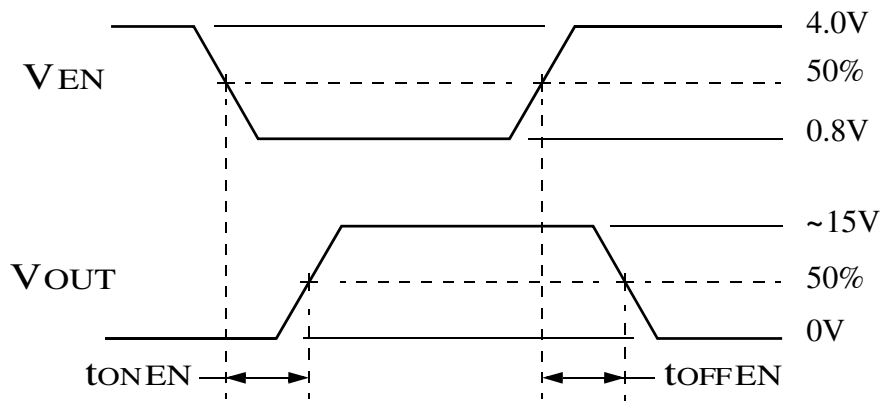

NOTE: $f = 10\text{KHz}$, Duty cycle = 50%.

ACT8505 SWITCHING DIAGRAMS

LEAD NUMBERS & FUNCTIONS

ACT8505 – 96 Leads Ceramic QUAD Flat Pack					
Pin #	Function	Pin #	Function	Pin #	Function
1	A2	33	CH11	65	CH49
2	C0	34	CH27	66	CH48
3	A3	35	CH12	67	NC
4	C1	36	CH28	68	Output V(48-63)
5	\overline{EN} 0-15	37	CH13	69	Mux Output Monitor
6	\overline{EN} 16-31	38	CH29	70	Output V(32-47)
7	CH0	39	CH14	71	GND
8	CH16	40	CH30	72	GND
9	CH1	41	CH15	73	CH47
10	CH17	42	CH31	74	CH46
11	CH2	43	NC	75	CH45
12	CH18	44	+VCC	76	CH44
13	CH3	45	NC	77	CH43
14	CH19	46	-VEE	78	CH42
15	CH4	47	NC	79	CH41
16	CH20	48	VREF	80	CH40
17	CH5	49	NC	81	CH39
18	CH21	50	CASE GND	82	CH38
19	CH6	51	CH63	83	CH37
20	CH22	52	CH62	84	CH36
21	CH7	53	CH61	85	CH35
22	CH23	54	CH60	86	CH34
23	GND	55	CH59	87	CH33
24	GND	56	CH58	88	CH32
25	Output V(0-15)	57	CH57	89	GND
26	Output V(16-31)	58	CH56	90	GND
27	CH8	59	CH55	91	\overline{EN} 48-63
28	CH24	60	CH54	92	\overline{EN} 32-47
29	CH9	61	CH53	93	A0
30	CH25	62	CH52	94	NC
31	CH10	63	CH51	95	A1
32	CH26	64	CH50	96	NC

NOTE: It is recommended that all "NC" or "no connect pin", be grounded. This eliminates or minimizes any ESD or static buildup.

ORDERING INFORMATION

Model Number	Screening	DESC SMD #	Package
ACT8505-S	Military Temperature, -55°C to +125°C, Compliant to MIL-PRF-38534 Class K	NA	QUAD Flat Pack
ACT8505-7	Commercial Flow, +25°C testing only		
ACT8505-201-1S	Military Temperature, -55°C to +125°C, Compliant to MIL-PRF-38534 Class K	5962-0520902KXC	

FLAT PACKAGE OUTLINE

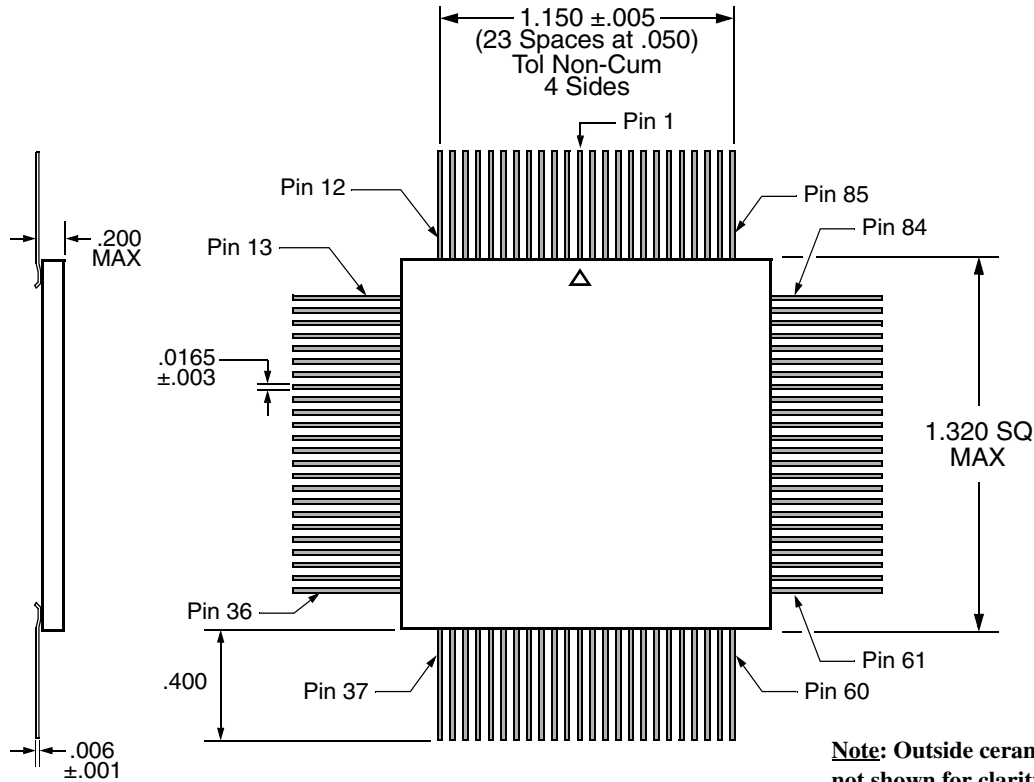

Note: Outside ceramic tie bars not shown for clarity. Contact factory for details.

EXPORT CONTROL:

This product is controlled for export under the International Traffic in Arms Regulations (ITAR). A license from the U.S. Department of State is required prior to the export of this product from the United States.

EXPORT WARNING:

Aeroflex's military and space products are controlled for export under the International Traffic in Arms Regulations (ITAR) and may not be sold or proposed or offered for sale to certain countries. (See ITAR 126.1 for complete information.)

PLAINVIEW, NEW YORK
Toll Free: 800-THE-1553
Fax: 516-694-6715

INTERNATIONAL
Tel: 805-778-9229
Fax: 805-778-1980

NORTHEAST
Tel: 603-888-3975
Fax: 603-888-4585

SE AND MID-ATLANTIC
Tel: 321-951-4164
Fax: 321-951-4254

WEST COAST
Tel: 949-362-2260
Fax: 949-362-2266

CENTRAL
Tel: 719-594-8017
Fax: 719-594-8468

www.aeroflex.com info-ams@aeroflex.com



Aeroflex Microelectronic Solutions reserves the right to change at any time without notice the specifications, design, function, or form of its products described herein. All parameters must be validated for each customer's application by engineering. No liability is assumed as a result of use of this product. No patent licenses are implied.



Our passion for performance is defined by three attributes represented by these three icons: solution-minded, performance-driven and customer-focused