

ACT8506 48-Channel Analog Multiplexer Module Radiation Tolerant

www.aeroflex.com/mux

May 5, 2014



FEATURES

- 48 channels provided by six 16-channel multiplexers
- Radiation performance
 - Total dose: 300 krad(Si), Dose rate = 50 - 300 rads(Si)/s
 - SEU: Immune up to 120 MeV-cm²/mg
 - SEL: Immune by process design
- Full military temperature range
- Low power consumption < 90mW
- One address bus (A0-3) and three enable lines afford flexible organization
- Fast access time 1500ns typical
- Break-Before-Make switching
- Same *Form / Fit / Function* as ACT8502 minus channel input transorbs
- Designed for aerospace and high reliability space applications
- Packaging – Hermetic ceramic
 - 96 leads, 1.32"Sq x 0.20"Ht quad flat pack
 - Typical Weight 15 grams
- Aeroflex Plainview's Radiation Hardness Assurance Plan is DLA Certified to MIL-PRF-38534, Appendix G.

GENERAL DESCRIPTION

Aeroflex's ACT8506 is a radiation tolerant, 48 channel multiplexer MCM (multi-chip module).

The ACT8506 has been specifically designed to meet exposure to radiation environments. The multiplexer is available in a 96 lead High Temperature Co-Fired Ceramic (HTCC) Quad Flatpack (CQFP). It is guaranteed operational from -55°C to +125°C. Available screened in accordance with MIL-PRF-38534, the ACT8506 is ideal for demanding military and space applications.

ORGANIZATION AND APPLICATION

The ACT8506 consists of six 16 channel multiplexers arranged as shown in the Block Diagram. The ACT8506 design is inherently radiation tolerant.

The ACT8506 consists of forty-eight (48) channels addressable by bus A₀~A₃ in three 16 channel blocks, each block enabled separately. Each block connects the addressed channel to two outputs, "Output" and "Current". This technique enables selecting and reading a remote resistive sensor without the MUX resistance being part of the measurement. For grounded sensors, this is done by passing current to the sensor by means of the "Current" pin and reading the resultant voltage (proportional to the sensor resistance) at the "Output" pin.

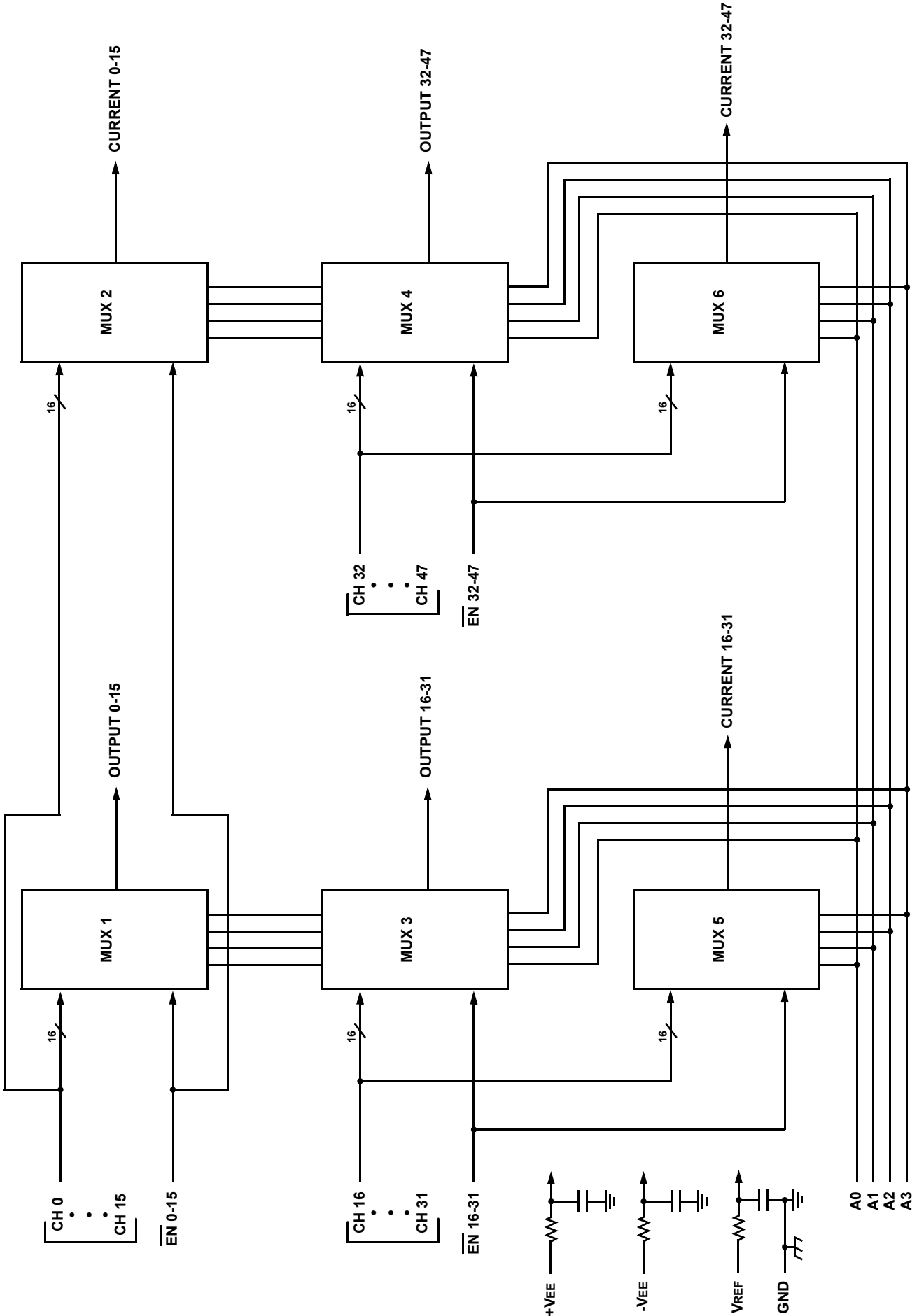

ACT8506 48 – CHANNEL ANALOG MUX BLOCK DIAGRAM

ABSOLUTE MAXIMUM RATINGS ^{1/}

Parameter	Range	Units
Case Operating Temperature Range	-55 to +125	°C
Storage Temperature Range	-55 to +150	°C
Supply Voltage +VEE (Pin 44) -VEE (Pin 46) VREF (Pin 48)	+16.5 -16.5 +16.5	V V V
Digital Input Overvoltage VEN (Pins 5, 91, 92), VA (Pins 1, 3, 93, 95)	<VR +4 >GND -4	V V
Analog Input Over Voltage (Power On/Off) VS	±25	V

Notes:

^{1/} All measurements are made with respect to ground.

NOTICE: Stresses above those listed under "Absolute Maximum Ratings" may cause permanent damage to the device. These are stress rating only; functional operation beyond the "Operation Conditions" is not recommended and extended exposure beyond the "Operation Conditions" may affect device reliability.

RECOMMENDED OPERATING CONDITIONS ^{1/}

Symbol	Parameter	Typical	Units
+VEE	+15V Power Supply Voltage	+15.0	V
-VEE	-15V Power Supply Voltage	-15.0	V
VREF	Reference Voltage	+5.00	V
VAL, VEN	Logic Low Level	+0.8	V
VAH, VEN	Logic High Level	+4.0	V

Notes:

^{1/} Power Supply turn-on sequence shall be as follows: +VEE, -VEE, followed by VREF.

DC ELECTRICAL PERFORMANCE CHARACTERISTICS ^{1/}

(Tc = -55°C to +125°C, +VEE = -15V, -VEE = -15V, VREF = +5.0V - Unless otherwise specified)

Parameter	Symbol	Conditions	Min	Max	Units
Supply Current	+IEE	VEN(0-47) = VA(0-3) = 0	0.3	3	mA
	-IEE		-3	-0.3	mA
	+ISBY	VEN(0-47) = 4V, VA(0-3) = 0 ^{6/}	0.3	3	mA
	-ISBY		-3	-0.3	mA
Address Input Current	I _{AL} (0-3)	VA = 0V ^{1/} , ^{7/}	-6	6	μA
	I _{AH} (0-3)	VA = 5V ^{1/} , ^{7/}	-6	6	μA
Enable Input Current	I _{ENL} (0-15)	VEN(0-15) = 0V ^{7/}	-2	2	μA
	I _{ENH} (0-15)	VEN(0-15) = 5V ^{7/}	-2	2	μA
	I _{ENL} (16-31)	VEN(16-31) = 0V ^{7/}	-2	2	μA
	I _{ENH} (16-31)	VEN(16-31) = 5V ^{7/}	-2	2	μA
	I _{ENL} (32-47)	VEN(32-47) = 0V ^{7/}	-2	2	μA
	I _{ENH} (32-47)	VEN(32-47) = 5V ^{7/}	-2	2	μA

DC ELECTRICAL PERFORMANCE CHARACTERISTICS 1/ (continued)

(Tc = -55°C to +125°C, +VEE = -15V, -VEE = -15V, VREF = +5.0V - Unless otherwise specified)

Parameter	Symbol	Conditions	Min	Max	Units	
Positive Input Leakage Current CH0-CH47	ISOFFOUTPUT	VIN = +10V, VEN = 4V, output and all unused MUX inputs under test = -10V 2/, 3/, 7/	+25°C	-20	+20	nA
	+ISOFFCURRENT			-200	+200	nA
Negative Input Leakage Current CH0-CH47	-ISOFFOUTPUT	VIN = -10V, VEN = 4V, output and all unused MUX inputs under test = +10V 2/, 3/, 7/	+25°C	-20	+20	nA
	-ISOFFCURRENT			-200	+200	nA
Output Leakage Current OUTPUTS (pins 25, 70 & 68)	+IDOFFOUTPUT(0-47)	VOUT = +10V, VEN = 4V, output and all unused MUX inputs under test = -10V 3/, 4/, 7/		-100	+100	nA
	+IDOFFCURRENT(0-47)			-100	+100	nA
Output Leakage Current OUTPUTS (pins 25, 70 & 68)	-IDOFFOUTPUT(0-47)	VOUT = -10V, VEN = 4V, output and all unused MUX inputs under test = +10V 3/, 4/, 7/		-100	+100	nA
	-IDOFFCURRENT(0-47)			-100	+100	nA
Switch ON Resistance OUTPUTS (pins 25, 70 & 68)	RDS(ON)(0-47) _A	VIN = +15V, VEN = 0.8V, IOUT = -1mA 2/, 3/, 5/	500	3000	Ω	
	RDS(ON)(0-47) _B	VIN = +5V, VEN = 0.8V, IOUT = -1mA 2/, 3/, 5/	500	3000	Ω	
	RDS(ON)(0-47) _C	VIN = -5V, VEN = 0.8V, IOUT = +1mA 2/, 3/, 5/	500	3000	Ω	
Switch ON Resistance CURRENTS (pins 26, 67 & 69)	RDS(ON)(0-47) _A	VIN = +15V, VEN = 0.8V, IOUT = -1mA 2/, 3/, 5/	500	3000	Ω	
	RDS(ON)(0-47) _B	VIN = +5V, VEN = 0.8V, IOUT = -1mA 2/, 3/, 5/	500	3000	Ω	
	RDS(ON)(0-47) _C	VIN = -5V, VEN = 0.8V, IOUT = +1mA 2/, 3/, 5/	500	3000	Ω	

Notes:

- 1/ Measure inputs sequentially. Ground all unused inputs of the device under test. VA is the applied input voltage to the address lines A(0-3).
- 2/ VIN is the applied input voltage to the input channels CH0-CH47.
- 3/ VEN is the applied input voltage to the enable lines EN (0-15), EN (16-31) and EN (32-47).
- 4/ VOUT is the applied input voltage to the output lines OUTPUT(0-15), OUTPUT(16-31), OUTPUT(32-47), CURRENT(0-15), CURRENT(16-31) and CURRENT(32-47).
- 5/ Negative current is the current flowing out of each of the MUX pins. Positive current is the current flowing into each MUX pin.
- 6/ If not tested, shall be guaranteed to the specified limits.
- 7/ These parameters for Tc = -55°C are guaranteed by design, characterization, or correlation to other test parameters but not production tested.

SWITCHING CHARACTERISTICS

(Tc = -55°C to +125°C, +VEE = +15V, -VEE = -15V, VREF = +5.0V -- Unless otherwise specified)

Parameter	Symbol	Conditions	Min	Max	Units
Switching Test MUX	t _{AHL}	RL = 10KΩ, CL = 50pF	10	1500	ns
	t _{ALH}	RL = 10KΩ, CL = 50pF Tc = +25°C, +125°C Tc = -55°C	10 10	2000 5000	ns
	t _{ONEN}	RL = 1KΩ, CL = 50pF	10	1500	ns
	t _{OFFEN}		10	1000	ns

TRUTH TABLE (CH0 – CH15)

A3	A2	A1	A0	EN(0-15)	"ON" CHANNEL 1/
X	X	X	X	H	NONE
L	L	L	L	L	CH0
L	L	L	H	L	CH1
L	L	H	L	L	CH2
L	L	H	H	L	CH3
L	H	L	L	L	CH4
L	H	L	H	L	CH5
L	H	H	L	L	CH6
L	H	H	H	L	CH7
H	L	L	L	L	CH8
H	L	L	H	L	CH9
H	L	H	L	L	CH10
H	L	H	H	L	CH11
H	H	L	L	L	CH12
H	H	L	H	L	CH13
H	H	H	L	L	CH14
H	H	H	H	L	CH15

1/ Between CH0-15 and OUTPUT (0-15) and CURRENT (0-15).

TRUTH TABLE (CH16 – CH31)

A3	A2	A1	A0	EN(16-31)	"ON" CHANNEL 1/
X	X	X	X	H	NONE
L	L	L	L	L	CH16
L	L	L	H	L	CH17
L	L	H	L	L	CH18
L	L	H	H	L	CH19
L	H	L	L	L	CH20
L	H	L	H	L	CH21
L	H	H	L	L	CH22
L	H	H	H	L	CH23
H	L	L	L	L	CH24
H	L	L	H	L	CH25
H	L	H	L	L	CH26
H	L	H	H	L	CH27
H	H	L	L	L	CH28
H	H	L	H	L	CH29
H	H	H	L	L	CH30
H	H	H	H	L	CH31

1/ Between CH16-31 and OUTPUT (16-31) and CURRENT (16-31).

TRUTH TABLE (CH32 – CH47)

A3	A2	A1	A0	EN(32-47)	"ON" CHANNEL 1/
X	X	X	X	H	NONE
L	L	L	L	L	CH32
L	L	L	H	L	CH33
L	L	H	L	L	CH34
L	L	H	H	L	CH35
L	H	L	L	L	CH36
L	H	L	H	L	CH37
L	H	H	L	L	CH38
L	H	H	H	L	CH39
H	L	L	L	L	CH40
H	L	L	H	L	CH41
H	L	H	L	L	CH42
H	L	H	H	L	CH43
H	H	L	L	L	CH44
H	H	L	H	L	CH45
H	H	H	L	L	CH46
H	H	H	H	L	CH47

1/ Between CH32-47 and OUTPUT (32-47) and CURRENT (32-47)

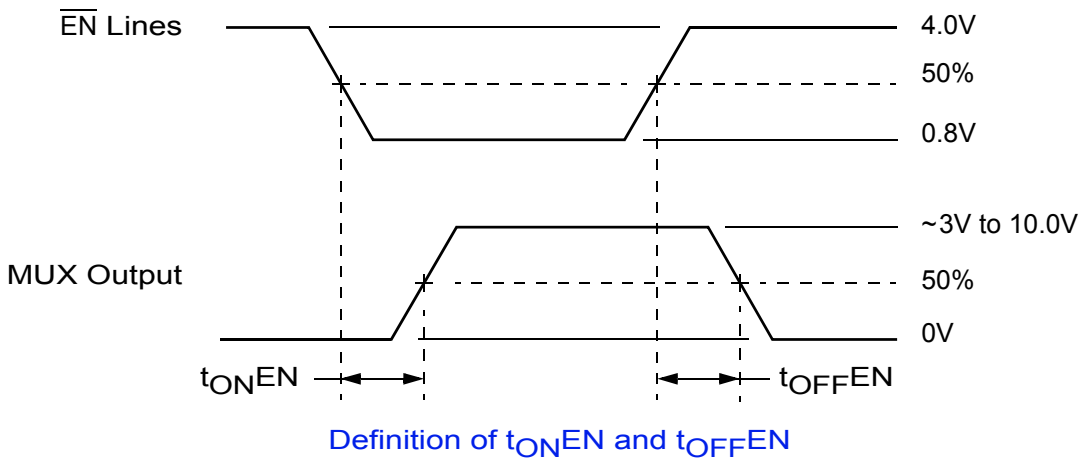
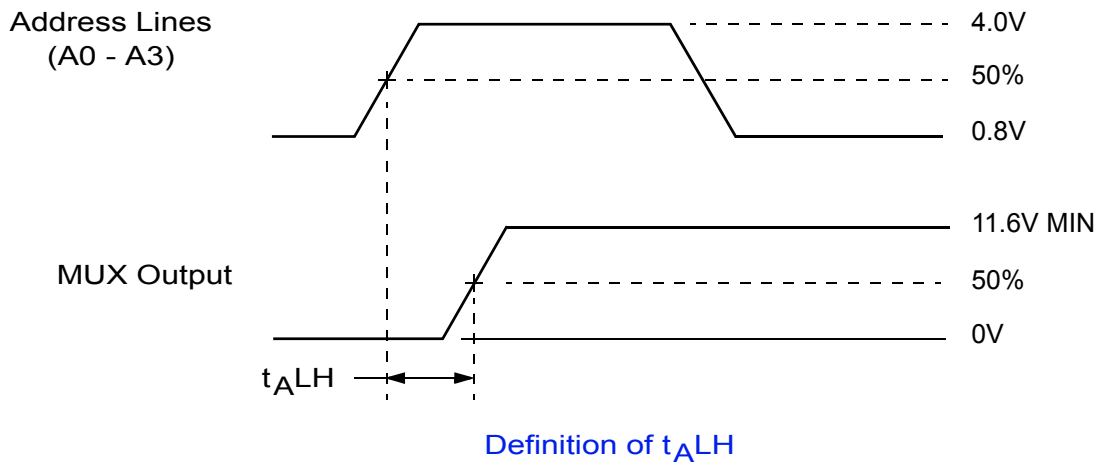
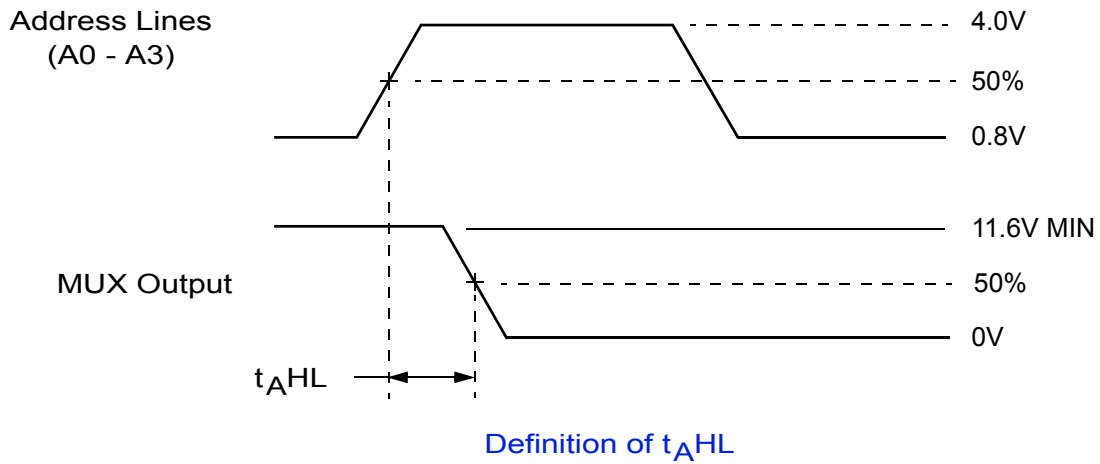

NOTE: $f = 10\text{KHz}$, Duty cycle = 50%.

ACT8506 SWITCHING DIAGRAMS

PIN NUMBERS & FUNCTIONS

ACT8506 – 96 Leads Ceramic QUAD Flat Pack					
Pin #	Function	Pin #	Function	Pin #	Function
1	A2	33	CH11	65	CH33
2	NC	34	NC	66	CH32
3	A3	35	CH12	67	Output I(32-47)
4	NC	36	NC	68	Output V(32-47)
5	$\overline{\text{EN}}$ 0-15	37	CH13	69	Output I(16-31)
6	NC	38	NC	70	Output V(16-31)
7	CH0	39	CH14	71	GND
8	NC	40	NC	72	GND
9	CH1	41	CH15	73	CH31
10	NC	42	NC	74	CH30
11	CH2	43	NC	75	CH29
12	NC	44	+VEE	76	CH28
13	CH3	45	NC	77	CH27
14	NC	46	-VEE	78	CH26
15	CH4	47	NC	79	CH25
16	NC	48	VREF	80	CH24
17	CH5	49	NC	81	CH23
18	NC	50	CASE GND	82	CH22
19	CH6	51	CH47	83	CH21
20	NC	52	CH46	84	CH20
21	CH7	53	CH45	85	CH19
22	NC	54	CH44	86	CH18
23	GND	55	CH43	87	CH17
24	GND	56	CH42	88	CH16
25	Output V(0-15)	57	CH41	89	GND
26	Output I(0-15)	58	CH40	90	GND
27	CH8	59	CH39	91	$\overline{\text{EN}}$ 32-47
28	NC	60	CH38	92	$\overline{\text{EN}}$ 16-31
29	CH9	61	CH37	93	A0
30	NC	62	CH36	94	NC
31	CH10	63	CH35	95	A1
32	NC	64	CH34	96	NC

NOTE: It is recommended that all "NC" or "no connect pin" be grounded. This eliminates or minimizes any ESD or static buildup.

ORDERING INFORMATION

Model Number	DLA SMD #	Screening	Package
ACT8506-7	-	Commercial Flow, +25°C testing only	QUAD Flat Pack
ACT8506-S	5962-0323402KXC	In accordance with DLA SMD	
ACT8506-901-1S	5962F0323402KXC	In accordance with DLA Certified RHA Program Plan to RHA Level "F", 300krads(Si)	

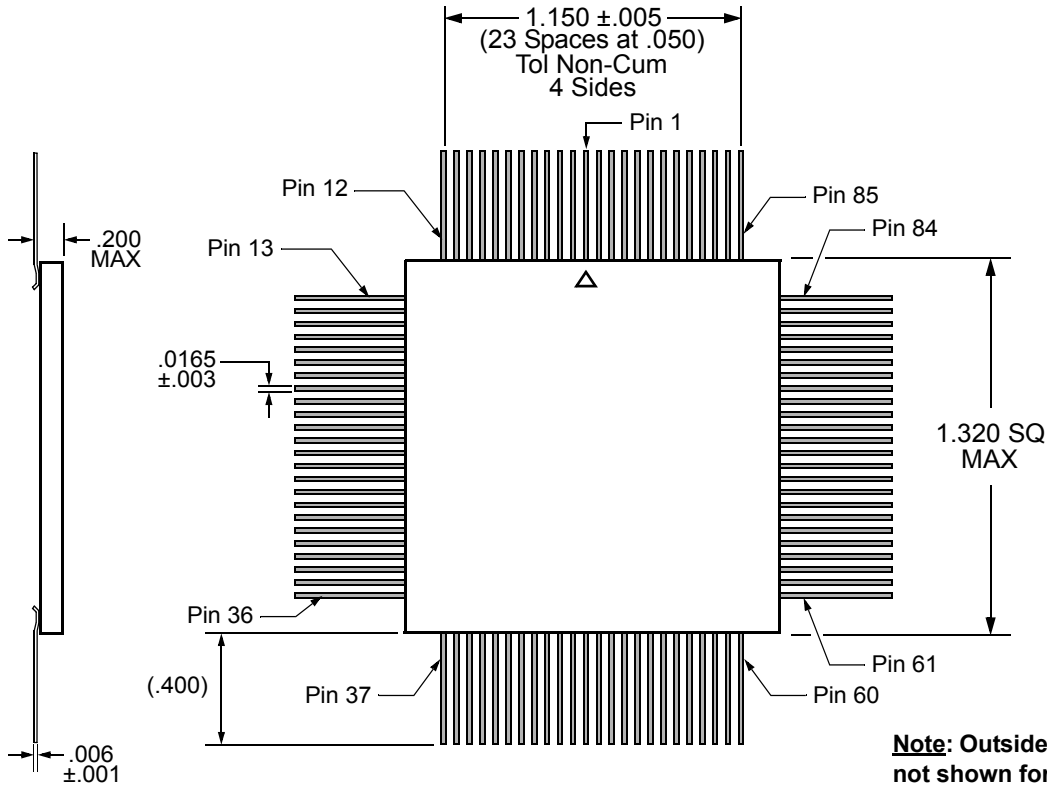

FLAT PACKAGE OUTLINE

EXPORT CONTROL:

This product is controlled for export under the International Traffic in Arms Regulations (ITAR). A license from the U.S. Government is required prior to the export of this product from the United States.

www.aeroflex.com/HiRel info-ams@eroflex.com

Datasheet Definitions:

Advanced Preliminary Datasheet	Product in Development Shipping Non-Flight Prototypes Shipping QML and Reduced HiRel
--------------------------------	--



Aeroflex Plainview, Inc. reserves the right to make changes to any products and services described herein at any time without notice. Consult Aeroflex or an authorized sales representative to verify that the information in this data sheet is current before using this product. Aeroflex does not assume any responsibility or liability arising out of the application or use of any product or service described herein, except as expressly agreed to in writing by Aeroflex; nor does the purchase, lease, or use of a product or service from Aeroflex convey a license under any patent rights, copyrights, trademark rights, or any other of the intellectual rights of Aeroflex or of third parties.

Our passion for performance is defined by three attributes.

