

Standard Products

# ACT8513 48-Channel Analog Multiplexer Module Radiation Tolerant & ESD Protected

[www.aeroflex.com/mux](http://www.aeroflex.com/mux)

November 17, 2008



## FEATURES

- 48 channels provided by three 16-channel multiplexers
- Radiation performance
  - Total dose: 150 krad(Si), Dose rate = 50 - 300 rads(Si)/s
  - SEU: Immune up to 90 MeV-cm<sup>2</sup>/mg
  - SEL: Immune by process design
- Full military temperature range
- Low power consumption < 45mW
- One address bus (A0-3) and three enable lines afford flexible organization
- All channel inputs protected by ±20V nominal transorbs
- Fast access time < 500ns typical
- Break-Before-Make switching
- High analog input impedance (power on or off)
- Designed for aerospace and high reliability space applications
- Packaging – Hermetic ceramic
  - 96 leads, 1.32" Sq x 0.20"Ht quad flat pack
  - Typical Weight 15 grams
- DSCC SMD 5962-09203 pending

*Note: Aeroflex Plainview does not currently have a DSCC certified Radiation Hardened Assurance Program.*

## GENERAL DESCRIPTION

Aeroflex's ACT8513 is a radiation tolerant, 48 channel multiplexer MCM (multi-chip module) with electrostatic discharge (ESD) protection on all channel inputs.

The ACT8513 has been specifically designed to meet exposure to radiation environments. It is available in a 96 lead High Temperature Co-Fired Ceramic (HTCC) Quad Flatpack (CQFP). It is guaranteed operational from -55°C to +125°C. The ACT8513 is ideal for demanding military and space applications.

## ORGANIZATION AND APPLICATION

The ACT8513 consists of three 16 channel multiplexers arranged as shown in the Block Diagram. The Address Bus and three Enable lines provide for 48 channels addressable by bus A<sub>0</sub>-A<sub>3</sub>, in three 16 channel blocks, each block enabled separately. Each block connects the addressed channel to one output.

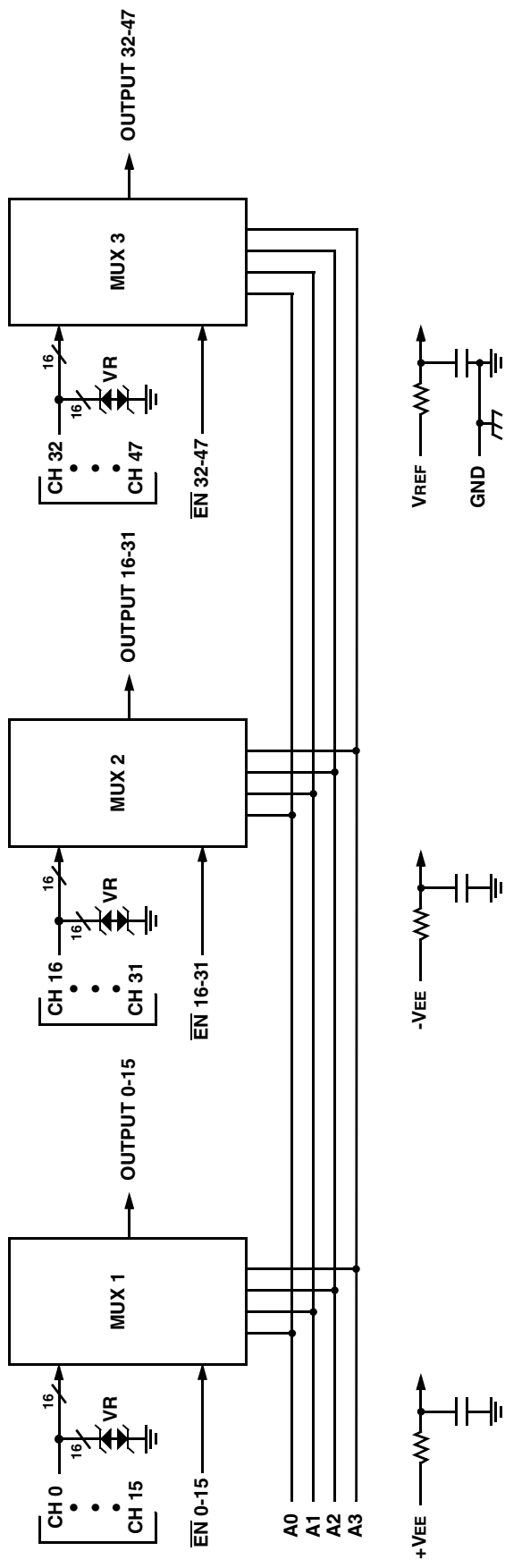

ACT8513 48 – CHANNEL ANALOG MUX BLOCK DIAGRAM

## ABSOLUTE MAXIMUM RATINGS <sup>1/</sup>

Parameter	Range	Units
Case Operating Temperature Range	-55 to +125	°C
Storage Temperature Range	-65 to +150	°C
Supply Voltage +VEE (Pin 44) -VEE (Pin 46) VREF (Pin 48)	+20 -20 +7.5	V V V
Digital Input Overvoltage VEN (Pins 5, 91, 92), VA (Pins 1, 3, 93, 95)	< VREF +0.5 > GND -0.5	V V
Analog Input Over Voltage VS	±18V	V

Notes:

<sup>1/</sup> All measurements are made with respect to ground.

NOTICE: Stresses above those listed under "Absolute Maximums Rating" may cause permanent damage to the device. These are stress rating only; functional operation beyond the "Operation Conditions" is not recommended and extended exposure beyond the "Operation Conditions" may affect device reliability.

## RECOMMENDED OPERATING CONDITIONS <sup>1/</sup>

Symbol	Parameter	Typical	Units
+VEE	+15V Power Supply Voltage	+15.0	V
-VEE	-15V Power Supply Voltage	-15.0	V
VREF	Reference Voltage	+5.00	V
VAL	Logic Low Level	+0.8	V
VAH	Logic High Level	+4.0	V

Notes:

<sup>1/</sup> Power Supply turn-on sequence shall be as follows: -VEE, VREF, followed by +VEE.

## DC ELECTRICAL PERFORMANCE CHARACTERISTICS <sup>1/</sup>

(Tc = -55°C to +125°C, -VEE = -15V, VREF = +5.0V, +VEE = +15V -- Unless otherwise specified)

Parameter	Symbol	Conditions	Min	Max	Units
Supply Current	+IEE	VEN(0-47) = VA(0-3) = 0	0	1.5	mA
	-IEE		-1.5	0	mA
	+ISBY	VEN(0-47) = 4V, VA(0-3) = 0 <sup>1/</sup>	0	1.5	mA
	-ISBY		-1.5	0	mA
Address Input Current	I <sub>AL</sub> (0-3)	VA = 0V	-3	3	μA
	I <sub>AH</sub> (0-3)	VA = 5V	-3	3	μA
Enable Input Current	I <sub>ENL</sub> (0-15)	VEN(0-15) = 0V	-1	1	μA
	I <sub>ENH</sub> (0-15)	VEN(0-15) = 5V	-1	1	μA
	I <sub>ENL</sub> (16-31)	VEN(16-31) = 0V	-1	1	μA
	I <sub>ENH</sub> (16-31)	VEN(16-31) = 5V	-1	1	μA
	I <sub>ENL</sub> (32-47)	VEN(32-47) = 0V	-1	1	μA
	I <sub>ENH</sub> (32-47)	VEN(32-47) = 5V	-1	1	μA

## DC ELECTRICAL PERFORMANCE CHARACTERISTICS 1/ (continued)

(Tc = -55°C to +125°C, -VEE = -15V, VREF = +5.0V, +VEE = +15V -- Unless otherwise specified)

Parameter	Symbol	Conditions	Min	Max	Units	
Positive Input Leakage Current CH0-CH47	+ISOFFOUTPUT	VIN = +10V, VEN = 4V, output and all unused MUX inputs under test = +10V 2/, 3/	-100	+1000	nA	
	+ISOFFCURRENT		-100	+1000	nA	
Negative Input Leakage Current CH0-CH47	-ISOFFOUTPUT	VIN = -10V, VEN = 4V, output and all unused MUX inputs under test = -10V 2/, 3/	-100	+1000	nA	
	-ISOFFCURRENT		-100	+1000	nA	
Output Leakage Current OUTPUTS (pins 25, 68 & 70)	+IDOFFOUTPUT	VOUT = +10V, VEN = 4V, output and all unused MUX inputs under test = -10V 3/, 4/	-100	+100	nA	
	+IDOFFCURRENT		-100	+100	nA	
Output Leakage Current OUTPUTS (pins 25, 68 & 70)	-IDOFFOUTPUT	VOUT = -10V, VEN = 4V, output and all unused MUX inputs under test = +10V 3/, 4/	-100	+100	nA	
	-IDOFFCURRENT		-100	+100	nA	
Input Clamped Voltage CH0 - CH47	+VCLMP	VEN = 4V, all unused MUX inputs under test are open. 3/	+25°C	18.0	23.0	V
			+125°C	18.0	23.5	V
			-55°C	17.5	22.5	V
Input Clamped Voltage CH0 - CH47	-VCLMP		+25°C	-23.0	-18.0	V
			+125°C	-23.5	-18.0	V
			-55°C	-22.5	-17.5	V
Switch ON Resistance OUTPUTS (pins 25, 26, 68 & 70)  6/	RDS(ON)(0-47) <sub>A</sub>	VIN = +15V, VEN = 0.8V, IOUT = -1mA 2/, 3/, 5/	200	1000	Ω	
	RDS(ON)(0-47) <sub>B</sub>	VIN = +5V, VEN = 0.8V, IOUT = -1mA 2/, 3/, 5/	200	1500	Ω	
	RDS(ON)(0-47) <sub>C</sub>	VIN = -5V, VEN = 0.8V, IOUT = +1mA 2/, 3/, 5/	200	2500	Ω	

**Notes:**

- 1/ Measure inputs sequentially. Ground all unused inputs of the device under test. VA is the applied input voltage to the address lines A(0-3).
- 2/ VIN is the applied input voltage to the input channels CH0-CH47.
- 3/ VEN is the applied input voltage to the enable lines En(0-15), En(16-31) and En(32-47).
- 4/ VOUT is the applied input voltage to the output lines OUTPUT(0-15), OUTPUT(16-31) and OUTPUT(32-47).
- 5/ Negative current is the current flowing out of each of the MUX pins. Positive current is the current flowing into each MUX pin.
- 6/ The ACT8513 cannot be operated with analog inputs from -15 to -5 volts.
- 7/ Not tested, guaranteed to the specified limits.

## SWITCHING CHARACTERISTICS

(Tc = -55°C to +125°C, -VEE = -15V, VREF = +5.0V, +VEE = +15V -- Unless otherwise specified)

Parameter	Symbol	Conditions	Min	Max	Units
Switching Test MUX	t <sub>AHL</sub>	RL = 10KΩ, CL = 50pF	10	1000	ns
	t <sub>ALH</sub>		10	1000	ns
	t <sub>ONEN</sub>	RL = 1KΩ, CL = 50pF	10	1000	ns
	t <sub>OFFEN</sub>		10	1000	ns

### TRUTH TABLE (CH0 – CH15)

A3	A2	A1	A0	EN(0-15)	"ON" CHANNEL 1/
X	X	X	X	H	NONE
L	L	L	L	L	CH0
L	L	L	H	L	CH1
L	L	H	L	L	CH2
L	L	H	H	L	CH3
L	H	L	L	L	CH4
L	H	L	H	L	CH5
L	H	H	L	L	CH6
L	H	H	H	L	CH7
H	L	L	L	L	CH8
H	L	L	H	L	CH9
H	L	H	L	L	CH10
H	L	H	H	L	CH11
H	H	L	L	L	CH12
H	H	L	H	L	CH13
H	H	H	L	L	CH14
H	H	H	H	L	CH15

1/ Between CH0-15 and OUTPUT (0-15)

### TRUTH TABLE (CH16 – CH31)

A3	A2	A1	A0	EN(16-31)	"ON" CHANNEL 1/
X	X	X	X	H	NONE
L	L	L	L	L	CH16
L	L	L	H	L	CH17
L	L	H	L	L	CH18
L	L	H	H	L	CH19
L	H	L	L	L	CH20
L	H	L	H	L	CH21
L	H	H	L	L	CH22
L	H	H	H	L	CH23
H	L	L	L	L	CH24
H	L	L	H	L	CH25
H	L	H	L	L	CH26
H	L	H	H	L	CH27
H	H	L	L	L	CH28
H	H	L	H	L	CH29
H	H	H	L	L	CH30
H	H	H	H	L	CH31

1/ Between CH16-31 and OUTPUT (16-31)

### TRUTH TABLE (CH32 – CH47)

A3	A2	A1	A0	EN(32-47)	"ON" CHANNEL 1/
X	X	X	X	H	NONE
L	L	L	L	L	CH32
L	L	L	H	L	CH33
L	L	H	L	L	CH34
L	L	H	H	L	CH35
L	H	L	L	L	CH36
L	H	L	H	L	CH37
L	H	H	L	L	CH38
L	H	H	H	L	CH39
H	L	L	L	L	CH40
H	L	L	H	L	CH41
H	L	H	L	L	CH42
H	L	H	H	L	CH43
H	H	L	L	L	CH44
H	H	L	H	L	CH45
H	H	H	L	L	CH46
H	H	H	H	L	CH47

1/ Between CH32-47 and OUTPUT (32-47)

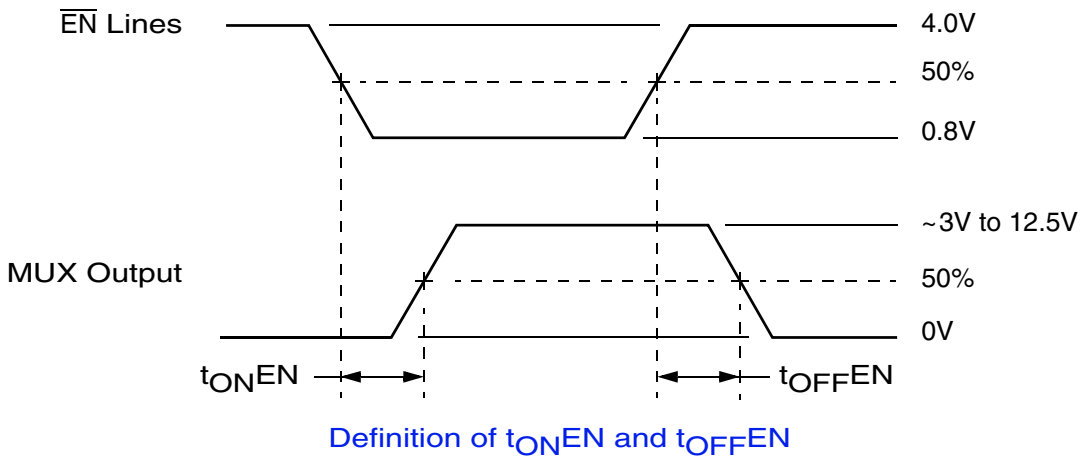
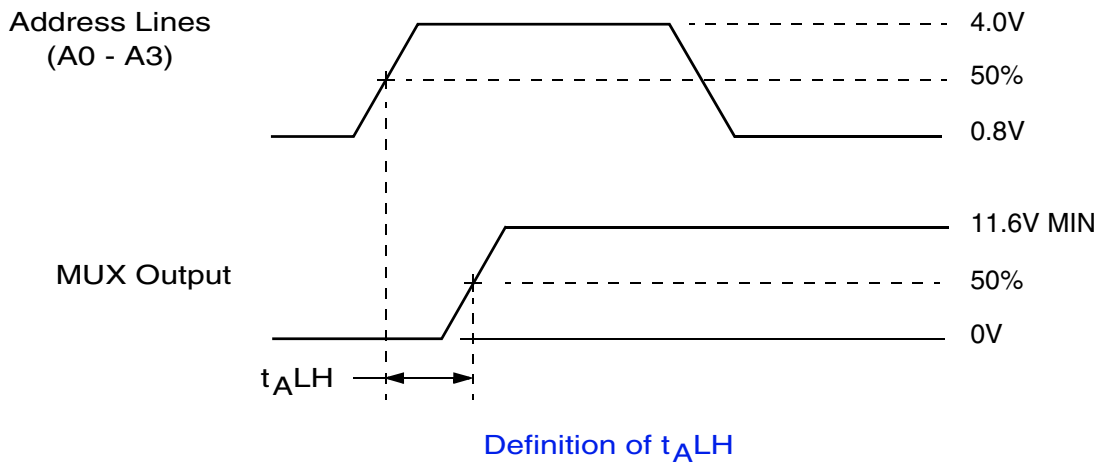
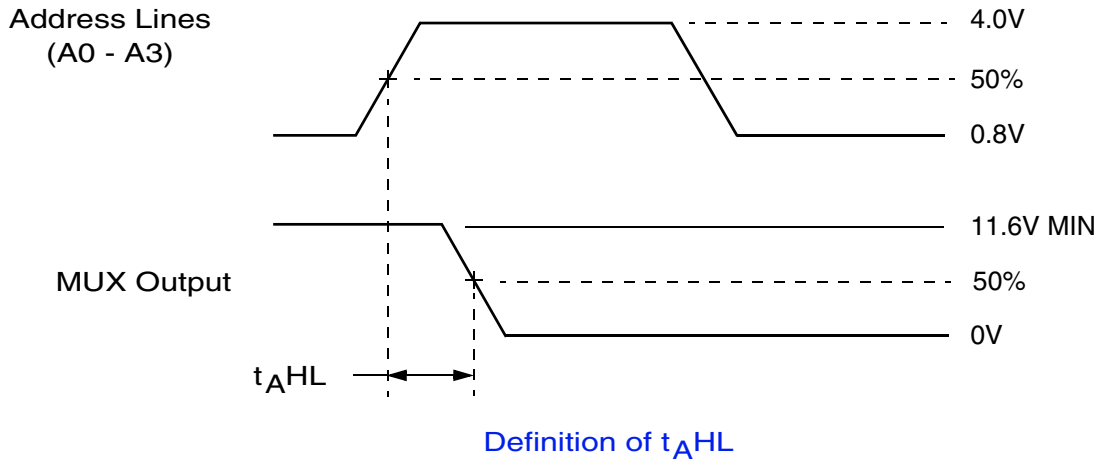

NOTE:  $f = 10\text{KHz}$ , Duty cycle = 50%.

### ACT8512 SWITCHING DIAGRAMS

## PIN NUMBERS & FUNCTIONS

ACT8513 – 96 Leads Ceramic QUAD Flat Pack					
Pin #	Function	Pin #	Function	Pin #	Function
1	A2	33	CH11	65	CH33
2	NC	34	GND	66	CH32
3	A3	35	CH12	67	NC
4	NC	36	GND	68	Output V(32-47)
5	$\overline{\text{EN}}$ 0-15	37	CH13	69	NC
6	NC	38	GND	70	Output V(16-31)
7	CH0	39	CH14	71	GND
8	GND	40	GND	72	GND
9	CH1	41	CH15	73	CH31
10	GND	42	GND	74	CH30
11	CH2	43	NC	75	CH29
12	GND	44	+VEE	76	CH28
13	CH3	45	NC	77	CH27
14	GND	46	-VEE	78	CH26
15	CH4	47	NC	79	CH25
16	GND	48	VREF	80	CH24
17	CH5	49	NC	81	CH23
18	GND	50	CASE GND	82	CH22
19	CH6	51	CH47	83	CH21
20	GND	52	CH46	84	CH20
21	CH7	53	CH45	85	CH19
22	GND	54	CH44	86	CH18
23	GND	55	CH43	87	CH17
24	GND	56	CH42	88	CH16
25	Output V(0-15)	57	CH41	89	GND
26	NC	58	CH40	90	GND
27	CH8	59	CH39	91	$\overline{\text{EN}}$ 32-47
28	GND	60	CH38	92	$\overline{\text{EN}}$ 16-31
29	CH9	61	CH37	93	A0
30	GND	62	CH36	94	NC
31	CH10	63	CH35	95	A1
32	GND	64	CH34	96	NC

NOTE: It is recommended that all "NC" or "no connect pin" be grounded. This eliminates or minimizes any ESD or static buildup.

## ORDERING INFORMATION

Model Number	Screening	DSCC SMD #	Package
ACT8513-S	Military Temperature, -55°C to +125°C, Screened in accordance with MIL-PRF-38534, Class K	NA	QUAD Flat Pack
ACT8513-7	Commercial Flow, +25°C testing only		
ACT8513-201-1S	In accordance with DSCC SMD	5962-0920302KXC	

### FLAT PACKAGE OUTLINE

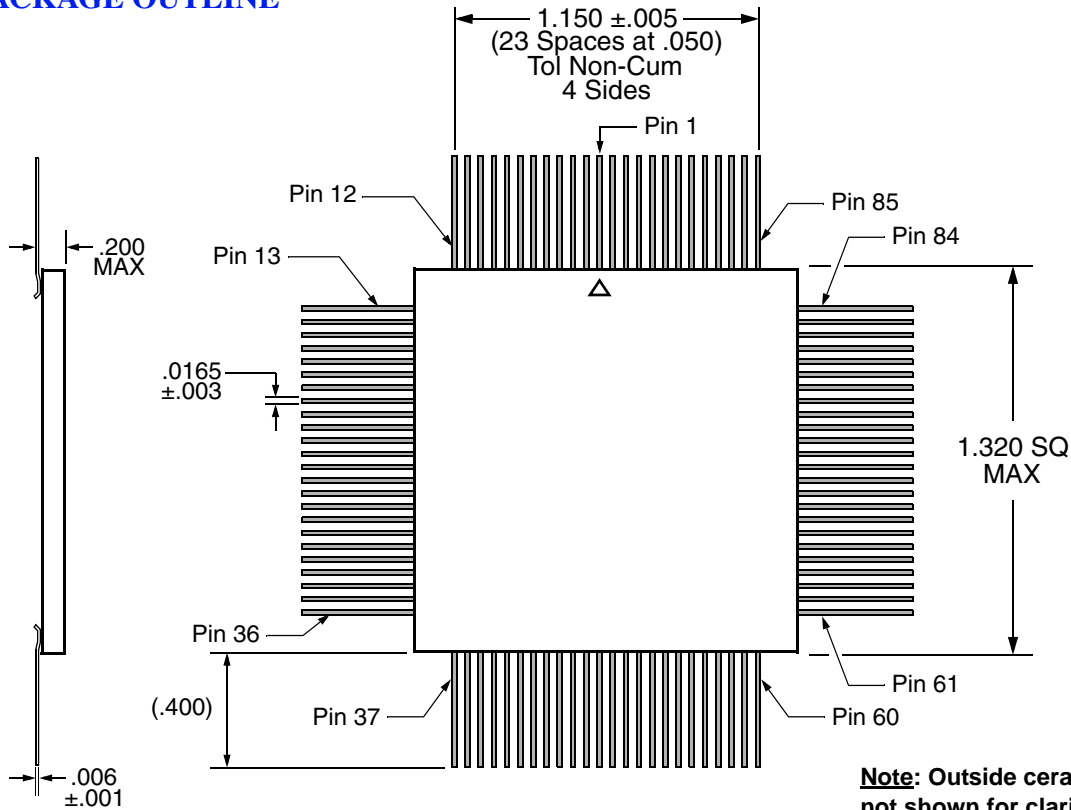

**Note:** Outside ceramic tie bars not shown for clarity. Contact factory for details.

#### EXPORT CONTROL:

This product is controlled for export under the International Traffic in Arms Regulations (ITAR). A license from the U.S. Department of State is required prior to the export of this product from the United States.

#### EXPORT WARNING:

Aeroflex's military and space products are controlled for export under the International Traffic in Arms Regulations (ITAR) and may not be sold or proposed or offered for sale to certain countries. (See ITAR 126.1 for complete information.)

**PLAINVIEW, NEW YORK**  
Toll Free: 800-THE-1553  
Fax: 516-694-6715

**INTERNATIONAL**  
Tel: 805-778-9229  
Fax: 805-778-1980

**NORTHEAST**  
Tel: 603-888-3975  
Fax: 603-888-4585

**SE AND MID-ATLANTIC**  
Tel: 321-951-4164  
Fax: 321-951-4254

**WEST COAST**  
Tel: 949-362-2260  
Fax: 949-362-2266

**CENTRAL**  
Tel: 719-594-8017  
Fax: 719-594-8468

[www.aeroflex.com](http://www.aeroflex.com)    [info-ams@aeroflex.com](mailto:info-ams@aeroflex.com)

Aeroflex Microelectronic Solutions reserves the right to change at any time without notice the specifications, design, function, or form of its products described herein. All parameters must be validated for each customer's application by engineering. No liability is assumed as a result of use of this product. No patent licenses are implied.



Our passion for performance is defined by three attributes represented by these three icons: solution-minded, performance-driven and customer-focused