

## Advanced PMU for Marvell Aspen

### FEATURES

- Optimized for Marvell Aspen Processors
- Three Step-Down DC/DC Converters
- Four Low-Dropout Linear Regulators
- Integrated *ActivePath™* Charger
- I<sup>2</sup>C™ Serial Interface
- Advanced Enable/Disable Sequencing Controller
- Minimal External Components
- Tiny 5x5mm TQFN55-40 Package
  - 0.75mm Package Height
  - Pb-Free and RoHS Compliant

### APPLICATIONS

- Personal Navigation Devices
- Portable Media Players
- Tablet Devices
- Smart Phones
- MIDs

### GENERAL DESCRIPTION

The ACT8938 is a complete, cost effective, highly efficient *ActivePMU™* power management solution, optimized for the unique power, voltage sequencing, and control requirements of the Marvell Aspen processor.

This device features three step-down DC/DC converters and four low-noise, low-dropout linear regulators, along with a complete battery charging solution featuring the advanced *ActivePath™* system-power selection function.

The three DC/DC converters utilize a high efficiency, fixed-frequency (2MHz), current-mode PWM control architecture that requires a minimum number of external components. Two DC/DCs are capable of supplying up to 1150mA of output current, while the third supports up to 1300mA. All four low-dropout linear regulators are high-performance, low-noise, regulators that supply up to 150mA, 150mA, 320mA and 320mA respectively.

The ACT8938 is available in a compact, Pb-Free and RoHS-compliant TQFN55-40 package .

### TYPICAL APPLICATION DIAGRAM

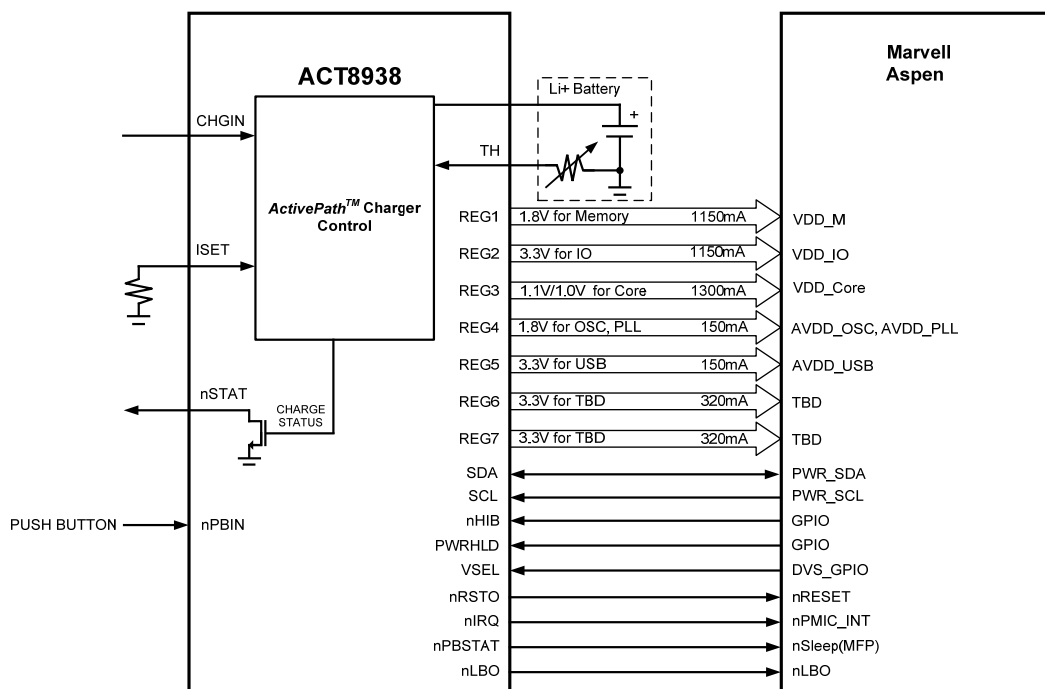

**PRODUCT OPTIONS**

Block	Function	Output Voltage	Capability
ActivePath	System Power Selection	4.6V	Up to 2A
CHGR	Battery Charger	4.2V	Programmable up to 1A
REG1	Step-Down DC/DC	Adjustable, or 0.6V to 3.9V	1150mA
REG2	Step-Down DC/DC		1150mA
REG3	Step-Down DC/DC		1300mA
REG4	LDO	0.6V to 3.9V	150mA
REG5	LDO		150mA
REG6	LDO		320mA
REG7	LDO		320mA

**FUNCTIONAL BLOCK DIAGRAM**

