

7.60cm Reflective Color LCD Module

Description

The ACX709AKN is a 7.60cm diagonal, 320 × 320 dots (102,400 effective pixels) active matrix reflective color TFT-LCD module with a high performance front light unit with touch panel. This panel provides ultra-high reflection ratio with high contrast ratio. These characteristics are realized by a newly developed reflective electrode structure.

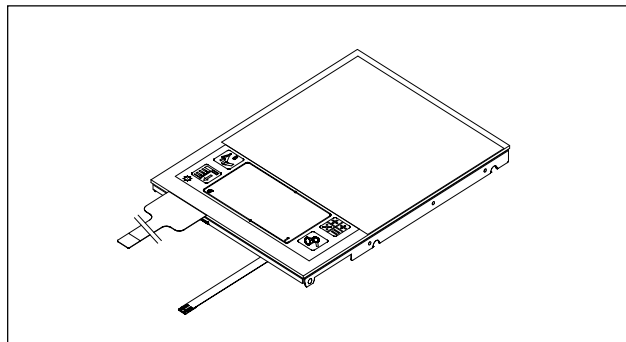

Features

- Number of effective dots: 320 × 320
- Pixel pitch: 168μm × 168μm
- High reflection ratio
- High contrast ratio
- Number of colors: 262,144
- Compact size
- Thin and bright front light unit with touch panel

Element Structure

- Number of dots
Number of active dots: 320 (H) × 320 (V) × 102,400
- Dimensions
Module dimensions: 64.65mm (W) × 87.65mm (D) × 6.0mm (H) (excluding FPC and 凸 area)
Effective display dimensions: 53.76mm (H) × 53.76mm (V)

Applications

PDA, etc.

Sony reserves the right to change products and specifications without prior notice. This information does not convey any license by any implication or otherwise under any patents or other right. Application circuits shown, if any, are typical examples illustrating the operation of the devices. Sony cannot assume responsibility for any problems arising out of the use of these circuits.

Block Diagram

The block diagram of this LCD module is shown below.

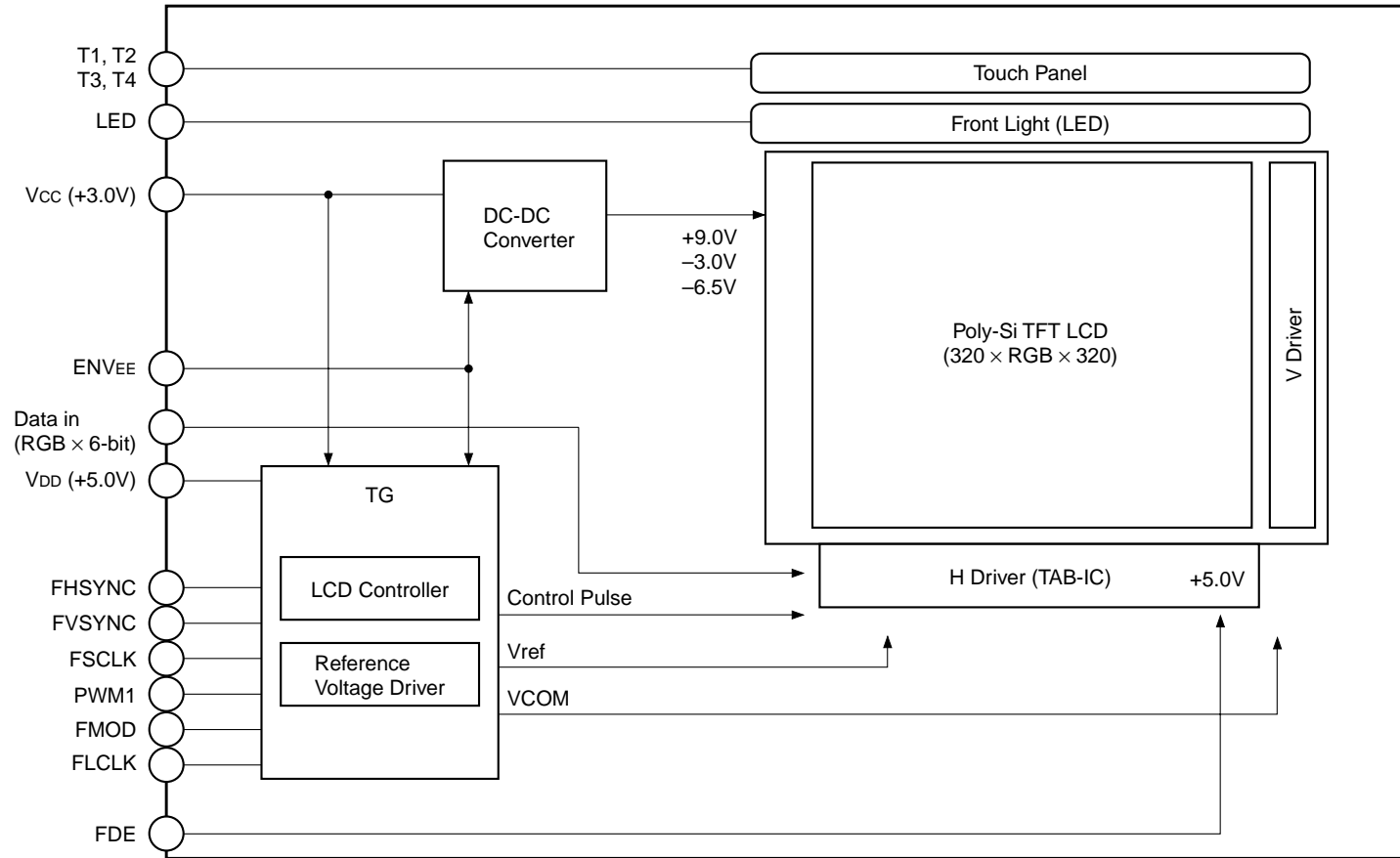

Absolute Maximum Ratings (Ta = 25°C, Vss = 0V)

• Supply voltage	V _{DD}	-0.3 to +6.0	V
	V _{CC}	-0.3 to +4.6	V
• Input voltage	V _I	-0.3 to V _{DD} /V _{CC} + 0.3	V
• Storage temperature	T _{stg}	-20 to +60	°C
• LED current	I _{led}	(as below)	mA

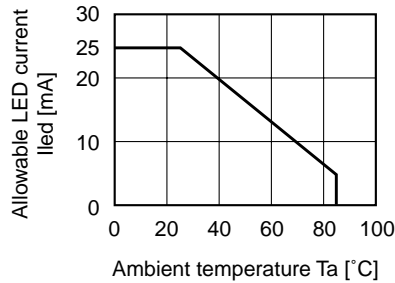

Recommended Operating Conditions

• Supply voltage	V _{DD}	4.7 to 5.3	V
	V _{CC}	2.7 to 3.3	V
• Operating temperature	T _{opr}	0 to +50	°C

Pin Description

Pin No.	Symbol	Description	Pin No.	Symbol	Description
1	V _{DD}	Power supply (+5V)	21	Data30	Data signal
2	V _{DD}	Power supply (+5V)	22	GND	
3	V _{DD}	Power supply (+5V)	23	Data25	Data signal
4	GND		24	Data24	Data signal
5	PWM1	Vertical sampling clock	25	Data23	Data signal
6	ENV _{EE}	Power control pulse	26	Data22	Data signal
7	FMOD	Common plane pulse	27	Data21	Data signal
8	PWM0	Data enable pulse	28	Data20	Data signal
9	FLCLK	Horizontal control pulse	29	GND	
10	FHSYNC	Start signal of horizontal timing	30	Data15	Data signal
11	FVSYNC	Start signal of vertical timing	31	Data14	Data signal
12	GND		32	Data13	Data signal
13	FSCLK	Data sampling clock	33	Data12	Data signal
14	GND		34	Data11	Data signal
15	GND		35	Data10	Data signal
16	Data35	Data signal	36	FDE	Signal control pulse
17	Data34	Data signal	37	GND	
18	Data33	Data signal	38	V _{CC}	Power supply (+3V)
19	Data32	Data signal	39	V _{CC}	Power supply (+3V)
20	Data31	Data signal	40	V _{CC}	Power supply (+3V)

Power Sequence

(1) Power-up Sequence

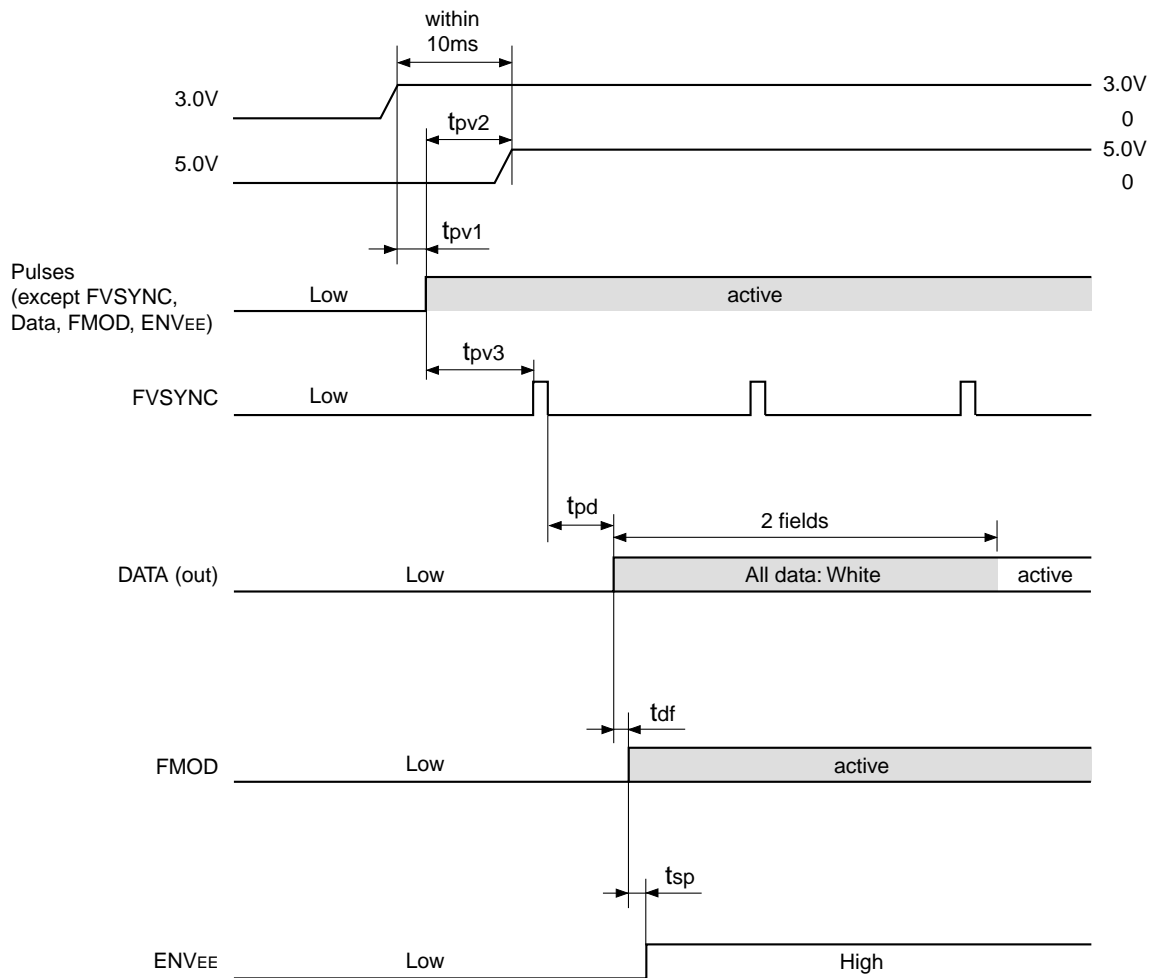

Item	Min.	Typ.	Max.	Unit
$tpv1$	0	—	—	μs
$tpv2$	1	—	—	ms
$tpv1 + tpv2$	—	—	10	ms
$tpv3$	0	—	—	μs
tpd	321PWM1	—	322PWM1	
tdf	0	—	10	μs
tsp	0	—	10	μs

(2) Power-down Sequence

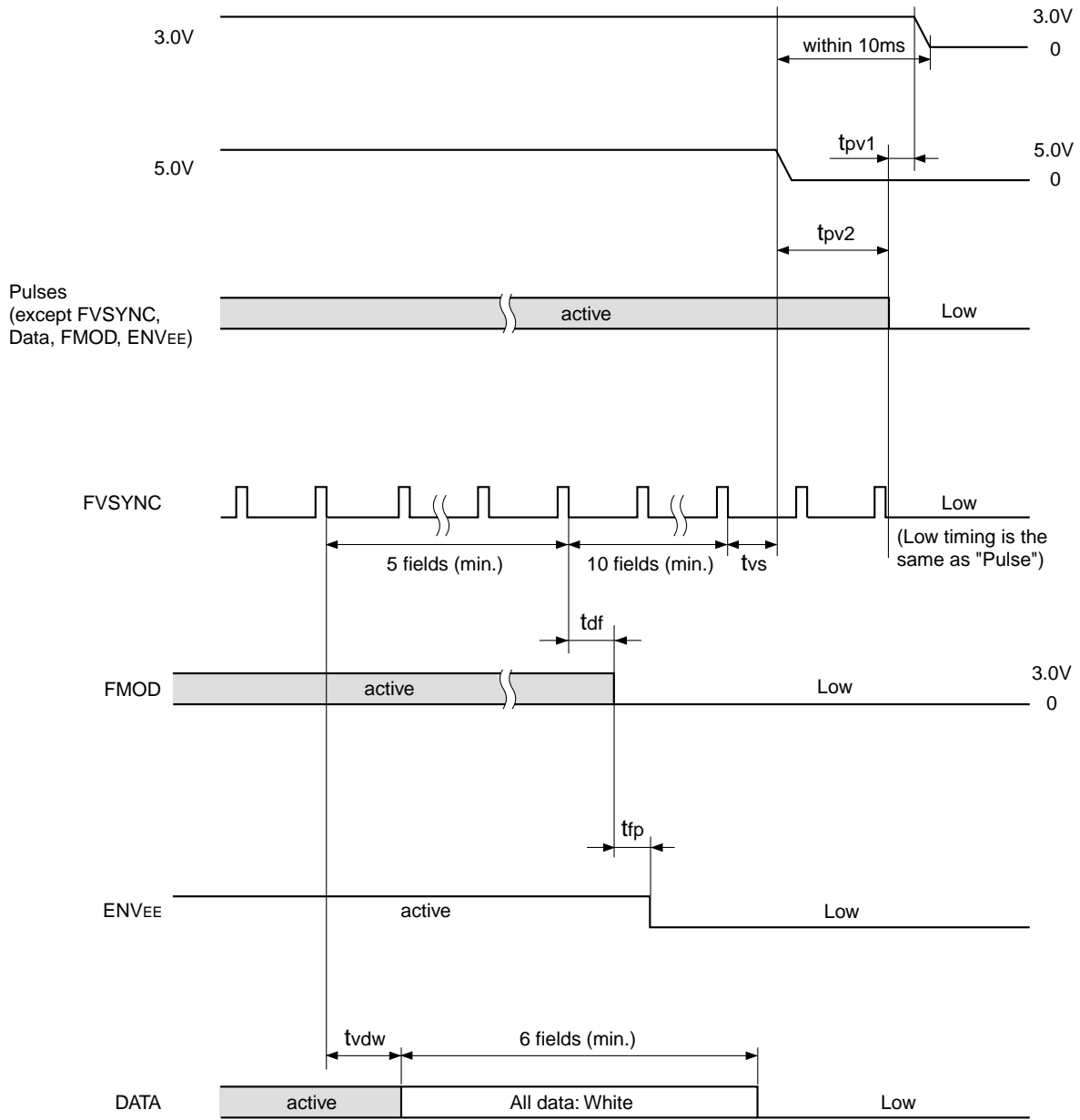

Item	Min.	Typ.	Max.	Unit
tpv1	0	—	—	μ s
tpv2	0	—	—	μ s
tvs	0	—	—	μ s
tvdw	321PWM1	—	322PWM1	
tdf	0	—	10	μ s
tfp	0	—	10	μ s

Electrical Characteristics

(1) Voltage and Current Characteristics

Item	Symbol	Min.	Typ.	Max.	Unit	Pins
Supply voltage	V _{DD}	4.7	5.0	5.3	V	V _{DD}
	V _{CC}	2.7	3.0	3.3	V	
Ripple voltage	V _{rip}	—	—	100	mV	V _{DD}
Input	V _{H1}	0.7V _{CC}	—	—	V	FSCLK (LVTTTL level input)
	V _{L1}	—	—	0.2V _{CC}	V	
Input voltage 2	V _{t+}	—	—	0.75V _{CC}	V	All inputs except for MCK (LVTTTL level Schmitt trigger input)
	V _{t-}	0.15V _{CC}	—	—	V	
	V _{t-} – V _{t+}	0.2			V	
Current consumption	I _{VDD}	—	7.0*1	8.0*2	mA	
	I _{VCC}	—	5.0*1	6.3*2	mA	

*1 V_{CC} = 3.0V/V_{DD} = 5.0V gray scale (16 steps)

*2 V_{CC} = 3.3V/V_{DD} = 3.8V black raster

(2) Timing

Item	Symbol	Min.	Typ.	Max.	Unit
Master clock (MCK)	t _{clk}	—	8.0	10	t _{clk}
DATA setup time	t _{SETUP1}	4	—	—	ns
DATA hold time	t _{HOLD1}	1	—	—	ns
Start pulse setup time	t _{SETUP2}	4	—	—	ns
Start pulse hold time	t _{HOLD2}	1	—	—	ns

(3) Horizontal Timing Chart

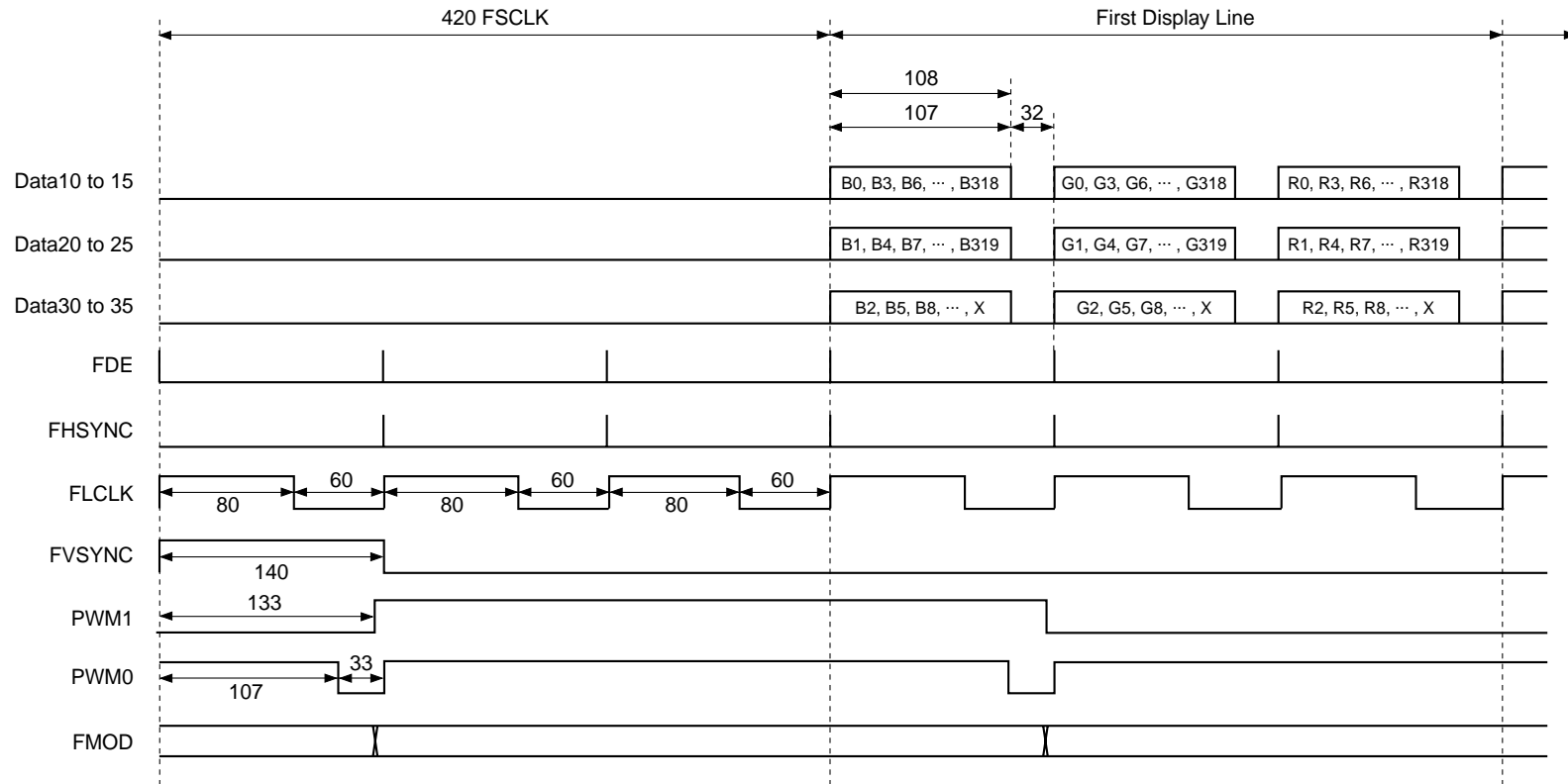

(4) Detail of Horizontal Sequence (Example of B)

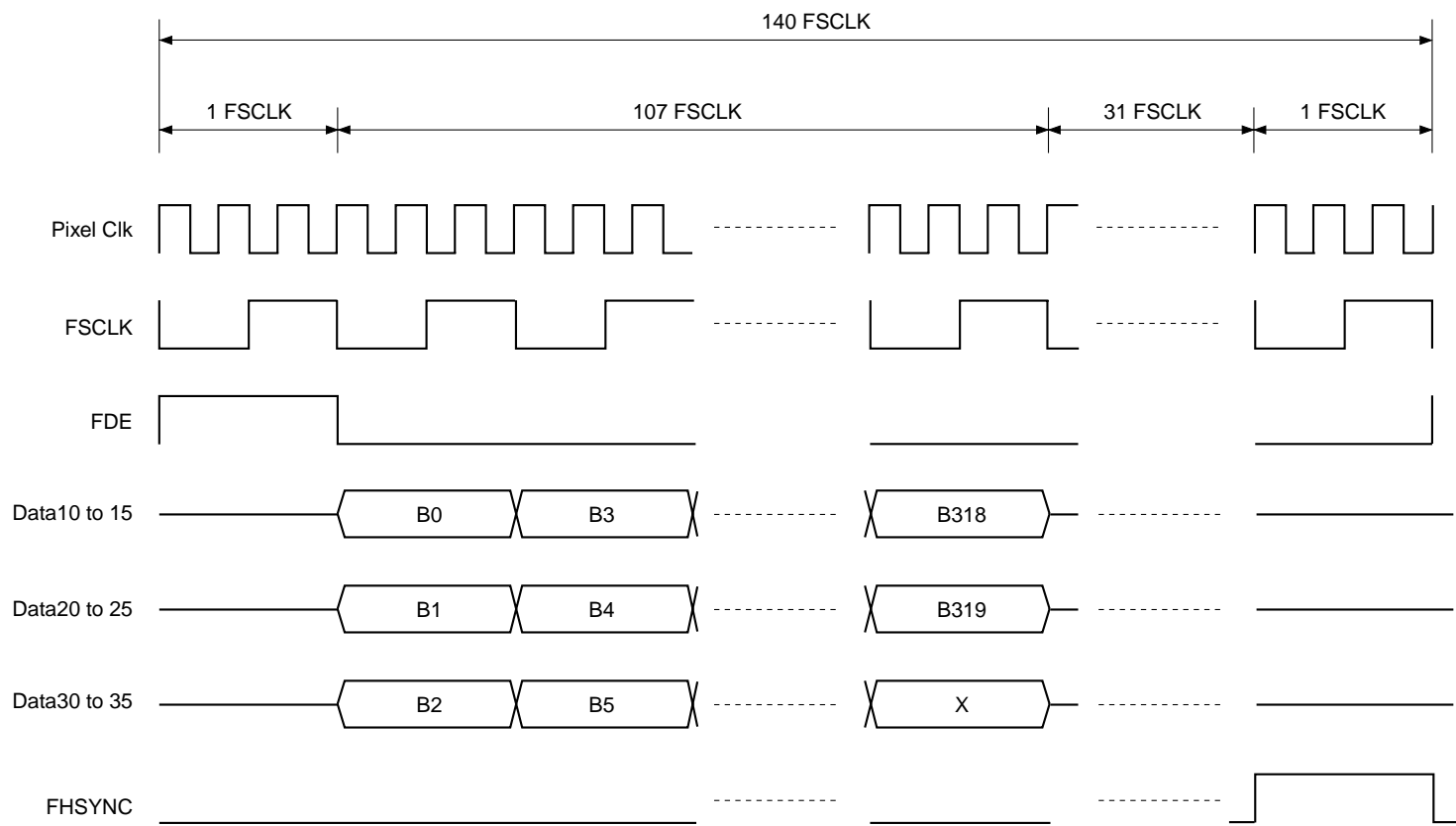

(5) Vertical Timing Chart

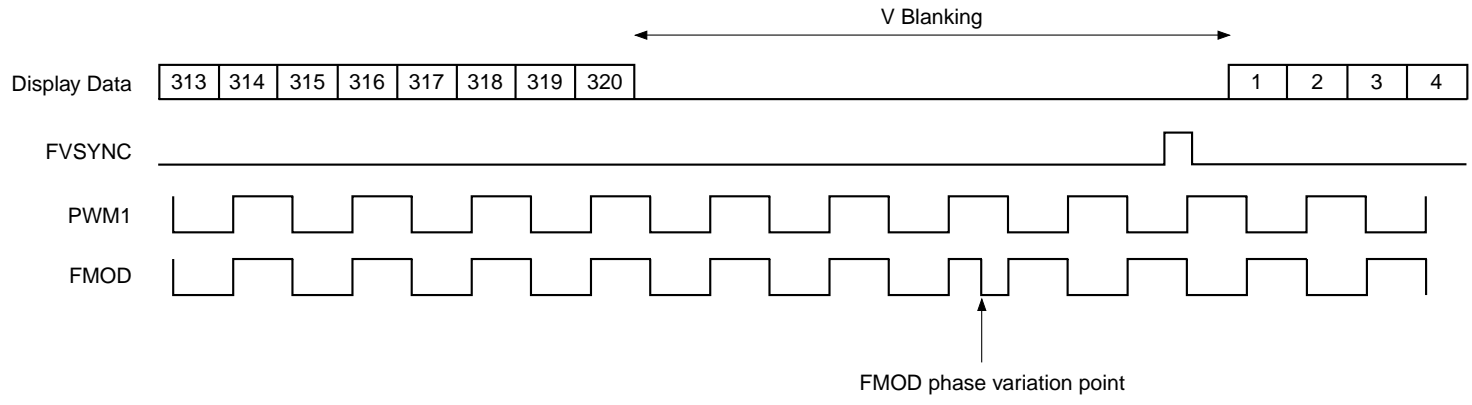

- Notes)**
1. Inversion pulse of PWM1 is not mentioned.
 2. The pulse of FMOD is not prescribed.

(6) Color Table

Colors & Gray scale	Gray scale levels	Data signal																	
		R0	R1	R2	R3	R4	R5	G0	G1	G2	G3	G4	G5	B0	B1	B2	B3	B4	B5
Black	—	0	0	0	0	0	0	0	0	0	0	0	0	0	0	0	0	0	0
Blue	—	0	0	0	0	0	0	0	0	0	0	0	0	1	1	1	1	1	1
Green	—	0	0	0	0	0	0	1	1	1	1	1	1	0	0	0	0	0	0
Cyan	—	0	0	0	0	0	0	1	1	1	1	1	1	1	1	1	1	1	1
Red	—	1	1	1	1	1	1	0	0	0	0	0	0	0	0	0	0	0	0
Magenta	—	1	1	1	1	1	1	0	0	0	0	0	0	1	1	1	1	1	1
Yellow	—	1	1	1	1	1	1	1	1	1	1	1	1	0	0	0	0	0	0
White	—	1	1	1	1	1	1	1	1	1	1	1	1	1	1	1	1	1	1
Black	GS0	0	0	0	0	0	0	0	0	0	0	0	0	0	0	0	0	0	0
↑	GS1	1	0	0	0	0	0	0	0	0	0	0	0	0	0	0	0	0	0
Darker	GS2	0	1	0	0	0	0	0	0	0	0	0	0	0	0	0	0	0	0
↑	↓	↓																	
↓	↓	↓																	
Brighter	GS61	1	0	1	1	1	1	0	0	0	0	0	0	0	0	0	0	0	0
↓	GS62	0	1	1	1	1	1	0	0	0	0	0	0	0	0	0	0	0	0
Red	GS63	1	1	1	1	1	1	0	0	0	0	0	0	0	0	0	0	0	0
Black	GS0	0	0	0	0	0	0	0	0	0	0	0	0	0	0	0	0	0	0
↑	GS1	0	0	0	0	0	0	1	0	0	0	0	0	0	0	0	0	0	0
Darker	GS2	0	0	0	0	0	0	0	1	0	0	0	0	0	0	0	0	0	0
↑	↓	↓																	
↓	↓	↓																	
Brighter	GS61	0	0	0	0	0	0	1	0	1	1	1	1	0	0	0	0	0	0
↓	GS62	0	0	0	0	0	0	0	1	1	1	1	1	0	0	0	0	0	0
Green	GS63	0	0	0	0	0	0	1	1	1	1	1	1	0	0	0	0	0	0
Black	GS0	0	0	0	0	0	0	0	0	0	0	0	0	0	0	0	0	0	0
↑	GS1	0	0	0	0	0	0	0	0	0	0	0	0	1	0	0	0	0	0
Darker	GS2	0	0	0	0	0	0	0	0	0	0	0	0	0	1	0	0	0	0
↑	↓	↓																	
↓	↓	↓																	
Brighter	GS61	0	0	0	0	0	0	0	0	0	0	0	0	1	0	1	1	1	1
↓	GS62	0	0	0	0	0	0	0	0	0	0	0	0	0	1	1	1	1	1
Blue	GS63	0	0	0	0	0	0	0	0	0	0	0	0	1	1	1	1	1	1

(7) Color Coding

The color filters are coded in vertical stripe arrangement.

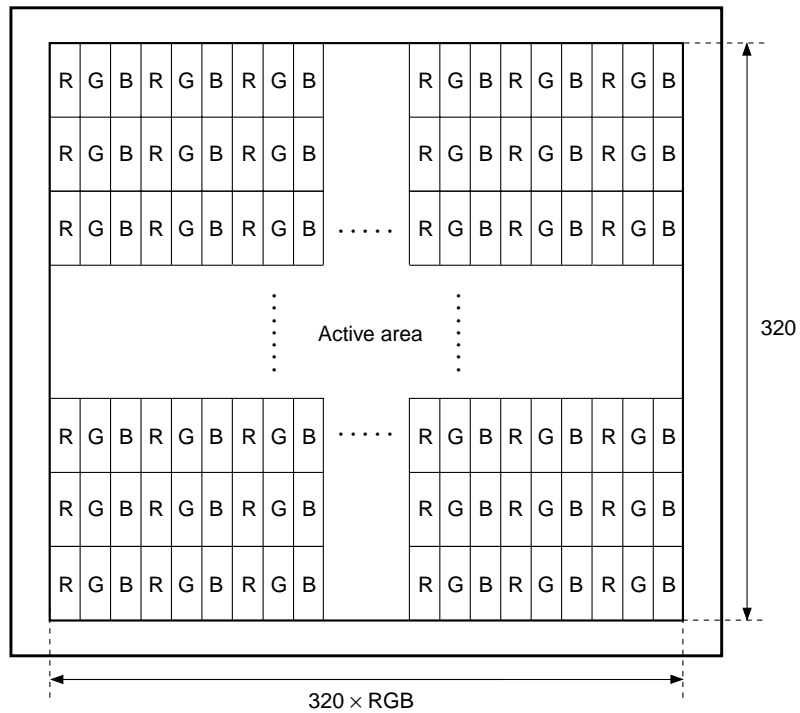

Front View

(8) Scanning Direction

The scanning direction for the horizontal period and for the vertical period are A and B respectively as shown below.

These scanning directions are from a front view.

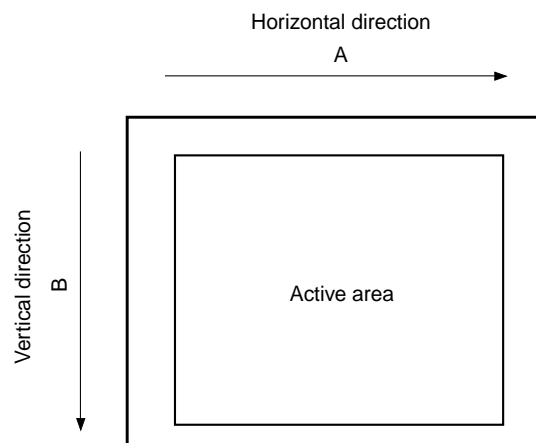

Front View

(9) Touch Panel Electrical Characteristic Specifications

1. Scope

These specifications shall apply to the transparent tablet (for the ACX709AKN).

2. Shape

The shape, structure and dimensions shall be according to the drawings.

3. Ratings

3-1. Maximum voltage

7V

3-2. Operating temperature range

0 to +50°C (discrete tablet state, humidity: 20 to 90%, no condensation)

3-3. Storage temperature range

-20 to +70°C (discrete tablet state, humidity: 20 to 90%, no condensation)

4. Electrical Performance

4-1. Resistance between pins

X direction: 300 to 1000Ω

Y direction: 200 to 1000Ω

4-2. Linearity

X direction: ±1.5% or less

Y direction: ±1.5% or less

* See Separate Sheet 1 for the measurement method.

4-3. Insulation resistance

DC 25V, 20MΩ or more

4-4. Chattering

10ms or less

* See Separate Sheet 2 for the measurement method.

5. Mechanical Performance

5-1. Input method

Dedicated pen or finger

5-2. Operating force

Finger input: 0.8N or less

Pen input: 0.8N or less

* See Separate Sheet 3 for the measurement method.

5-3. Surface hardness

Pencil lead hardness 2H or more (JIS-K5400)

6. Optical Performance

6-1. Ray of light transmittance

83% or more of all rays of light. Surface: clear type

7. Reliability

7-1. High temperature storage

The following items shall be satisfied when measured after storing for 240 hours in a temperature 70°C tank followed by storing at room temperature for 24 hours or more.

- Resistance between pins: Conforms to item 4-1.
- Linearity: Conforms to item 4-2.
- Insulation resistance: Conforms to item 4-3.

7-2. Low temperature storage

The following items shall be satisfied when measured after storing for 240 hours in a temperature –20°C tank followed by storing at room temperature for 24 hours or more.

- Resistance between pins: Conforms to item 4-1.
- Linearity: Conforms to item 4-2.
- Insulation resistance: Conforms to item 4-3.

7-3. High temperature and high humidity storage

The following items shall be satisfied when measured after storing for 240 hours in a 60°C, 90% RH tank followed by storing at room temperature for 24 hours or more.

- Resistance between pins: Conforms to item 4-1.
- Linearity: Conforms to item 4-2.
- Insulation resistance: Conforms to item 4-3.

7-4. Heat shock

The following items shall be satisfied when measured after storing for 10 cycles of –20°C (30 min) → 25°C (1 min or less) → 70°C (30 min) → 25°C (1 min or less), followed by storing at room temperature for 24 hours or more.

- Resistance between pins: Conforms to item 4-1.
- Linearity: Conforms to item 4-2.
- Insulation resistance: Conforms to item 4-3.

8. Durability Performance

8-1. Pen touching life

The following items shall be satisfied after touching one million times with a R0.8 polyacetal pen. Note that the touching load shall be 2.45N and the touching speed shall be 3 times/s.

- Resistance between pins: Conforms to item 4-1.
- Linearity: Conforms to item 4-2.
- Insulation resistance: Conforms to item 4-3.

8-2. Handwriting sliding resistance

The following items shall be satisfied after writing 100,000 characters of the 50 katakana phonograms using the dedicated pen within a 20mm × 20mm frame. Note that the load shall be 2.45N and the speed shall be 3,000 characters/h.

- Resistance between pins: Conforms to item 4-1.
- Linearity: Conforms to item 4-2.
- Insulation resistance: Conforms to item 4-3.

9. Inspection Specifications

9-1. Resistance between pins

Standard: Confirm item 4-1.

The number of inspection: All tablets in the initial state of production. However, shift to sampling inspection after discussions in view of the process capability.

9-2. Linearity

Standard: Confirm item 4-2.

The number of inspection: All tablets in the initial fluid state of production. However, shift to sampling inspection after discussions in view of the process capability.

9-3. Insulation resistance

Standard: Confirm item 4-3.

The number of inspection: All tablets in the initial fluid state of production. However, shift to sampling inspection after discussions in view of the process capability.

9-4. Appearance

Standard: According to the appearance standards.

The number of inspection: All tablets

10. Appearance Standards

10-1. Inspection method

Inspection shall be performed at a distance of 30cm from the eyes by a healthy adult with vision of 1.0 or better (glasses or other vision aids may be used). The fluorescent light shall use two 14W 3-wavelength type.

The background and worktable top shall be black plates, and visual inspection shall be performed at the relative positions shown in the figures below.

Lighting conditions: 1000 lx or less in a bright room

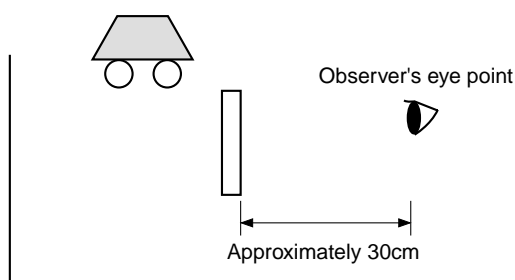

Transmitted light

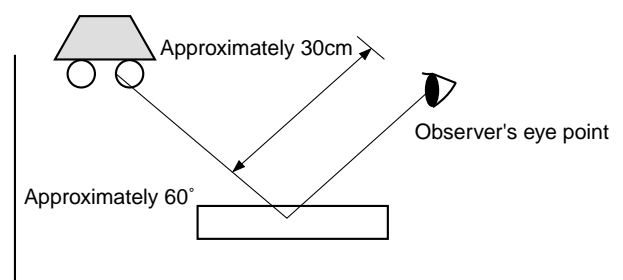

Reflected light

11. Requests on Handling (Be sure to read Separate Sheets 4 and 5 before handling.)

- 11-1. Do not input with anything but your finger or the dedicated pen. Also, do not stack or place heavy objects on the product.
- 11-2. Avoid mechanical shocks, vibration and drops.
- 11-3. Do not expose the product to water, organic solvents or chemical products such as acids or alkalis. Also, do not store the product in these atmospheres.
- 11-4. Hold the edges of the glass when moving the product. Gripping the product inside the effective operation area may cause scratches or dirtiness. Also, avoid handling only the cable or applying excessive force to peripheral circuits, as this may damage the cable and result in disconnection.
- 11-5. If the film surface becomes dirty, wipe it clean using a commercially available eyeglass cleaner or other soft, dry cloth.

12. Notes on Mounting

- 12-1. Do not pull on, apply excessive force to or fold the cable, as this may damage the cable and result in disconnection.
- 12-2. Be careful not to apply an excessive load when mounting the product. Fixing the product with double-sided adhesive tape on the rear surface of the glass is recommended.

[Separate Sheet 1: Linearity Measurement Method]

Definition of Linearity

Apply a DC 5V load between the X direction and Y direction electrodes of the transparent tablet as shown in Fig. 1, and label the voltage between the pressed location and reference surface as the output voltage (Eox, Eoy). Then, measure the output voltage when each intersection of the 10mm lattice enclosed by A and B which are located only a certain distance inside the visible area is pressed as shown in Fig. 2.

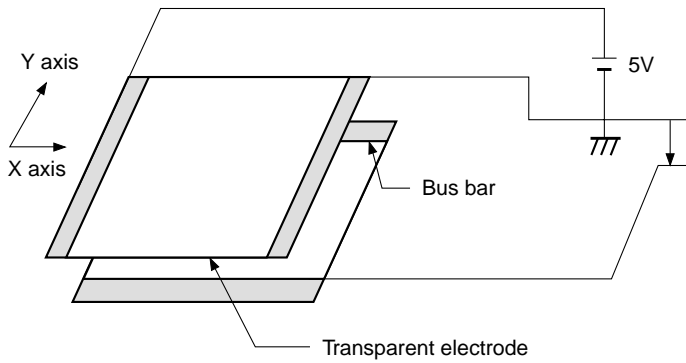

Fig. 1

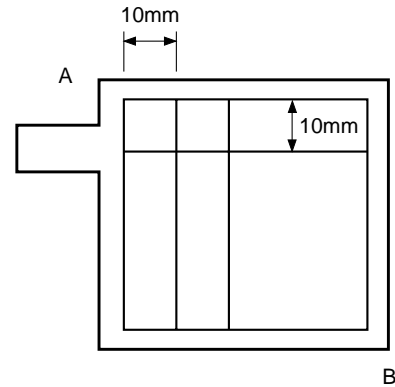

Fig. 2

Plot the output voltage for each measurement position as shown in Fig. 3, and label the difference between the voltage value on the lattice enclosed by A and B and the output voltage at the same position as (ΔE_x , ΔE_y). Linearity is defined as the ratio between (ΔE_x , ΔE_y) and the potential difference between A and B (E_{ABx} , E_{ABy}).

$$\text{Transparent tablet linearity (X)} = (\Delta E_x / E_{ABx}) \times 100\%$$

$$\text{Transparent tablet linearity (Y)} = (\Delta E_y / E_{ABy}) \times 100\%$$

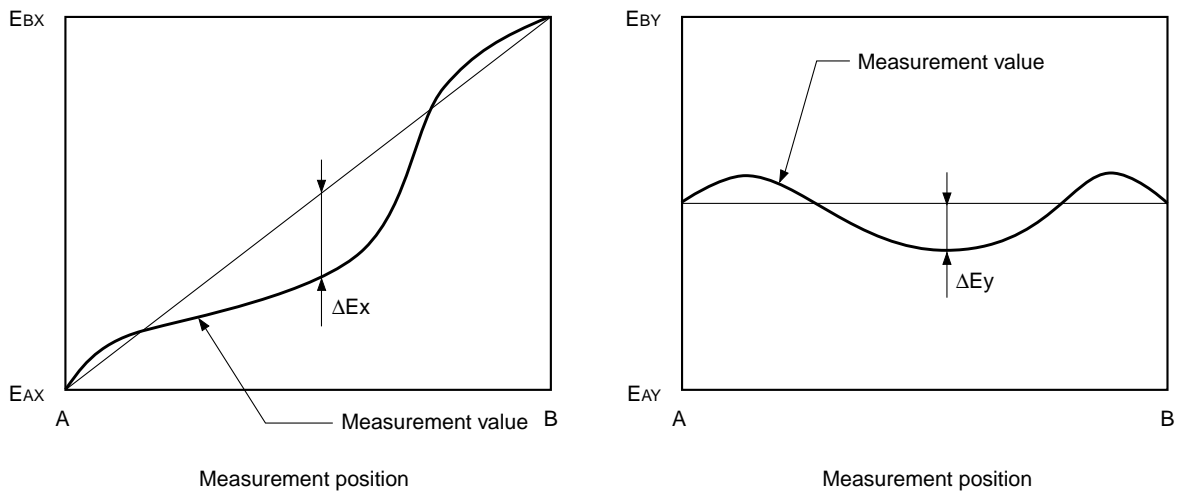

Fig. 3

Linearity Measurement

Connect wiring as shown in Fig. 4, and use the maximum value of the error absolute values when each intersection of the lattice shown in Fig. 5 is pressed as the measurement value.

<Lighting conditions>

- Load: 0.8N
- Measurement tool: 0.8R resin pen
- Measurement locations: Measure at 10mm intervals (6 × 8 points) inside the effective input area of the panel

<Measurement circuit>

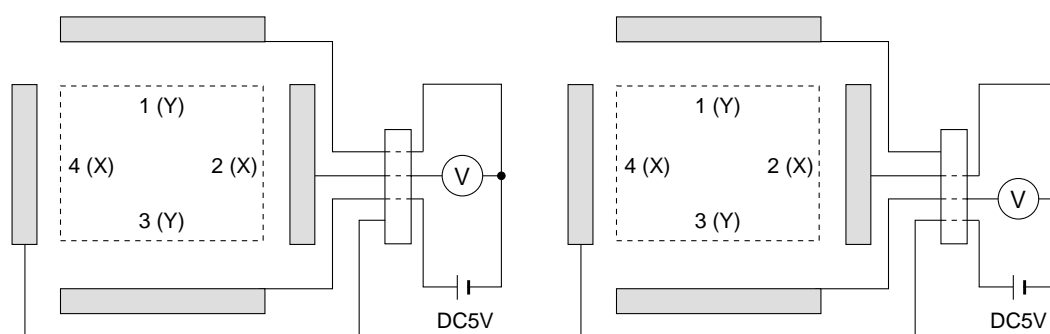

Fig. 4

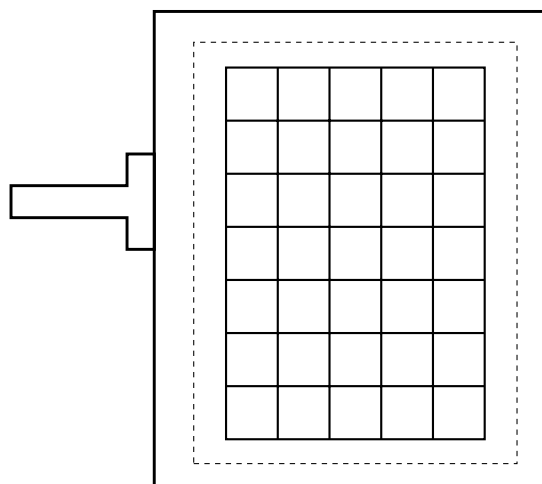

Fig. 5

[Separate Sheet 2: Chattering Measurement Method]

- Measuring equipment: HIOKI 8802 MEMORY Hi CORDER
- Measurement conditions: Measurement voltage: 5V
 Test resistor: 100kΩ
 Switching operation: Holding a R8 silicon rubber rod, perform on and off operation behavior with the same load and speed as normal finger input.

Rise, fall time setting:

Rise: When the switch changes from off to on, the voltage at both ends of the transparent tablet in the measurement circuit shown below follows a curve such as that shown in the chart below. The rise time is the time from 10% to 90% of the stable measurement voltage.

Fall: When the switch changes from on to off, the voltage at both ends of the transparent tablet in the measurement circuit shown below follows a curve such as that shown in the chart below. The fall time is the time from 90% to 10% of the stable measurement voltage.

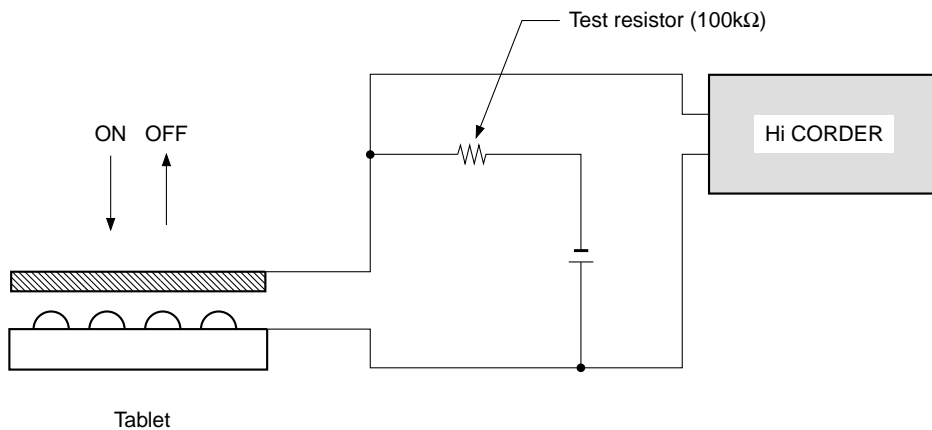

Measurement circuit

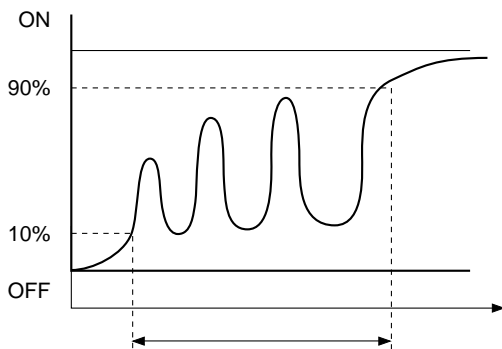

Rise time

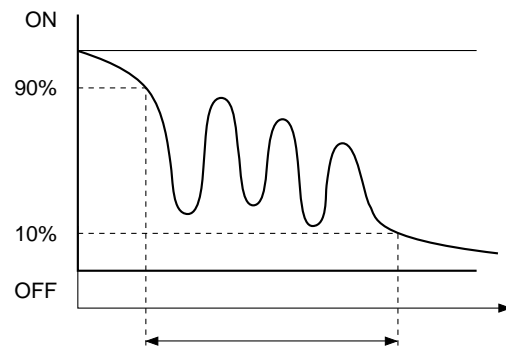

Fall time

[Separate Sheet 3: Operating Force Measurement]

Apply DC 5V to the X side and apply a load with a R8 Hs60° silicon rubber head. The load at which the voltage value stabilizes is the operating force for that point. For pen operation, use a R0.8 Polyacetal pen.

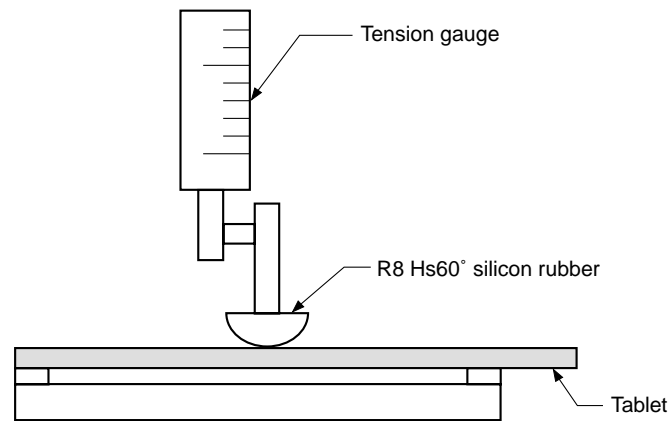
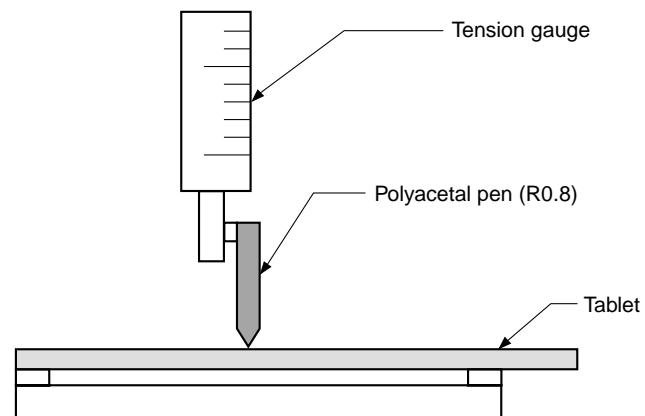
**Finger input measurement****Pen input measurement**

[Separate Sheet 4: Notes on Handling]

This touch panel is designed for use in standard applications (OA and other office equipment, industrial and communications-related equipment, consumer use equipment, etc.). Avoid use in applications where malfunction or misoperation may pose the risk of direct harm to people, or for special applications (aerospace, nuclear power control, medical life support, etc.) which require extremely high reliability.

Touch panel

- a) Do not rub or press on the touch panel with sharp blades or other pointed objects.
- b) Do not excessively fold or bend the touch panel.
- c) When storing the touch panel, use a packing box and store within the recommended storage temperature range. Also make sure that an excessive load is not applied to the touch panel in the stored condition.
- d) Avoid storing or using the touch panel under conditions exposed to water and organic solvents, or in an acidic atmosphere.
- e) Avoid using the touch panel in locations exposed to direct sunlight.
- f) Do not peel apart or disassemble the touch panel.
- g) Do not hold the touch panel by just the tail portion; hold the panel glass itself.
- h) If the touch panel becomes dirty, wipe it clean using a cloth moistened with a neutral detergent or alcohol. Should any chemicals adhere to the touch panel, wipe them off immediately in a manner that does not pose an effect to the human body.
- i) The glass edges are not beveled, so be careful not to cut yourself when handling the touch panel.

Structure

- a) The environmental, mechanical and electrical characteristics and other specifications are guaranteed only for the input area.
- b) Condensation forming inside the touch panel does not indicate a malfunction. Condensation will disappear naturally as the touch panel approaches room temperature, but avoid use in the condition where condensation has formed as this may result in malfunction.

Electrical specifications and software

- a) Contact resistance occurs in the conduction between the upper and lower electrodes, and this contact resistance changes according to the finger or pen pressure. Design the software so that data is loaded after the contact resistance stabilizes.
- b) There are always individual differences in the resistance between pins of analog resistor film type touch panels, and this resistance may also change over time or due to the environment. When designing the software, be sure to provide calibration functions to align the display position with the input position.
- c) Analog resistor film type touch panels have a structure such that when two points are pressed at the same time, a dot is judged to have been input at the center of the line connecting those two points. Therefore, do not compile software that requires two-point input.
- d) When drawing with pen input, the line may be broken when the pen passes over a dot spacer. Therefore, corrective functions should be included in the software.

[Separate Sheet 5: Notes on Mounting]

(1) Bezel tip

Make sure the bezel tip falls between the input area and the transparent area. If the bezel tip extends into the input area, when the bezel is pressed the tip may press on the touch panel and result in input.

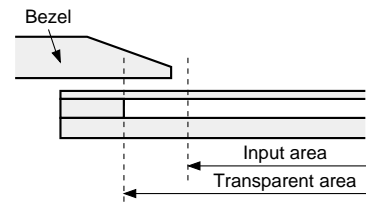

(2) Gap between the bezel and the touch panel

Provide a gap of approximately 0.5mm between the inside of the bezel and top surface of the upper electrode of the touch panel. A narrow gap between the bezel and the upper electrode of the touch panel may result in unanticipated input.

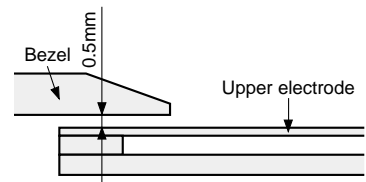

(3) Use of buffer materials

When installing buffer materials between the inside of the bezel and the upper electrode of the touch panel, provide a certain amount of leeway to absorb differences in expansion and contraction between the bezel and the upper electrode due to temperature changes. If the buffer materials are firmly clamped, they may be unable to fully absorb the expansion and contraction, which may cause warping or deflection of the upper electrode of the touch panel, possibly affecting both the appearance and performance of the touch panel.

In addition, be sure to insert the buffer materials to the inside of the insulated area.

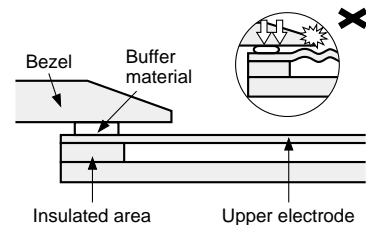

(4) Tolerance

The touch panel and the tail dimensions have tolerances of ± 0.2 to 0.3mm , so be sure to provide leeway of this amount between the case and the connector.

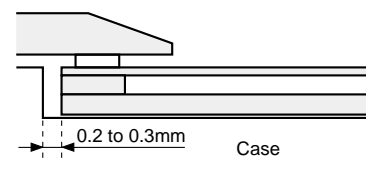

5) Tail bending

Do not use a structure where the tail is strongly clamped, bent sharply at the base, or otherwise subject to stress due to case pressure or other factors. Otherwise, insulation defects or disconnected circuits may result.

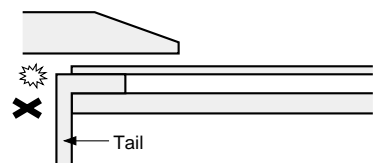

(6) Mounting the touch panel

Be sure to use a structure that supports the touch panel from the bottom such as by adhering the touch panel to the display. If the structure adheres the inside of the bezel to the upper electrode of the touch panel, the joint between the upper and lower electrodes will be subject to stress and easily damaged.

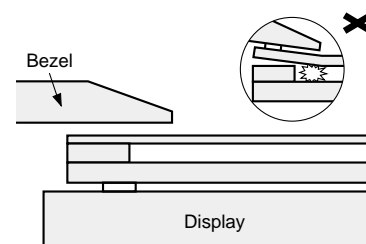

(7) Input prohibited area

The area 2mm to the inside from the insulated area has a structurally weak durability. Particularly if this area is pressed during pen input, the film may stretch and be damaged, so make sure the bezel opening does not extend into this area.

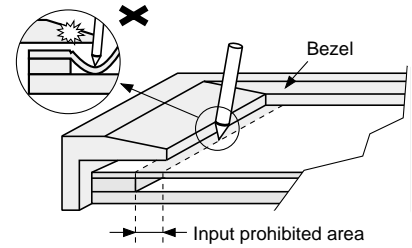
**(8) Ventilation holes**

Some touch panels have ventilation holes to equalize the internal and external air pressure. Be sure not to block these ventilation holes when mounting the touch panel. In addition, moisture accumulating near ventilation holes may seep into the touch panel, so take care to prevent moisture from accumulating. Also avoid situations where pressure from inside the equipment causes the upper film of the touch panel to bulge.

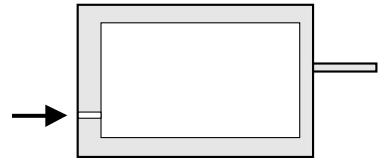

Electro-optical Characteristics

Ta = 25°C, with front light turning off

Item	Symbol	Min.	Typ.	Max.	Unit	Notes	
Reflection ratio	R	15	23	—	%	1	
Contrast ratio	CR	10	13	—		2	
White chromaticity	x	xfloff	0.27	0.320	0.375	CIE	3
	y	yfloff	0.290	0.339	0.390	CIE	
Response time	rise	Tr	—	10	30	ms	4
	fall	Tf	—	15	30	ms	
Viewing angle (CR ≥ 5)	Top-Bottom	θT + B	60	70	—	degree (°)	5
	Left-Right	θR + L	60	70	—	degree (°)	

Ta = 25°C, with front light turning on

(Iled = 15mA × 4 lights (Number in parentheses is a reference value for 20mA))

Item	Symbol	Min.	Typ.	Max.	Unit	Notes
Luminance of active area	Laa	7 (8.4)	9.8 (11.8)	—	cd/m ²	6
Luminance uniformity	Flunif	60	75	—	%	7
White chromaticity	x	0.295	0.350	0.400	—	8
	y	0.285	0.350	0.415	—	
Power consumption	WL	—	216	240	mW	—

Notes:

1. Reflection ratio (R)

In the Measurement System-1 (see Fig. 1 (a), (b)), calculate the reflection ratio by using the formula (1).

$$R = R(\text{White}) = \frac{\text{Output from the "White" displayed panel}}{\text{Output from the reflectance standard}} \dots(1)$$

2. Contrast ratio (CR)

In the Measurement System-1 (see Fig. 1 (a), (b)), measure the reflection ratio of "White" and "Black" respectively and calculate by using the formula (2).

$$CR = \frac{R(\text{White})}{R(\text{Black})} \dots(2)$$

3. White chromaticity

In the Measurement System-2 (see Fig. 2), measure the white chromaticity. The light source and viewing area are D65 and 2° respectively.

4. Response time

In the Measurement System-3 (see Fig. 3), measure the electro-optical response time.

5. Viewing angle

In the Measurement System-1 (see Fig. 1 (c)), viewing area is defined by the area which makes the CR \geq 5.

6. Luminance

In the Measurement System-4 (see Fig. 4), the luminance is defined as follows.

Lcfl = Luminance (5)

7. Luminance uniformity

In the Measurement System-4 (see Fig. 4), measure the luminance and calculate using the following formula.

Flunif = (Luminance (1) + Luminance (2) + ... + Luminance (9))/9

8. White chromaticity with front light turning on.

In the Measurement System-4 (see Fig. 4), measure the white chromaticity.

Basic Measurement Conditions

- (1) Driving voltage
Typical condition
- (2) Measurement temperature
+25°C unless otherwise specified.
- (3) Measurement point
One point on the center of the panel unless otherwise specified.
- (4) Light source and viewing area
D65 and 2°
- (5) Display "White": All R, G and B signal data are (111111).
Display "Black": All R, G and B signal data are (000000).

Front light is turned off unless otherwise specified.

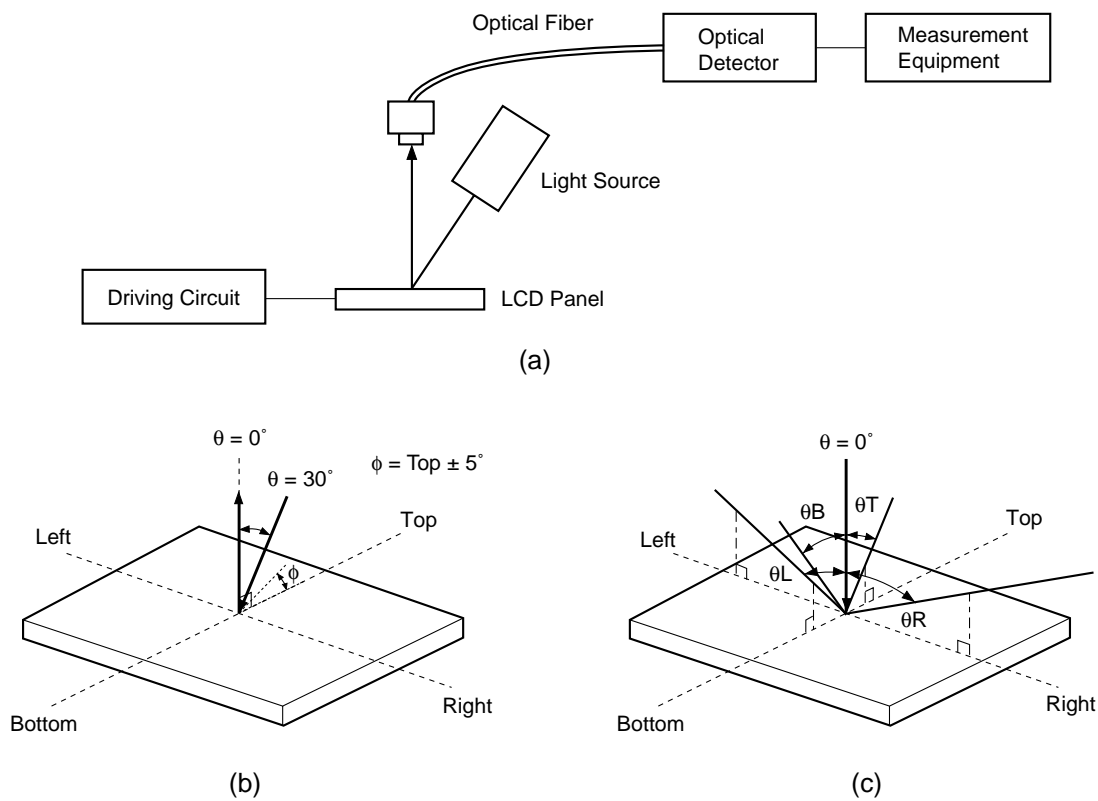

Fig. 1 Measurement System-1

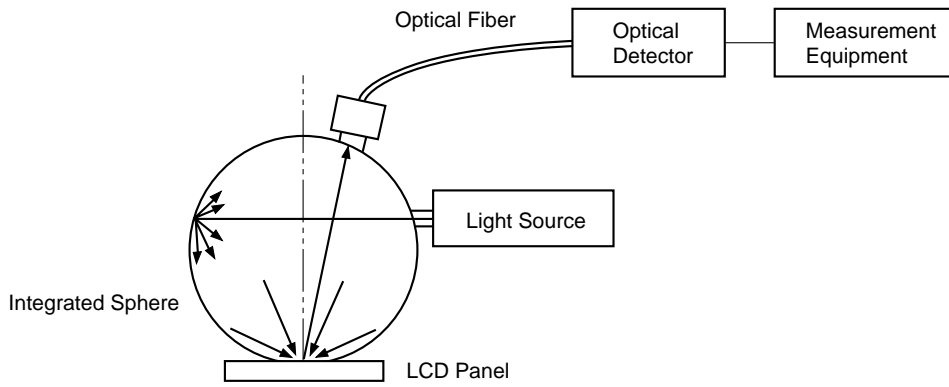

Fig. 2 Measurement System-2

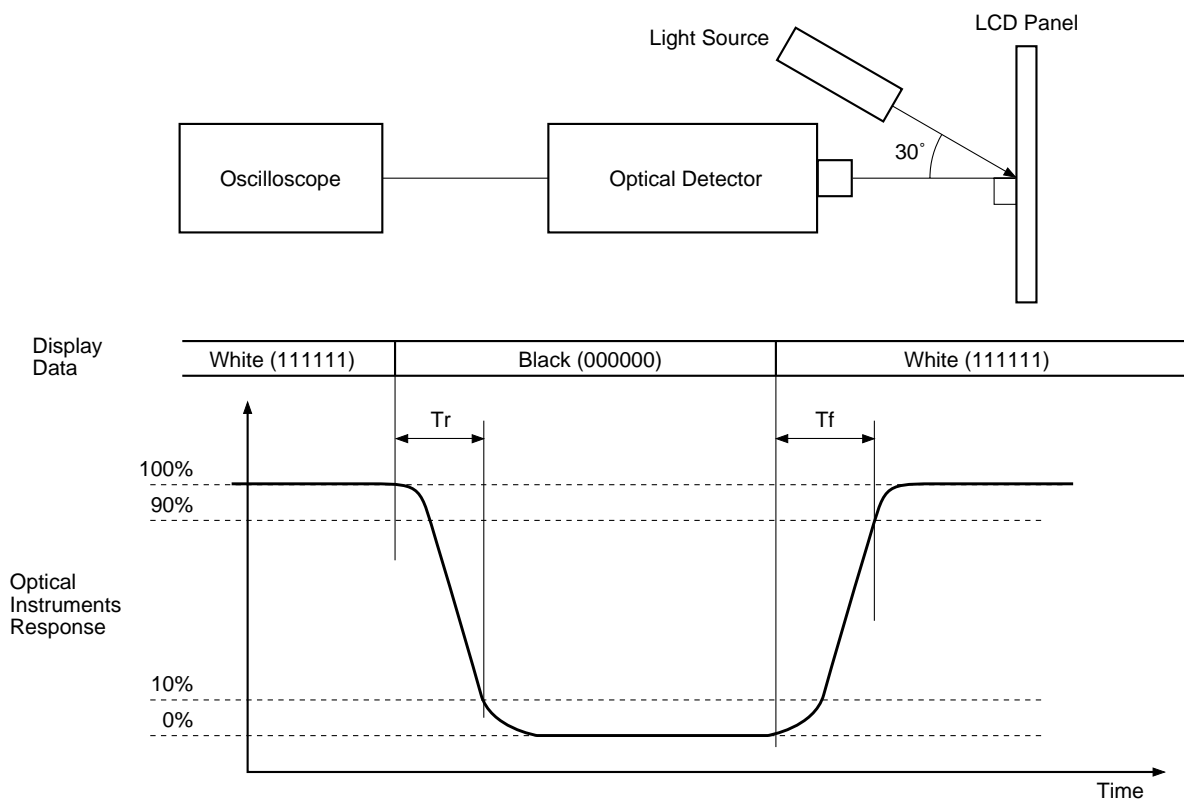
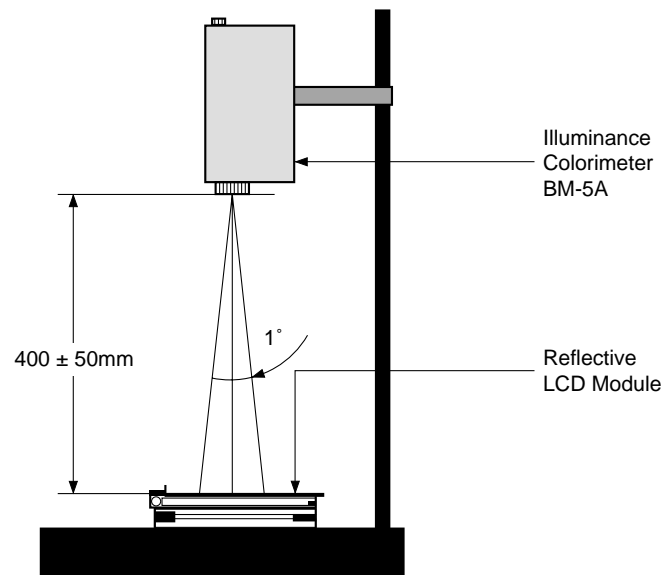
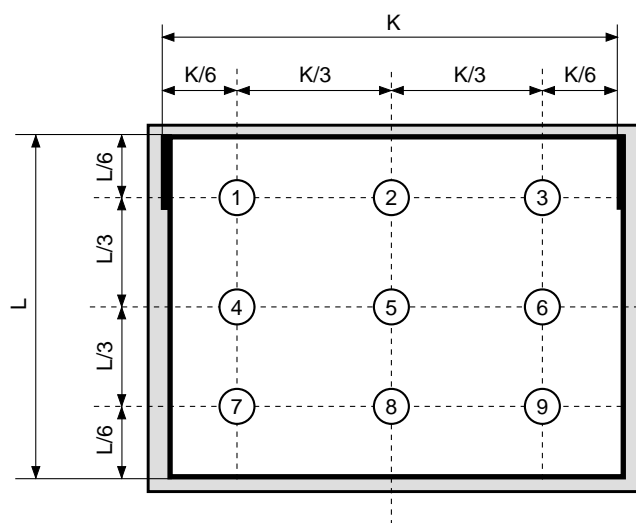

Fig. 3 Measurement System-3



(a) The apparatus for luminance measurement



(b) The spot locations for luminance measurement

Fig. 4 Measurement System-4

Notes on Handling

(1) Static charge prevention

Be sure to take the following protective measures. TFT-LCD modules are easily damaged by static charges.

- a) Use non-chargeable gloves, or simply use bare hands.
- b) Use an earth-band when handling.
- c) Do not touch any electrodes of a module.
- d) Wear non-chargeable clothes and conductive shoes.
- e) Install grounded conductive mats on the working floor and working table.
- f) Keep modules away from any charged materials.
- g) Use ionized air to discharge the modules.

(2) Protection from dust and dirt

- a) Operate in a clean environment.
- b) Use ionized air to blow dust off the module.

(3) Others

- a) Do not touch the surface of any parts of the PWB.
- b) Do not drop the module.
- c) Do not twist or bend the module.
- d) Keep the module away from heat sources.
- e) Do not dampen the module with water or other solvents.
- f) Avoid storage or use of the module at high temperatures or high humidity, as this may result in damage.

Package Outline

Unit: mm

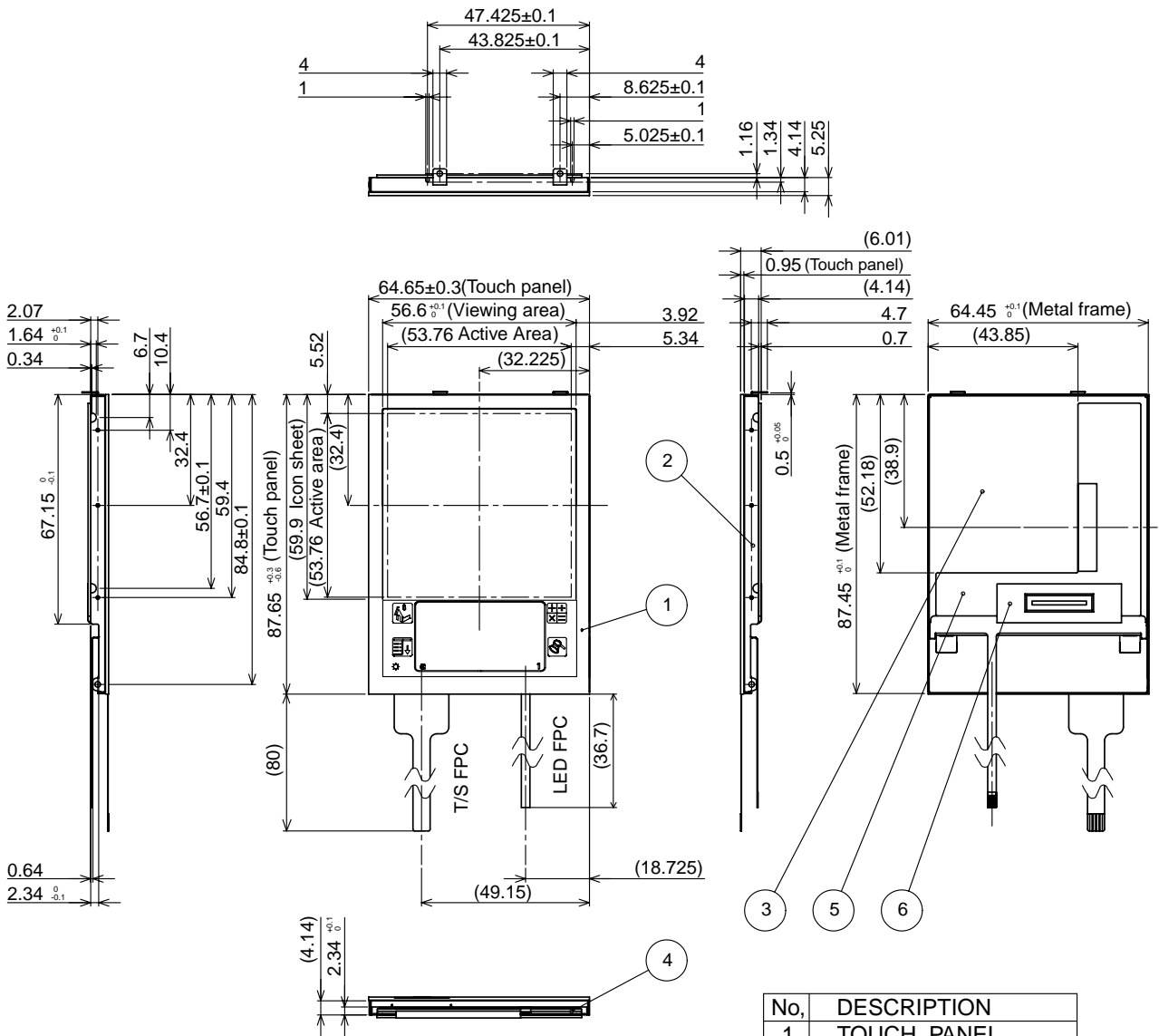

No.	DESCRIPTION
1	TOUCH PANEL
2	FRONT LIGHT
3	FRAME
4	LCD
5	WCB
6	TAB

Note .Tolerance with no indication(±0.2)