

**300V 10A Ultra Low VF Schottky**

**Characteristics Summary**

Characteristics	Values	Units
IF(AV)	5 X 2	A
VRRM	300	V
VF @ 2.5A, TJ = 25°C	0.72	V, typ.
TJ, Operating Junction Temperature	-40 to +150	°C

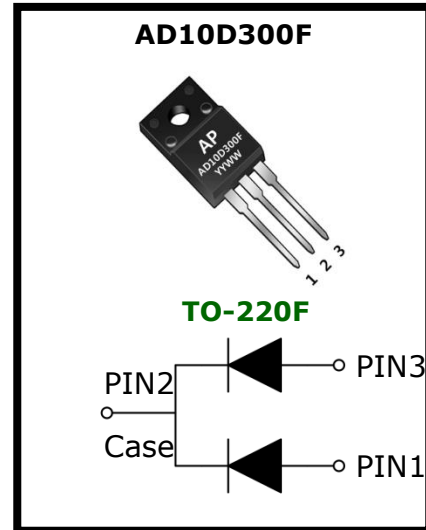

**Features**

- Ultra Low Forward Voltage ( VF ) Drop Low Power Losses
- Low Leakage Current at high temperature.
- Reliable application for various circumstances.
- 150°C Operating Junction Temperature
- Lead Free Finish, RoHS Compliant

**Typical Applications**

Device optimized for low forward voltage drop to maximize efficiency in Power Supply applications, high frequency converters, freewheeling diodes.



## Maximum Ratings Characteristics

( TA = 25°C unless otherwise specified )

Parameter	Symbol	Values	Units
DC Blocking Voltage	V <sub>RM</sub>	300	V
Working Peak Reverse Voltage	V <sub>RWM</sub>		V
Peak Repetitive Reverse Voltage	V <sub>RRM</sub>		V
Average Rectified Forward Current Per device (Rated VR-20Khz Square Wave) – 50% duty cycle	I <sub>D</sub>	5	A
Peak Forward Surge Current – 1/2 60hz	I <sub>FSM</sub>	170	A
Peak Repetitive Reverse Surge Current (2uS-1Khz)	I <sub>RRM</sub>	1	A
Typical Thermal Resistance (per leg) Package = TO-220F	R <sub>θJC</sub>	4	°C / W
Isolation voltage (TO-220F only)	V <sub>AC</sub>	1500	V
Maximum Rate of Voltage Change ( at Rated VR)	dv/dt	10000	V/uS
Operating Junction Temperature	T <sub>J</sub>	-40 to +150	°C
Storage Junction Temperature	T <sub>STG</sub>	-40 to +150	

## Electrical Characteristics – (per leg)

( TA = 25°C unless otherwise specified )

Parameter	Test Conditions		Symbol	Typ.	Max.	Units
Instantaneous Forward Voltage	IF = 2.5 A	T <sub>J</sub> = 25°C	V <sub>F</sub> *	0.72	0.74	V
	IF = 5 A			0.77	0.80	
	IF = 2.5 A	T <sub>J</sub> = 125°C		0.55		
	IF = 5 A			0.65		
Instantaneous Reverse Current	V <sub>R</sub> = 300V	T <sub>J</sub> = 25°C	I <sub>R</sub> *		50	uA
		T <sub>J</sub> = 125°C			10	mA
Junction Capacitance	V <sub>R</sub> = 5V, f = 1MHz		C <sub>J</sub>	150		pF
* Pulse width < 300 uS, Duty cycle < 2%						

## Characteristics Curves

( TA = 25°C unless otherwise specified )

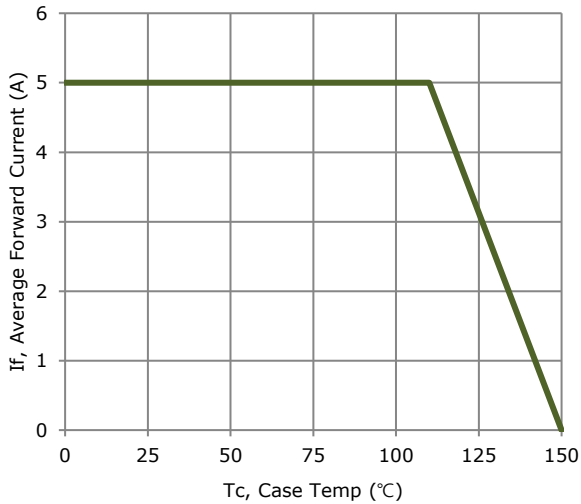

**Figure 1 : Current Derating, Case**

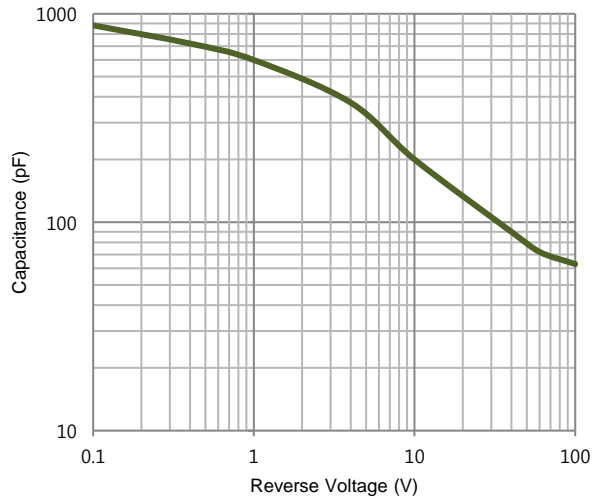

**Figure 2 : Typical Junction Capacitance**

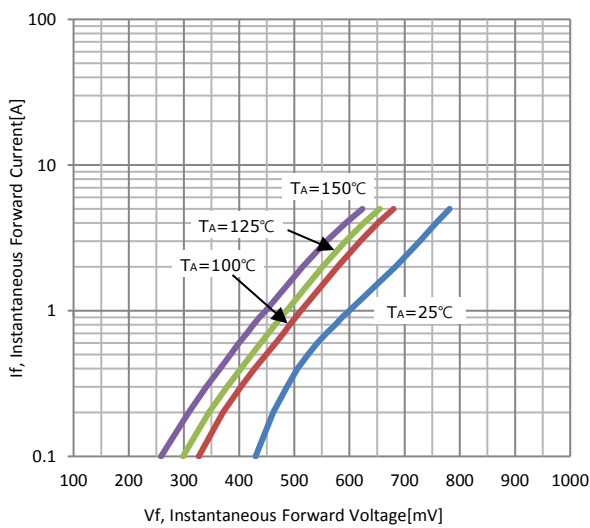

**Figure 3 : Typical Forward Voltage**

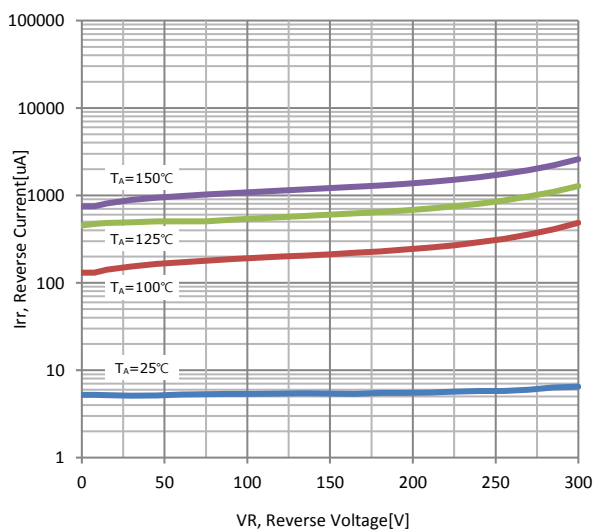

**Figure 4 : Typical Reverse Current**

## Ordering Information

Part No	Package	Packing	Finish	Halogen	Packing Unit
AD10D300F	TO-220F	Tube	Sn	Free	5,000ea

## Marking Layout



**1<sup>ST</sup> Line : Company logo**

**2<sup>nd</sup> Line : Date code**

- **YY : Last two digit of calendar year**
- **WW : Work week calendar**

**3<sup>rd</sup> Line : Device name + PKG CODE**

- **F : TO-220F PKG code**

## Package Dimensions

### TO-220F

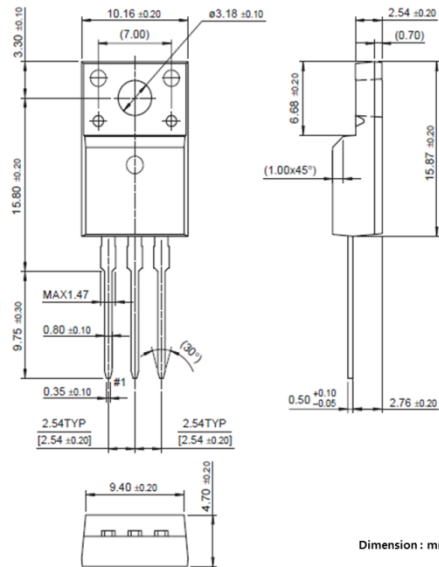

## Revision History

No	Date	Contents
0	2017-04-11	Initial Brief Datasheet Release
1	2019-01-04	Junction Capacitance Updated

<http://www.apsemi.com>

## IMPORTANT NOTICE

AP Semiconductor co, Ltd reserves the right to make changes without further notice to any products or specifications herein. AP Semiconductor co, Ltd does not assume any responsibility for use of any its products for any particular purpose, nor does AP Semiconductor co, Ltd assume any liability arising out of the application or use of any its products or circuits. AP Semiconductor co, Ltd does not convey any license under its patent rights or other rights nor the rights of others.

### AP Semiconductor Co., Ltd

Contact. Tel 82.70.4693.2299 FAX 82.70.4000.4009

E-mail: [sales@apsemi.com](mailto:sales@apsemi.com)

© 2015 AP semiconductor Co., Ltd. -Printed in KOREA -All Rights Reserved.

REV. 01