

FEATURES

Microsoft Vista Premium Logo for notebook

90+ dB audio outputs, 85 dB audio inputs
WLP 3.0 and 4.0

2 stereo headphone amplifiers

Internal 32-bit arithmetic for greater accuracy

Impedance and presence detection on all jacks

Full analog mixer with DAC inputs

3 independent microphone bias pins

Digital and analog PCBeep

3 general-purpose digital I/O (GPIO) pins

3.3 V analog supply voltage

1.7 V to 1.9 V or 3.3 V digital supply voltages

1.5 V or 3.3 V HD Audio link signaling voltage

Advanced power management modes

48-lead, RoHS compliant LFCSP_VQ package

S/PDIF OUTPUT

Supports 44.1 kHz, 48 kHz, 88.2 kHz, 96 kHz, 176.4 kHz, and
192 kHz sample rates

16-, 20-, and 24-bit data; PCM and AC3 formats

Digital PCM gain control

192 kHz DACs/ADCs

2 independent stereo DAC/ADC pairs

Simultaneous record of 2 stereo channels

Simultaneous playback of 2 stereo channels

Independent 8 kHz, 11.025 kHz, 16 kHz, 22.05 kHz, 32 kHz,
44.1 kHz, 48 kHz, 88.2 kHz, 96 kHz, 176.4 kHz, and 192 kHz
sample rates

16-, 20-, and 24-bit resolution

Selectable stereo mixer on outputs

AUXILIARY PINS

Stereo CD/auxiliary I/O port with ground sense

Stereo auxiliary/dock I/O port

Mono out pin for internal speakers or telephony

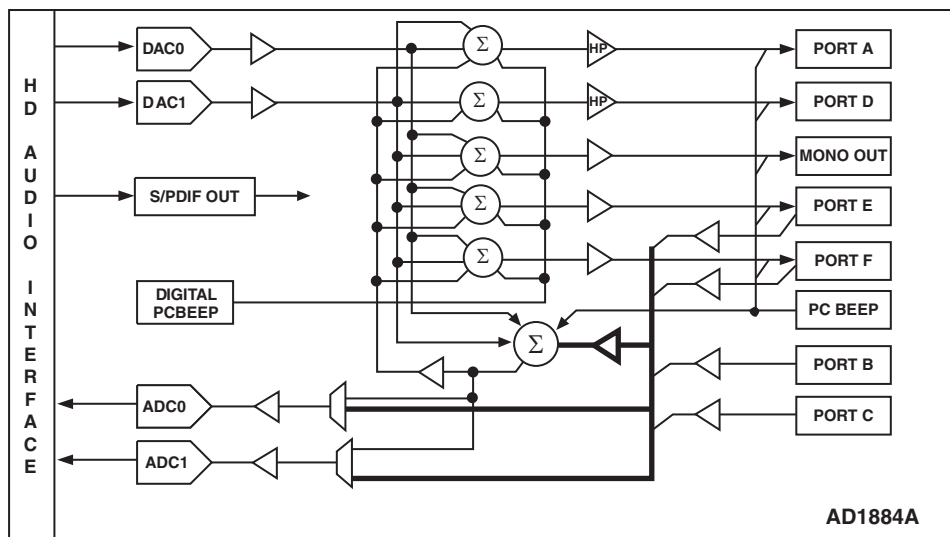

Figure 1. Functional Block Diagram

Rev. 0

Information furnished by Analog Devices is believed to be accurate and reliable. However, no responsibility is assumed by Analog Devices for its use, nor for any infringements of patents or other rights of third parties that may result from its use. Specifications subject to change without notice. No license is granted by implication or otherwise under any patent or patent rights of Analog Devices. Trademarks and registered trademarks are the property of their respective owners.

TABLE OF CONTENTS

| | |
|---|----|
| Features | 1 |
| Revision History | 2 |
| General Description | 3 |
| Additional Information | 3 |
| Jack Configuration | 3 |
| Specifications | 4 |
| Test Conditions | 4 |
| Performance | 4 |
| General Specifications | 4 |
| HD Audio Link Specification | 7 |
| Power-Down States | 7 |
| Absolute Maximum Ratings | 8 |
| ESD Caution | 8 |
| Environmental Conditions | 8 |
| Pin Configuration and Function Descriptions | 9 |
| Audio Widgets | 12 |
| HD Audio Parameters | 13 |
| HD Widget Parameters | 14 |
| Connection List | 15 |
| Default Configuration Bytes | 16 |
| Outline Dimensions | 17 |
| Ordering Guide | 17 |

REVISION HISTORY

3/08—Revision 0: Initial Version

GENERAL DESCRIPTION

The AD1884A audio codec and SoundMAX® software provide superior high definition audio quality that exceeds Vista Premium performance for notebooks. The AD1884A has two 192 kHz DAC pairs, two 192 kHz ADC pairs, an S/PDIF output, and digital and analog PCBeep. These features make the AD1884A the right choice for notebook PCs that meet Microsoft Vista Premium performance as well as desktop PCs that meet Microsoft Vista Basic performance.

The AD1884A is available in a 48-lead, RoHS compliant lead frame chip scale package in both reels and trays. See [Ordering Guide on Page 17](#).

ADDITIONAL INFORMATION

This data sheet provides a general overview of the architecture and functionality of the AD1884A SoundMAX codec. Detailed widget information is available in the AD1884A Programmers Reference Manual. Please contact your local Analog Devices, Inc., sales representative for more information.

JACK CONFIGURATION

The guidelines shown in [Table 1](#) through [Table 3](#) should be used when selecting ports for particular functions.

Table 1. Typical Desktop Configuration

| Port | Function |
|------------|-------------------------------|
| Port A | Front Panel Headphone |
| Port B | Front Panel Microphone |
| Port C | Rear Panel Line-In/Microphone |
| Port D | Rear Panel Line-Out/Headphone |
| S/PDIF Out | Optical/RCA S/PDIF Output |

Table 2. Typical Notebook Configuration

| Port | Function |
|------------|---------------------------|
| Port A | Headphone |
| Port B | Microphone |
| Port C | Internal Microphone |
| Port F | Internal Stereo Speakers |
| S/PDIF Out | Optical/RCA S/PDIF Output |

Table 3. Typical Notebook Configuration with Dock Interface

| Port | Function |
|------------|---------------------------|
| Port A | Headphone |
| Port B | Microphone |
| Port C | Internal Microphone |
| Port D | Dock Line-Out/Headphone |
| Port E | Dock Line-In/Microphone |
| Port F | Internal Stereo Speakers |
| S/PDIF Out | Optical/RCA S/PDIF Output |

AD1884A

SPECIFICATIONS

TEST CONDITIONS

| Parameter | Test Condition |
|------------------------------------|---|
| Temperature | 25°C |
| Digital Supply | 3.3 V |
| Analog Supply | 3.3 V |
| MIC_BIAS_IN (via Low-Pass Filter) | 5.0 V |
| Sample Rate f_s | 48 kHz |
| Input Signal (Frequency Sine Wave) | 1008 Hz |
| Amplitude for THD + N | -3.0 dB Full Scale |
| Analog Output Pass Band | 20 Hz to 20 kHz |
| DAC | 10 k Ω Output Load: Line-Out Tests 32 Ω Output Load: Headphone Tests |
| ADC | 0 dB Gain |

PERFORMANCE

| Parameter | Min | Typ | Max | Unit |
|---|-----|-----|-----|------|
| Line-Out Drive (10 k Ω loads—DAC to Pin) | | | | |
| Total Harmonic Distortion (THD + N) | | -84 | | dB |
| Dynamic Range (-60 dB in ref to f_s A-Weighted) | | 90 | | dB |
| Signal-to-Noise Ratio | | 90 | | dB |
| Headphone Drive (32 Ω loads—DAC to Pin) | | | | |
| Total Harmonic Distortion (THD + N) | | -74 | | dB |
| Dynamic Range (-60 dB in ref to f_s A-Weighted) | | 90 | | dB |
| Signal-to-Noise Ratio | | 90 | | dB |
| Microphone/Line-In (Pin to ADC, Mic Boost = 0 dB) | | | | |
| Total Harmonic Distortion (THD + N) | | -78 | | dB |
| Dynamic Range (-60 dB in ref to f_s A-Weighted) | | 85 | | dB |
| Signal-to-Noise Ratio | | 85 | | dB |

GENERAL SPECIFICATIONS

| Parameter | Min | Typ | Max | Unit |
|---|-----------|-----------|-------------|----------|
| DIGITAL DECIMATION AND INTERPOLATION FILTERS— $f_s = 8$ kHz to 192 kHz ¹ | | | | |
| Pass Band | 0 | | 0.4 f_s | Hz |
| Pass-Band Ripple | | | ± 0.005 | dB |
| Stop Band | 0.6 f_s | | | Hz |
| Stop-Band Rejection | | | -100 | dB |
| Group Delay | | 20 | | 1/ f_s |
| Group Delay Variation over Pass Band | | 0 | | μ s |
| ANALOG-TO-DIGITAL CONVERTERS | | | | |
| Resolution | | 24 | | Bits |
| Gain Error (Full-Scale Span Relative to Nominal Input Voltage) | | | ± 10 | % |
| Interchannel Gain Mismatch (Difference of Gain Errors) | | ± 0.2 | ± 0.5 | dB |
| ADC Offset Error ¹ | | | ± 5 | mV |
| ADC Crosstalk ¹ | | | | |
| Line Inputs (Input L, Ground R, Read R; Input R, Ground L, Read L) | | -85 | | dB |
| Line_In to Other | | -100 | -80 | dB |

| Parameter | Min | Typ | Max | Unit |
|--|--|-------|-------|----------------|
| DIGITAL-TO-ANALOG CONVERTERS | | | | |
| Resolution | | 24 | | Bits |
| Gain Error (Full-Scale Span Relative to Nominal Input Voltage) ¹ | | | ±10 | % |
| Interchannel Gain Mismatch (Difference of Gain Errors) | | | ±0.5 | dB |
| Total Audible Out-of-Band Energy (Measured from 0.6 × f _s to 20 kHz) ¹ | | -85 | | dB |
| DAC Crosstalk (Input L, Zero R, Measure R_OUT; Input R, Zero L, Measure L_OUT) ¹ | | -95 | | dB |
| DAC VOLUMES | | | | |
| Step Size | | 1.5 | | dB |
| Output Gain/Attenuation Range | -58.5 | | 0 | dB |
| Mute Attenuation of 0 dB Fundamental ¹ | | -80 | | dB |
| ADC VOLUMES | | | | |
| Step Size | | 1.5 | | dB |
| PGA Gain/Attenuation Range | -58.5 | | +22.5 | dB |
| ANALOG MIXER | | | | |
| Signal-to-Noise Ratio Input to Output—Ports B, C, E, or F to Port D Output | | 90 | | dB |
| Step Size: All Mixer Inputs | | -1.5 | | dB |
| Input Gain/Attenuation Range: All Mixer Inputs | -34.5 | | +12.0 | dB |
| ANALOG LINE LEVEL OUTPUTS | | | | |
| Full-Scale Output Voltage | 1.0 2.83 | | | V rms V p-p |
| Ports A, D, E, F, and Mono Out | | | | |
| | Output Impedance ¹ | 190 | | Ω |
| | External Load Impedance ¹ | 10 | | kΩ |
| | Output Capacitance ¹ | 15 | | pF |
| | External Load Capacitance | | 1000 | pF |
| ANALOG HP DRIVE OUTPUTS | | | | |
| Full-Scale Output Voltage | 1.0 2.83 | | | V rms V p-p |
| Ports A and D | | | | |
| | Output Impedance ¹ | | 0.5 | Ω |
| | External Load Impedance ¹ | 32 | | Ω |
| | Output Capacitance ¹ | 15 | | pF |
| | External Load Capacitance ¹ | | 1000 | pF |
| ANALOG INPUTS | | | | |
| Input Voltages—Ports B, C, E, or F | | | | |
| | Mic Boost = 0 dB | 1 | | V rms |
| | | 2.83 | | V p-p |
| Input Voltages—Microphone Boost Amplifier, Ports B, C, or E | Mic Boost = 10 dB | 0.316 | | V rms |
| | | 0.894 | | V p-p |
| | Mic Boost = 20 dB | 0.1 | | V rms |
| | | 0.283 | | V p-p |
| | Mic Boost = 30 dB | 0.032 | | V rms |
| | | 0.089 | | V p-p |
| Input Impedance | | | | |
| PCBeep | | 23 | | kΩ |
| Ports B, C, E (Mic Boost = 0 dB) | | 150 | | kΩ |
| Port F | | 45 | | kΩ |
| Input Capacitance ¹ | | 5 | 7.5 | pF |

AD1884A

| Parameter | Min | Typ | Max | Unit |
|--|---------------------------------------|-----------------------|-----------------------|---------|
| MICROPHONE BIAS | | | | |
| MIC_BIAS-B, MIC_BIAS-C | | | | |
| MIC_BIAS_IN (Pin 33) = 5 V or 3.3 V | V_{REF} Setting = High-Z | High-Z | | |
| | V_{REF} Setting = 0 V | 0 | | V dc |
| | V_{REF} Setting = 50% | 1.65 | | V dc |
| MIC_BIAS_IN (Pin 33) = 5 V | V_{REF} Setting = 80% | 3.7 | | V dc |
| | V_{REF} Setting = 100% | 3.9 | | V dc |
| MIC_BIAS_IN (Pin 33) = 3.3 V | V_{REF} Setting = 80% | 2.86 | | V dc |
| | V_{REF} Setting = 100% | 3.0 | | V dc |
| MIC_BIAS-E (When Enabled as BIAS) | V_{REF} Setting = High-Z | High-Z | | |
| | V_{REF} Setting = 0 V | 0 | | V dc |
| | V_{REF} Setting = 50% | 1.65 | | V dc |
| | V_{REF} Setting = 80% | 2.86 | | V dc |
| | V_{REF} Setting = 100% | 3.0 | | V dc |
| Output Drive Current | V_{REF} Setting = 50%, 80%, or 100% | 1.6 | | mA |
| GPIO 0 | | | | |
| Input Signal High (V_{IH}) | | $DV_{IO} \times 0.60$ | DV_{IO} | V |
| Input Signal Low (V_{IL}) | | 0 | $DV_{IO} \times 0.24$ | V |
| Output Signal High (V_{OH}) | $I_{OUT} = -500 \mu A$ | $DV_{IO} \times 0.72$ | DV_{IO} | V |
| Output Signal Low (V_{OL}) | $I_{OUT} = +1500 \mu A$ | 0 | $DV_{IO} \times 0.10$ | V |
| Input Leakage Current (Signal High) (I_{IH}) | | 150 | | nA |
| Input Leakage Current (Signal Low) (I_{IL}) | | -50 | | μA |
| GPIO 1 and GPIO 2 | | | | |
| Input Signal High (V_{IH}) | | $AV_{DD} \times 0.60$ | AV_{DD} | V |
| Input Signal Low (V_{IL}) | | 0 | $AV_{DD} \times 0.24$ | V |
| Output Signal High (V_{OH}) | $I_{OUT} = -500 \mu A$ | $AV_{DD} \times 0.72$ | AV_{DD} | V |
| Output Signal Low (V_{OL}) | $I_{OUT} = +1500 \mu A$ | 0 | $AV_{DD} \times 0.10$ | V |
| Input Leakage Current (Signal High) (I_{IH}) | | 150 | | nA |
| Input Leakage Current (Signal Low) (I_{IL}) | | -50 | | μA |
| S/PDIF-Out | | | | |
| Input Signal High (V_{IH}) | | $DV_{IO} \times 0.60$ | DV_{IO} | V |
| Input Signal Low (V_{IL}) | | 0 | $DV_{IO} \times 0.24$ | V |
| Output Signal High (V_{OH}) | $I_{OUT} = -500 \mu A$ | $DV_{IO} \times 0.72$ | DV_{IO} | V |
| Output Signal Low (V_{OL}) | $I_{OUT} = +1500 \mu A$ | 0 | $DV_{IO} \times 0.10$ | V |
| Input Leakage Current (Signal High) (I_{IH}) | | 150 | | nA |
| Input Leakage Current (Signal Low) (I_{IL}) | | -50 | | μA |

www.DataSheet4U.com

| Parameter | Min | Typ | Max | Unit |
|---|-------|-------|-------|------|
| POWER SUPPLY | | | | |
| Analog (AV _{DD}) 3.3 V ± 5% | | | | |
| Power Supply Range | 3.13 | 3.30 | 3.46 | V |
| Power Dissipation | | 75.9 | | mW |
| Supply Current | | 23 | | mA |
| Digital (DV _{DD}) 3.3 V ± 10% | | | | |
| Power Supply Range | 2.97 | 3.30 | 3.63 | V |
| Power Dissipation | | 141.9 | | mW |
| Supply Current | | 43 | | mA |
| Digital (DV _{CORE}) 1.7 V Through 1.9 V ± 10% | | | | |
| Power Supply Range | 1.615 | 1.70 | 1.995 | V |
| Power Dissipation | | 61 | | mW |
| Supply Current | | 36 | | mA |
| Digital I/O (DV _{I/O}) 3.3 V ± 10% | | | | |
| Power Supply Range | 2.97 | 3.30 | 3.63 | V |
| Power Dissipation | | 3.3 | | mW |
| Supply Current | | 1 | | mA |
| Digital I/O (DV _{I/O}) 1.5 V ± 5.5% | | | | |
| Power Supply Range | 1.418 | 1.50 | 1.583 | V |
| Power Dissipation | | 0.08 | | mW |
| Supply Current | | 0.05 | | mA |
| Power Supply Rejection (Reference to f _s 100 mV p-p Signal @ 1 kHz) ¹ | | 80 | | dB |

¹ Guaranteed but not tested.

HD AUDIO LINK SPECIFICATION

High Definition Audio signals comply with the High Definition Audio Specification. Please refer to these specifications at: www.intel.com/standards/hdaudio.

POWER-DOWN STATES

| Parameter | ID _{VDD} Typ (1.7 V) | ID _{VDD} Typ (3.3 V) | IA _{VDD} Typ | Unit |
|---|-------------------------------|-------------------------------|-----------------------|------|
| Function Node in D0, All Nodes Active | 36 | 43 | 23 | mA |
| Function Node in D3 | 15.75 | 17 | 1 | mA |
| Function Node in D3 ¹ | 7.5 | 7.5 | 1 | mA |
| Codec in $\overline{\text{RESET}}$ | 3 | 3 | 3 | mA |
| Individual Block Power Savings | | | | |
| DAC Pair Powered Down Saves (Each) | 4.5 | 6 | 5 | mA |
| ADC Pair Powered Down Saves (Each) | 4.5 | 6 | 3 | mA |
| Mixer Power Control (and Associated Amps) Saves | 0 | 0 | 2 | mA |
| MIC_BIAS Powered Down Saves ² | 0 | 0 | 0.1 | mA |

¹ Maximum power saving mode; Register 0x31FD, Bit 4.

² Powering down the MIC_BIAS powers down all port MIC_BIAS pins. This disables all microphone bias circuits set to 100% or 50%, setting them to the high-Z state. The 0 V and high-Z states remain unaffected by the MIC_BIAS power state.

AD1884A

ABSOLUTE MAXIMUM RATINGS

Stresses greater than those listed below may cause permanent damage to the device. This is a stress rating only; functional operation of the device at these or any other conditions above those indicated in the operational section of this specification is not implied. Exposure to absolute maximum rating conditions for extended periods may affect device reliability.

| Parameter | Rating |
|-------------------------------------|------------------------------|
| Digital (DV_{DD}) | -0.30 V to +3.65 V |
| Digital (DV_{CORE}) | -0.30 V to +2.10 V |
| Digital I/O (DV_{IO}) | -0.30 V to +3.65 V |
| Analog (AV_{DD}) | -0.30 V to +3.65 V |
| Input Current (Except Supply Pins) | ± 10.0 mA |
| Analog Input Voltage (Signal Pins) | -0.30 V to $AV_{DD} + 0.3$ V |
| Digital Input Voltage (Signal Pins) | -0.30 V to $DV_{IO} + 0.3$ V |
| Ambient Temperature (Operating) | 0°C to +70°C |
| Storage Temperature | -65°C to +150°C |

ESD CAUTION



ESD (electrostatic discharge) sensitive device.

Charged devices and circuit boards can discharge without detection. Although this product features patented or proprietary protection circuitry, damage may occur on devices subjected to high energy ESD. Therefore, proper ESD precautions should be taken to avoid performance degradation or loss of functionality.

ENVIRONMENTAL CONDITIONS

Ambient Temperature Rating:

$$T_{AMB} = T_{CASE} - (PD \times \theta_{CA})$$

T_{CASE} = case temperature in °C

PD = power dissipation in W

θ_{CA} = thermal resistance (case-to-ambient)

θ_{JA} = thermal resistance (junction-to-ambient)

θ_{JC} = thermal resistance (junction-to-case)

All measurements per EIA-JESD51 with 2S2P test board per EIA-JESD51-7.

| Package | θ_{JA} | θ_{JC} | θ_{CA} | Unit |
|----------|---------------|---------------|---------------|------|
| LFCSV_VQ | 47 | 15 | 32 | °C/W |

PIN CONFIGURATION AND FUNCTION DESCRIPTIONS

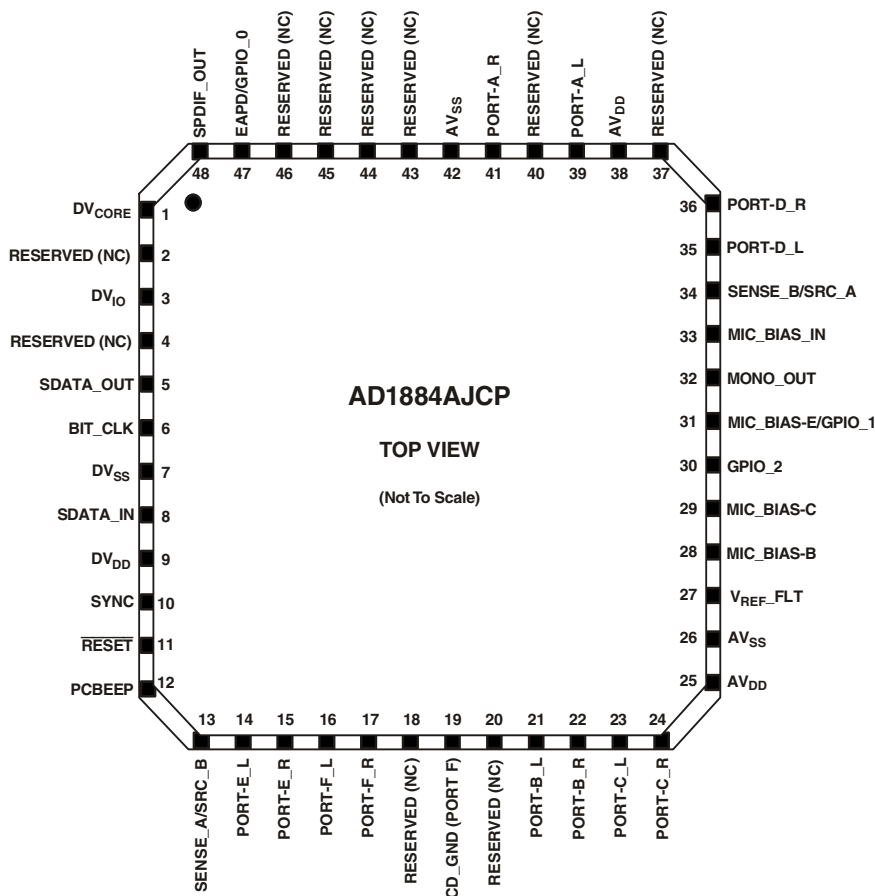

Figure 2. AD1884A 48-Lead Package and Pinout

AD1884A

Table 4. Pin Function Descriptions

| Mnemonic | Pin No. | I/O | Description |
|-------------------------------|---------|-------------|--|
| DIGITAL INTERFACE | | | |
| SDATA_OUT | 5 | I | Link Serial Data Output. AD1884A input stream. Clocked on both edges of the BIT_CLK. |
| BIT_CLK | 6 | I | Link Bit Clock. 24.000 MHz serial data clock. |
| SDATA_IN | 8 | I/O | Link Serial Data Input. AD1884A output stream clocked only on one edge of BIT_CLK. |
| SYNC | 10 | I | Link Frame Sync. |
| RESET | 11 | I | Link Reset. AD1884A master hardware reset. |
| DIGITAL I/O and EAPD | | | |
| GPIO_2 | 30 | I/O | General-Purpose Input/Output Pin. Digital signal used to control or sense external circuitry. |
| MIC_BIAS-E/GPIO_1 | 31 | I/O | Microphone Bias for Port E/General-Purpose Input/Output. Capable of high-Z, 1.65 V, and 2.86 V. Pin 31 shares functionality between MIC_BIAS-E (default) and GPIO_1. These functions are mutually exclusive and the MIC_BIAS function takes priority over the GPIO function. |
| EAPD/GPIO_0 | 47 | I/O | EAPD/General-Purpose Input/Output Pin. Pin 47 shares functionality between GPIO_0 and EAPD. These functions are mutually exclusive and the EAPD function takes priority over the GPIO function. By default, the pin is in a high-Z state. External resistors should be used to ensure the proper circuit state when this pin is in high-Z. |
| S/PDIF_OUT | 48 | O | Supports S/PDIF Output. |
| JACK SENSE | | | |
| SENSE_A/SRC_B | 13 | I/O | Jack Sense A-D Input/Sense B Drive. |
| SENSE_B/SRC_A | 34 | I/O | Jack Sense E-F Input/Sense A Drive. |
| ANALOG I/O | | | |
| PCBEEP | 12 | LI | Monaural Input from System for Analog PCBeep. |
| PORT-E_L | 14 | LI, MIC, LO | Auxiliary Input/Output Left Channel. |
| PORT-E_R | 15 | LI, MIC, LO | Auxiliary Input/Output Right Channel. |
| PORT-F_L | 16 | LI, LO | Auxiliary Input/Output Left Channel. |
| PORT-F_R | 17 | LI, LO | Auxiliary Input/Output Right Channel. |
| CD_GND (PORT-F) | 19 | I | CD Audio Analog Ground Reference. Must be connected to AGND via a 0.1 μ F capacitor if not in use as CD_GND. MUST always be ac-coupled. |
| PORT-B_L | 21 | LI, MIC | Front Panel Stereo MIC/Line-In. |
| PORT-B_R | 22 | LI, MIC | Front Panel Stereo MIC/Line-In. |
| PORT-C_L | 23 | LI, MIC | Rear Panel Stereo MIC/Line-In. |
| PORT-C_R | 24 | LI, MIC | Rear Panel Stereo MIC/Line-In. |
| MONO_OUT | 32 | LO | Monaural Output to Internal Speaker or Telephony Subsystem Speakerphone. |
| PORT-D_L | 35 | HP, LO | Rear Panel Headphone/Line-Out. |
| PORT-D_R | 36 | HP, LO | Rear Panel Headphone/Line-Out. |
| PORT-A_L | 39 | HP, LO | Front Panel Headphone/Line-Out. |
| PORT-A_R | 41 | HP, LO | Front Panel Headphone/Line-Out. |
| FILTER/MIC_BIAS | | | |
| V _{REF_FLT} | 27 | O | Voltage Reference Filter. |
| MIC_BIAS-B | 28 | O | Switchable Microphone Bias. For use with Port B (Pins 21, 22). |
| MIC_BIAS-C | 29 | O | Switchable Microphone Bias. For use with Port C (Pins 23, 24). Both MIC bias pins are capable of: High-Z, 0 V, 1.65 V, 3.7 V, and 3.9 V (with 5.0 V on Pin 33) High-Z, 0 V, 1.65 V, 2.86 V, and 3.0 V (with 3.3 V on Pin 33). |
| MIC_BIAS_IN 5.0 V or 3.3 V | 33 | I | Source Power for Microphone Bias Boost Circuitry. Connect this pin to 5.0 V via a low-pass filter. When connected this way, the AD1884A is capable of providing 3.9 V as a mic bias to all of the mic bias pins (except on Pin 31). If 5 V is not available, connect this pin to 3.3 V (AV _{DD}) via a low-pass filter. |

The symbols used in this table are defined as: I = input, O = output, LI = line level input, LO = line level output, HP = output capable of driving headphone load, MIC = input supports microphones with MIC bias and boost amplifier.

Table 4. Pin Function Descriptions (Continued)

| Mnemonic | Pin No. | I/O | Description |
|--|---------|-----|---|
| POWER AND GROUND DV _{CORE} 1.7 V to 1.9 V or FILTER | 1 | I/O | CAUTION: DO NOT APPLY 3.3 V TO THIS PIN! Filter connection for internal core voltage regulator. If Pin 9 is connected to 3.3 V DV _{DD} , this pin must be connected to filter caps: 10 μ F, 1.0 μ F, and 0.1 μ F connected in parallel between Pin 1 and DV _{SS} (Pin 7). Direct, filtered 1.7 V to 1.9 V DV _{DD} can be applied to Pin 1 to lower the digital power requirements. Pin 9 MUST be connected to Pin 1 in this case. |
| DV _{IO} 1.5 V or 3.3 V | 3 | I | Link Digital I/O Voltage Reference. 3.3 V \pm 10% or 1.5 V \pm 5.5% |
| DV _{SS} | 7 | I | Digital Supply Return (Ground). |
| DV _{DD} 1.7 V to 1.9 V or 3.3 V | 9 | I | Digital Supply Voltage 3.3 V \pm 10%. This is regulated down to DV _{CORE} on Pin 1 to supply the internal digital core internal to the AD1884A. Direct, filtered 1.7 V to 1.9 V DV _{DD} can be applied to Pin 1 to lower the digital power requirements. Pin 9 MUST be connected to Pin 1 in this case. |
| AV _{DD} 3.3 V | 25, 38 | I | CAUTION: DO NOT APPLY 5 V TO THESE PINS! Analog Supply Voltage 3.3 V \pm 5%. Note: AV _{DD} supplies should be well regulated and filtered as supply noise degrades audio performance. |
| AV _{SS} | 26, 42 | I | Analog Supply Return (Ground). AV _{SS} should be connected to DV _{SS} using a conductive trace under, or close to, the AD1884A. |

The symbols used in this table are defined as: I = input, O = output, LI = line level input, LO = line level output, HP = output capable of driving headphone load, MIC = input supports microphones with MIC bias and boost amplifier.

AD1884A

HD AUDIO WIDGETS

Table 5. HD Audio Widgets¹

| Node ID | Name | Type ID | Type | Description |
|---------|-----------------------------|---------|----------------|--|
| 0x00 | ROOT | x | Root | Device identification |
| 0x01 | FUNCTION | x | Function | Designates this device as an audio codec |
| 0x02 | S/PDIF DAC | 0 | Audio Output | S/PDIF digital stream output interface |
| 0x03 | DAC_0 | 0 | Audio Output | Stereo headphone channel digital/audio converter |
| 0x04 | DAC_1 | 0 | Audio Output | Stereo front channel digital/audio converter |
| 0x07 | Port A Mixer | 2 | Audio Mixer | Mixes the DAC_(0, 1) and analog mixer output to drive Port A |
| 0x08 | ADC_0 | 1 | Audio Input | Stereo record Channel 0 audio/digital converters |
| 0x09 | ADC_1 | 1 | Audio Input | Stereo record Channel 1 audio/digital converters |
| 0x0A | Port D Mixer | 2 | Audio Mixer | Mixes the DAC_1 and analog mixer output to drive Port D |
| 0x0B | Port F Mixer | 2 | Audio Mixer | Mixes the DAC_(0, 1) and analog mixer output to drive Port F |
| 0x0C | ADC Selector 0 | 3 | Audio Selector | Selects and amplifies/attenuates the input to ADC_0 |
| 0x0D | ADC Selector 1 | 3 | Audio Selector | Selects and amplifies/attenuates the input to ADC_1 |
| 0x0E | Mono Out Selector | 3 | Audio Selector | Selects the mono out DAC_(0, 1) |
| 0x0F | Port F Out Selector | 3 | Audio Selector | Selects the Port F DAC_(0, 1) |
| 0x10 | Digital BEEP | 7 | BEEP Generator | Internal digital PCBEEP signal |
| 0x11 | Port A (Headphone) | 4 | Pin Complex | Headphone jack pins |
| 0x12 | Port D (Line Out) | 4 | Pin Complex | Line out jack pins |
| 0x13 | Mono Out | 4 | Pin Complex | Monaural output pin (internal speakers or telephony system) |
| 0x14 | Port B (Mic In) | 4 | Pin Complex | Microphone in jack pins |
| 0x15 | Port C (Line In) | 4 | Pin Complex | Line in jack pins |
| 0x16 | Port F (Aux In/Out) | 4 | Pin Complex | Auxiliary I/O pins |
| 0x19 | Mixer Power Down | 5 | Power Widget | Powers down the analog mixer and associated amps |
| 0x1A | Analog PCBEEP | 4 | Pin Complex | External analog PCBEEP signal input |
| 0x1B | S/PDIF_Out | 4 | Pin Complex | S/PDIF output pin |
| 0x1C | Port E (Dock I/O) | 4 | Pin Complex | Analog dock I/O pins |
| 0x1D | V _{REF} Power Down | F | Vendor Defined | Powers down the V _{REF} circuitry |
| 0x1E | Mono Out Mixer | 2 | Audio Mixer | Mixes the DAC_(0, 1) and analog mixer output to drive mono out |
| 0x1F | Stereo Mix-Down | 2 | Audio Mixer | Mixes the stereo L/R channels to drive mono output |
| 0x20 | Analog Mixer | 2 | Audio Mixer | Mixes individually gainable analog inputs |
| 0x21 | Mixer Output Atten | 3 | Audio Selector | Attenuates the analog mixer output to drive the port mixers |
| 0x22 | Port A Out Selector | 3 | Audio Selector | Selects the Port A DAC_(0, 1) |
| 0x23 | Port E Out Selector | 3 | Audio Selector | Selects the Port E DAC_(0, 1) |
| 0x24 | Port E Mixer | 2 | Audio Mixer | Mixes the DAC_(0, 1) and analog mixer output to drive Port E |
| 0x25 | Port E Mic Boost | 3 | Audio Selector | 0 dB, 10 dB, 20 dB, or 30 dB gain boost for Port E |
| 0x26 | BIAS Power Down | F | Vendor Defined | Powers down the internal MIC_BIAS_FILTER and all MIC_BIAS pins |

¹ All node IDs (NIDs) are sequential in the codec. Any NIDs missing from this table are vendor defined.

HD AUDIO PARAMETERS

Table 6. Root and Function Node Parameters

| Node ID | Name | Vendor ID 00 | Revision ID 01 ¹ | Sub Node Count 04 | Func. Group Type 05 | Audio F.G. Caps 08 | GPIO Caps 11 |
|---------|----------|-----------------|--------------------------------|----------------------|------------------------|-----------------------|-----------------|
| 0x00 | ROOT | 0x11D4 184A | 0x0010 0100 | 0x0001 0001 | | | |
| 0x01 | FUNCTION | | | 0x0002 0029 | 0x0000 0001 | 0x0001 0C0C | 0x4000 0003 |

¹ Subject to change with silicon stepping.

Table 7. Subsystem ID

| Node ID | Name | Type | Value | 31:16 SSID | 15:8 SKU | 7:0 ASM ID |
|---------|----------|----------|-------------|---------------|-------------|---------------|
| 0x01 | FUNCTION | Function | 0xBFD4 0000 | 0xBFD4 | 0x00 | 0x00 |

AD1884A

WIDGET PARAMETERS

Table 8. Widget Parameters

| Node ID | Widget Capabilities 0x09 | PCM Size, Rate 0x0A | Stream Formats 0x0B | Pin Capabilities 0x0C | Input Amp Capabilities 0x0D | Con. List Length 0x0E | Power States 0x0F | Output Amp Capabilities 0x12 |
|---------|--------------------------|---------------------|---------------------|-----------------------|-----------------------------|-----------------------|-------------------|------------------------------|
| 0x01 | 0x0000 04C0 | 0x000E 07FF | 0x0000 0001 | | 0x8000 0000 | | 0x0000 0009 | 0x0005 2727 |
| 0x02 | 0x0003 0211 | 0x000E 07E0 | 0x0000 0005 | | | 0x0000 0000 | | |
| 0x03 | 0x0000 0405 | 0x000E 07FF | 0x0000 0001 | | | 0x0000 0000 | 0x0000 0009 | 0x0005 2727 |
| 0x04 | 0x0000 0405 | 0x000E 07FF | 0x0000 0001 | | | 0x0000 0000 | 0x0000 0009 | 0x0005 2727 |
| 0x07 | 0x0020 0103 | | | | 0x8000 0000 | 0x0000 0002 | | |
| 0x08 | 0x0010 0501 | 0x000E 07FF | 0x0000 0001 | | | 0x0000 0001 | 0x0000 0009 | |
| 0x09 | 0x0010 0501 | 0x000E 07FF | 0x0000 0001 | | | 0x0000 0001 | 0x0000 0009 | |
| 0x0A | 0x0020 0103 | | | | 0x8000 0000 | 0x0000 0002 | | |
| 0x0B | 0x0020 0103 | | | | 0x8000 0000 | 0x0000 0002 | | |
| 0x0C | 0x0030 010D | | | | | 0x0000 0006 | | 0x8005 3627 |
| 0x0D | 0x0030 010D | | | | | 0x0000 0006 | | 0x8005 3627 |
| 0x0E | 0x0030 0101 | | | | | 0x0000 0002 | | |
| 0x0F | 0x0030 0101 | | | | | 0x0000 0002 | | |
| 0x10 | 0x0070 000C | | | | | 0x0000 0000 | | 0x800B 0F0F |
| 0x11 | 0x0040 018D | | | 0x0000 001F | | 0x0000 0001 | | 0x8000 0000 |
| 0x12 | 0x0040 058D | | | 0x0001 001F | | 0x0000 0001 | 0x0000 0009 | 0x8000 0000 |
| 0x13 | 0x0040 050C | | | 0x0001 0010 | | 0x0000 0001 | 0x0000 0009 | 0x8005 1F1F |
| 0x14 | 0x0040 008B | | | 0x0000 3727 | 0x0027 0300 | 0x0000 0000 | | |
| 0x15 | 0x0040 008B | | | 0x0000 3727 | 0x0027 0300 | 0x0000 0000 | | |
| 0x16 | 0x0040 058D | | | 0x0001 0037 | | 0x0000 0001 | 0x0000 0009 | 0x8000 0000 |
| 0x19 | 0x0050 0500 | | | | | 0x0000 0002 | 0x0000 0009 | |
| 0x1A | 0x0040 0000 | | | 0x0000 0020 | | 0x0000 0000 | | |
| 0x1B | 0x0040 038D | | | 0x0000 0014 | | 0x0000 0001 | | 0x8005 2727 |
| 0x1C | 0x0040 018D | | | 0x0000 3737 | | 0x0000 0001 | | 0x8000 0000 |
| 0x1D | 0x00F0 0100 | | | | | 0x0000 000A | | |
| 0x1E | 0x0020 0103 | | | | 0x8000 0000 | 0x0000 0002 | | |
| 0x1F | 0x0020 0100 | | | | | 0x0000 0001 | | |
| 0x20 | 0x0020 010B | | | | 0x8005 1F17 | 0x0000 0007 | | |
| 0x21 | 0x0030 010D | | | | | 0x0000 0001 | | 0x8005 1F1F |
| 0x22 | 0x0030 0101 | | | | | 0x0000 0002 | | |
| 0x23 | 0x0030 0101 | | | | | 0x0000 0002 | | |
| 0x24 | 0x0020 0103 | | | | 0x8000 0000 | 0x0000 0002 | | |
| 0x25 | 0x0030 010D | | | | | 0x0000 0001 | | 0x0027 0300 |
| 0x26 | 0x00F0 0100 | | | | | 0x0000 0003 | | |

CONNECTION LIST

Table 9. Connection List

| Node ID | Connections | | | 0 | | 1 | | 2 | | 3 | | 4 | | 5 | | 6 | | 7 | | 8 | | 9 | |
|---------|-------------|-------------|-------------|------|----------------|------|------|------|---|------|------|------|------|------|---|------|---|-----|---|-----|---|-----|--|
| | [0-3] | [4-7] | [8-11] | NID | R ¹ | NID | R | NID | R | NID | R | NID | R | NID | R | NID | R | NID | R | NID | R | NID | |
| 0x02 | | | | | | | | | | | | | | | | | | | | | | | |
| 0x03 | | | | | | | | | | | | | | | | | | | | | | | |
| 0x04 | | | | | | | | | | | | | | | | | | | | | | | |
| 0x07 | 0x0000 2122 | | | 0x22 | | 0x21 | | | | | | | | | | | | | | | | | |
| 0x08 | 0x0000 000C | | | 0x0C | | | | | | | | | | | | | | | | | | | |
| 0x09 | 0x0000 000D | | | 0x0D | | | | | | | | | | | | | | | | | | | |
| 0x0A | 0x0000 2104 | | | 0x04 | | 0x21 | | | | | | | | | | | | | | | | | |
| 0x0B | 0x0000 210F | | | 0x0F | | 0x21 | | | | | | | | | | | | | | | | | |
| 0x0C | 0x2016 1514 | 0x0000 0025 | | 0x14 | | 0x15 | | 0x16 | | 0x20 | | 0x25 | | | | | | | | | | | |
| 0x0D | 0x2016 1514 | 0x0000 0025 | | 0x14 | | 0x15 | | 0x16 | | 0x20 | | 0x25 | | | | | | | | | | | |
| 0x0E | 0x0000 0403 | | | 0x03 | | 0x04 | | | | | | | | | | | | | | | | | |
| 0x0F | 0x0000 0403 | | | 0x03 | | 0x04 | | | | | | | | | | | | | | | | | |
| 0x10 | | | | | | | | | | | | | | | | | | | | | | | |
| 0x11 | 0x0000 0007 | | | 0x07 | | | | | | | | | | | | | | | | | | | |
| 0x12 | 0x0000 000A | | | 0x0A | | | | | | | | | | | | | | | | | | | |
| 0x13 | 0x0000 001F | | | 0x1F | | | | | | | | | | | | | | | | | | | |
| 0x14 | | | | | | | | | | | | | | | | | | | | | | | |
| 0x15 | | | | | | | | | | | | | | | | | | | | | | | |
| 0x16 | 0x0000 000B | | | 0x0B | | | | | | | | | | | | | | | | | | | |
| 0x19 | 0x0000 2120 | | | 0x20 | | 0x21 | | | | | | | | | | | | | | | | | |
| 0x1A | | | | | | | | | | | | | | | | | | | | | | | |
| 0x1B | 0x0000 0002 | | | 0x02 | | | | | | | | | | | | | | | | | | | |
| 0x1C | 0x0000 0024 | | | 0x24 | | | | | | | | | | | | | | | | | | | |
| 0x1D | 0x118F 0A07 | 0x1C1A 1996 | 0x0000 A61E | 0x07 | 0x0A | 1 | 0x0F | 0x11 | 1 | 0x16 | 0x19 | 0x1A | 0x1C | 0x1E | 1 | 0x26 | | | | | | | |
| 0x1E | 0x0000 210E | | | 0x0E | | 0x21 | | | | | | | | | | | | | | | | | |
| 0x1F | 0x0000 001E | | | 0x1E | | | | | | | | | | | | | | | | | | | |
| 0x20 | 0x1A16 1514 | 0x004 0325 | | 0x14 | | 0x15 | | 0x16 | | 0x1A | | 0x25 | | 0x03 | | 0x04 | | | | | | | |
| 0x21 | 0x0000 0020 | | | 0x20 | | | | | | | | | | | | | | | | | | | |
| 0x22 | 0x0000 0403 | | | 0x03 | | 0x04 | | | | | | | | | | | | | | | | | |
| 0x23 | 0x0000 0403 | | | 0x03 | | 0x04 | | | | | | | | | | | | | | | | | |
| 0x24 | 0x0000 2123 | | | 0x23 | | 0x21 | | | | | | | | | | | | | | | | | |
| 0x25 | 0x0000 001C | | | 0x1C | | | | | | | | | | | | | | | | | | | |
| 0x26 | 0x001C 1514 | | | 0x14 | | 0x15 | | 0x1C | | | | | | | | | | | | | | | |

¹R = the MS bit of any node ID indicates a 2-tuple NID pair delineating a continuous range of nodes. If the MS bit is set (=1), that list entry forms a range of entries from the previous NID to the current NID. For additional information, see chapter 7.1.2, "Node Addressing" in the *High Definition Audio Specification*.

AD1884A

DEFAULT CONFIGURATION BYTES

Table 10. Default Configuration Bytes

| Node ID | Name | Value | 31:30 | 29:28 | 27:24 | 23:20 |
|---------|---------------------|-------------|--------------|----------|-----------|-------------|
| | | | Connectivity | Location | | Def. Device |
| | | | | Chassis | Position | |
| 0x11 | Port A (Headphone) | 0x0321 40F0 | Jack | External | Left | HP Out |
| 0x12 | Port D (Line Out) | 0x2121 4010 | Jack | Separate | Rear | HP Out |
| 0x13 | Mono Out | 0x9017 01F0 | Fixed | Internal | N/A | Speaker |
| 0x14 | Port B (Mic In) | 0x03A1 90F0 | Jack | External | Left | Mic In |
| 0x15 | Port C (Line In) | 0xB7A7 0121 | Fixed | Other | Special 1 | Mic In |
| 0x16 | Port F (Aux In/Out) | 0x9933 012E | Fixed | Internal | Special 3 | CD |
| 0x1A | Analog PCBeep | 0x90F3 01F0 | Fixed | Internal | N/A | other |
| 0x1B | S/PDIF Out | 0x0145 10F0 | Jack | External | Rear | SPDIF Out |
| 0x1C | Port E (Dock I/O) | 0x21A1 9020 | Jack | Separate | Rear | Mic In |

Table 10. Default Configuration Bytes (Continued)

| Node ID | Name | Value | 19:16 | 15:12 | 8 | 7:4 | 3:0 |
|---------|---------------------|-------------|--------------|---------|---------|------------|------|
| | | | Conn Type | Color | JD OVRD | Def. Assn. | Seq. |
| 0x11 | Port A (Headphone) | 0x0321 40F0 | 1/8" Jack | Green | 0 | 0xF | 0x0 |
| 0x12 | Port D (Line Out) | 0x2121 4010 | 1/8" Jack | Green | 0 | 0x1 | 0x0 |
| 0x13 | Mono Out | 0x9017 01F0 | Other Analog | Unknown | 1 | 0xF | 0x0 |
| 0x14 | Port B (Mic In) | 0x03A1 90F0 | 1/8" Jack | Pink | 0 | 0xF | 0x0 |
| 0x15 | Port C (Line In) | 0xB7A7 0121 | Other Analog | Unknown | 1 | 0x2 | 0x1 |
| 0x16 | Port F (Aux In/Out) | 0x9933 012E | ATAPI | Unknown | 1 | 0x2 | 0xE |
| 0x1A | Analog PCBeep | 0x90F3 01F0 | ATAPI | Unknown | 1 | 0xF | 0x0 |
| 0x1B | S/PDIF Out | 0x0145 10F0 | Optical | Black | 0 | 0xF | 0x0 |
| 0x1C | Port E (Dock I/O) | 0x21A1 9020 | 1/8" Jack | Pink | 0 | 0x2 | 0x0 |

OUTLINE DIMENSIONS

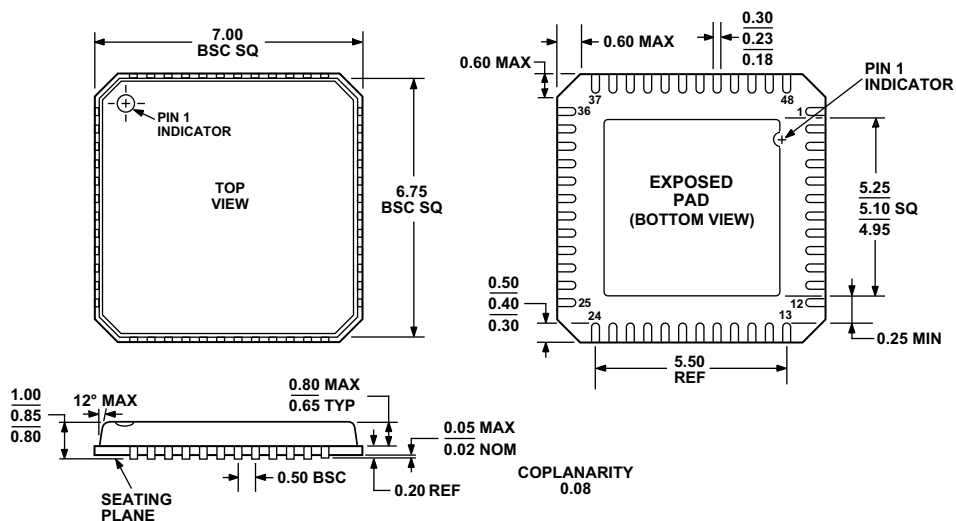

COMPLIANT TO JEDEC STANDARDS MO-220-VKGD-2

Figure 3. 48-Lead Lead Frame Chip Scale Package [LFCSP_VQ]
 7 mm x 7 mm Body, Very Thin Quad
 (CP-48-1)
 Dimensions shown in millimeters

ORDERING GUIDE

| Model | Temperature Range | Package Description | Package Option |
|-----------------------------|-------------------|-------------------------------------|----------------|
| AD1884AJCPZ ¹ | 0°C to 70°C | 48-Lead LFCSP_VQ | CP-48-1 |
| AD1884AJCPZ-RL ¹ | 0°C to 70°C | 48-Lead LFCSP_VQ, 13" Tape and Reel | CP-48-1 |

¹Z = RoHS Compliant Part.

AD1884A

AD1884A

www.DataSheet4U.com

©2008 Analog Devices, Inc. All rights reserved. Trademarks and registered trademarks are the property of their respective owners.
D07398-0-3/08(0)



www.analog.com